

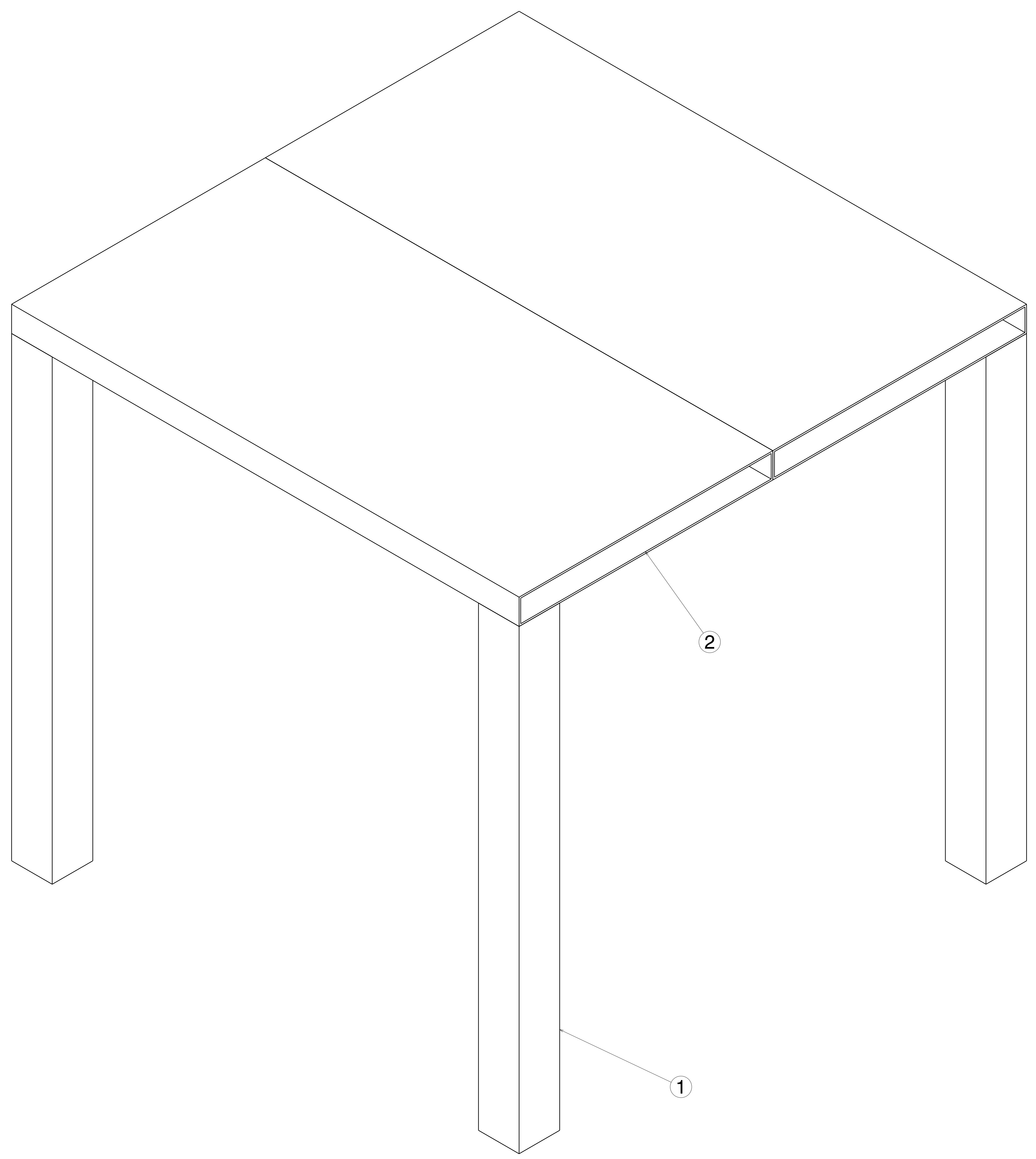

REV	DATE	DESCRIPTION
00	28JUL2020	INITIAL REVISION

- NOTES:
- (⊥) ALL VERTICAL SUPPORTS ARE PERPENDICULAR.
 - FLATNESS OF .5MM IS APPLIED BY DEFAULT.
 - ⊲ WELD BEAD OF 2MM RADIUS IS FOLLOWED.
 - ▽▽ SURFACE FINISH MEDIUM TO SMOOTH IS USED.
 - ALL TUBES ARE AS PER APL APOLLO STANDARD. CHANGES MAY EFFECT THE LOAD CAPACITY.
 - ALL HORIZONTAL AND VERTICAL TUBES ARE PERPENDICULAR TO EACH OTHER WITH ±1 DEG.
 - FINE WELDING IS REQUIRED AS PER MENTIONED DETAILS AND FINISHING.
 - HIGHER CURRENT WELDING MAY AFFECT THE BRITTLENESS OF MATERIAL WHICH LATER MAY RAISE TO WEAKENING OF STRUCTURE.
 - FABRICATORS ARE ALLOWED TO USE FITTINGS/FRAMES/SUPPORTS AS NEEDED AND THE SAME MUST BE COMMUNICATED BACK TO ENGINEERING TEAM.
 - BOP COMPONENT WEIGHTS ARE FOR REFERENCE ONLY AND SUBJECTED TO CHANGE PER PURCHASED COMPONENTS.



Isometric view
Scale: 3:4

2	Table top Plank	250 X 25 X 1.6 X 500	2	3.42
1	Table top Frame 1	40 X 40 X 2.6 X 450	4	1.38
ITEM NO.	PART NUMBER	DESCRIPTION	QTY.	Wt (Kg)/Each
This drawing is our property. It can't be reproduced or communicated without our written agreement.		APL APOLLO TUBES LTD. 		
DRAWN BY		DATE	DRAWING TITLE	
SB		28JUL2020	TABLE TOP	
CHECKED BY		DATE	SIZE	DRAWING NUMBER
P2P Analysis & Solutions		28JUL2020	A0	P2P TABLE TOP
DESIGNED BY		DATE	SCALE	WEIGHT (kg)
P2P Analysis & Solutions		28JUL2020	As Indicated	0kg
				SHEET 1 OF 3

UNLESS OTHERWISE SPECIFIED DIMENSION ARE IN MM
VIEWS: THIRD ANGLE PROJECTION

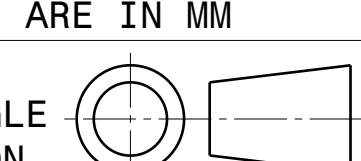

REV	DATE	DESCRIPTION
00	28JUL2020	INITIAL REVISION

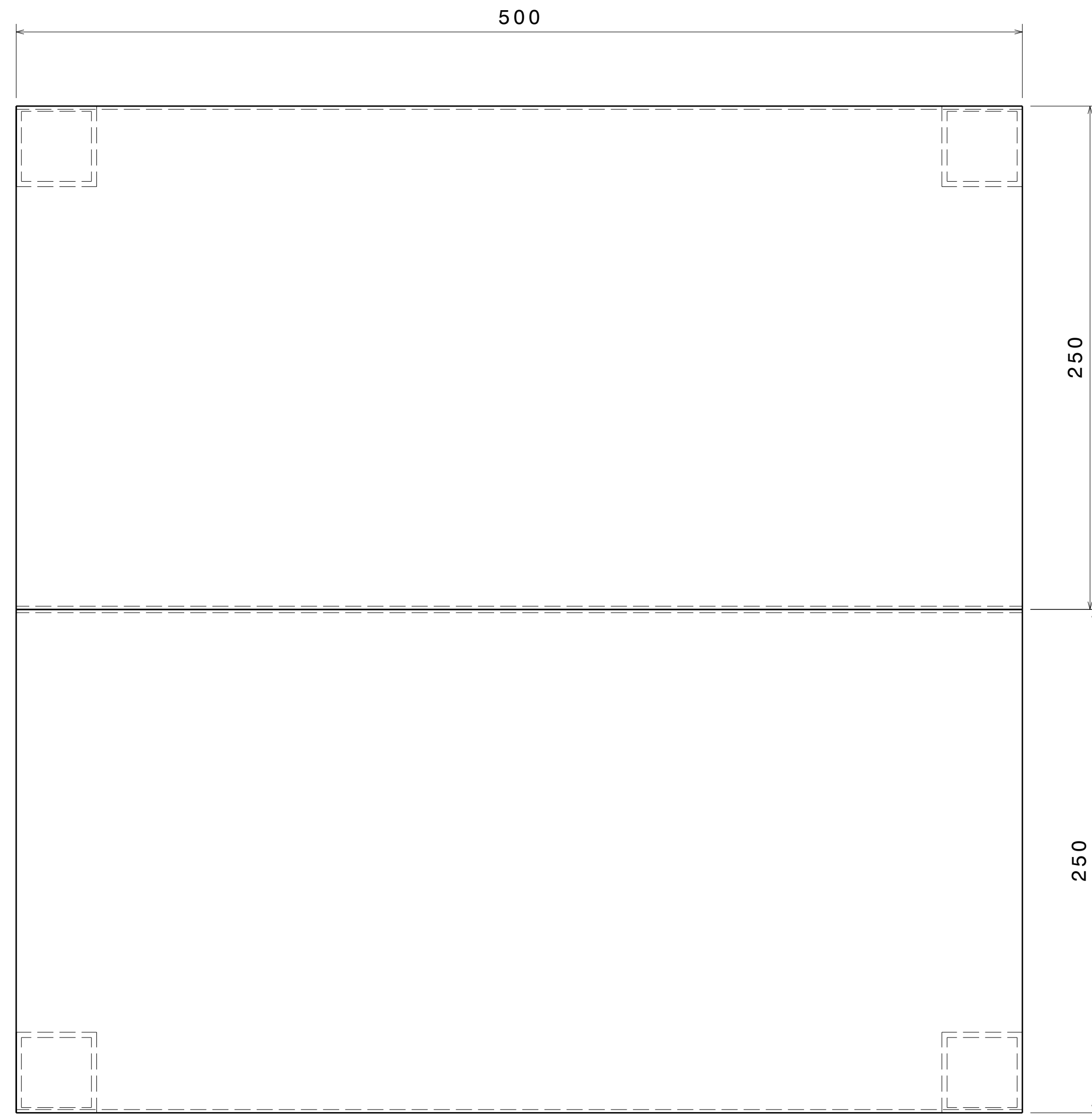

Top view
Scale: 1:2

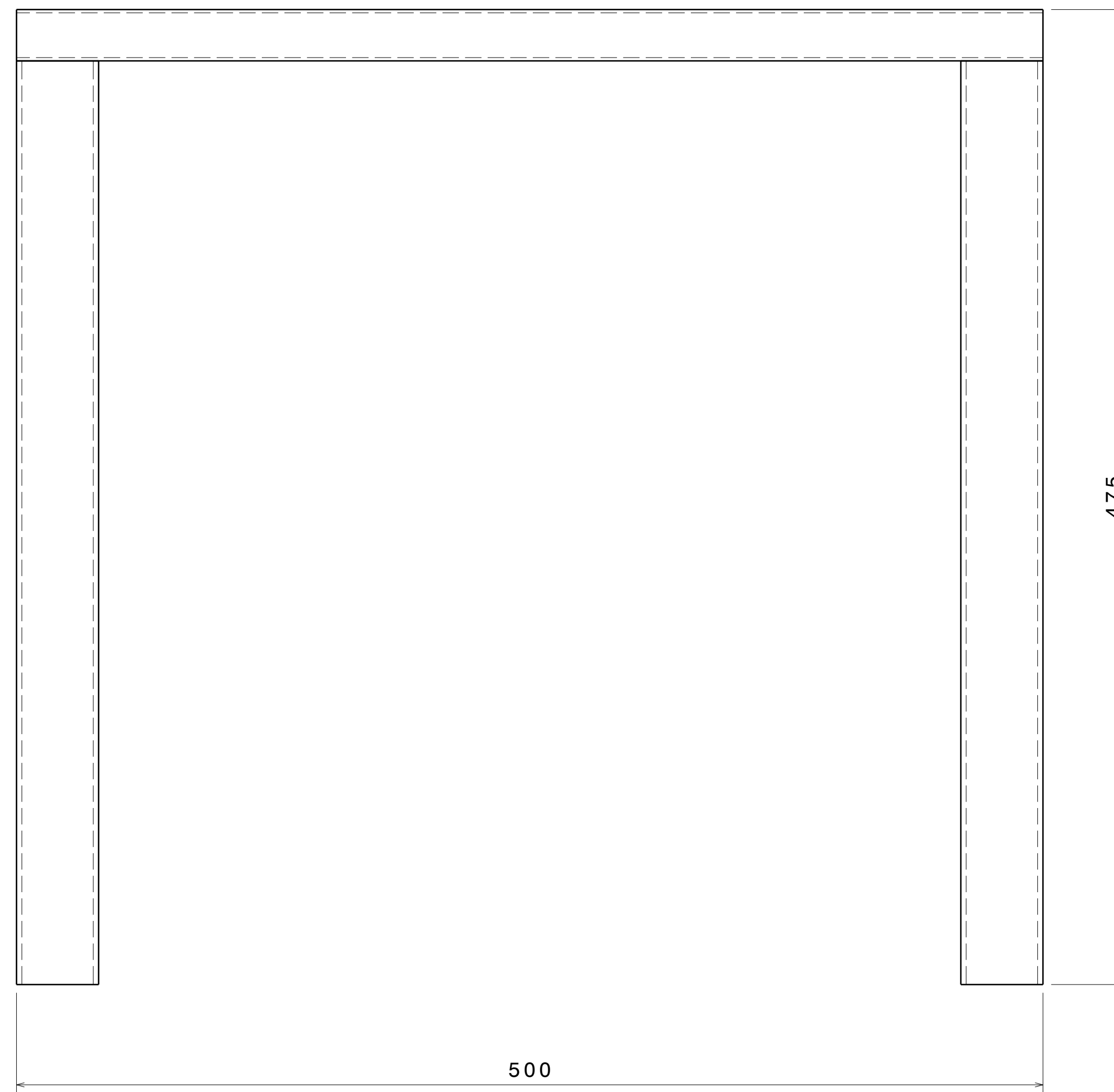

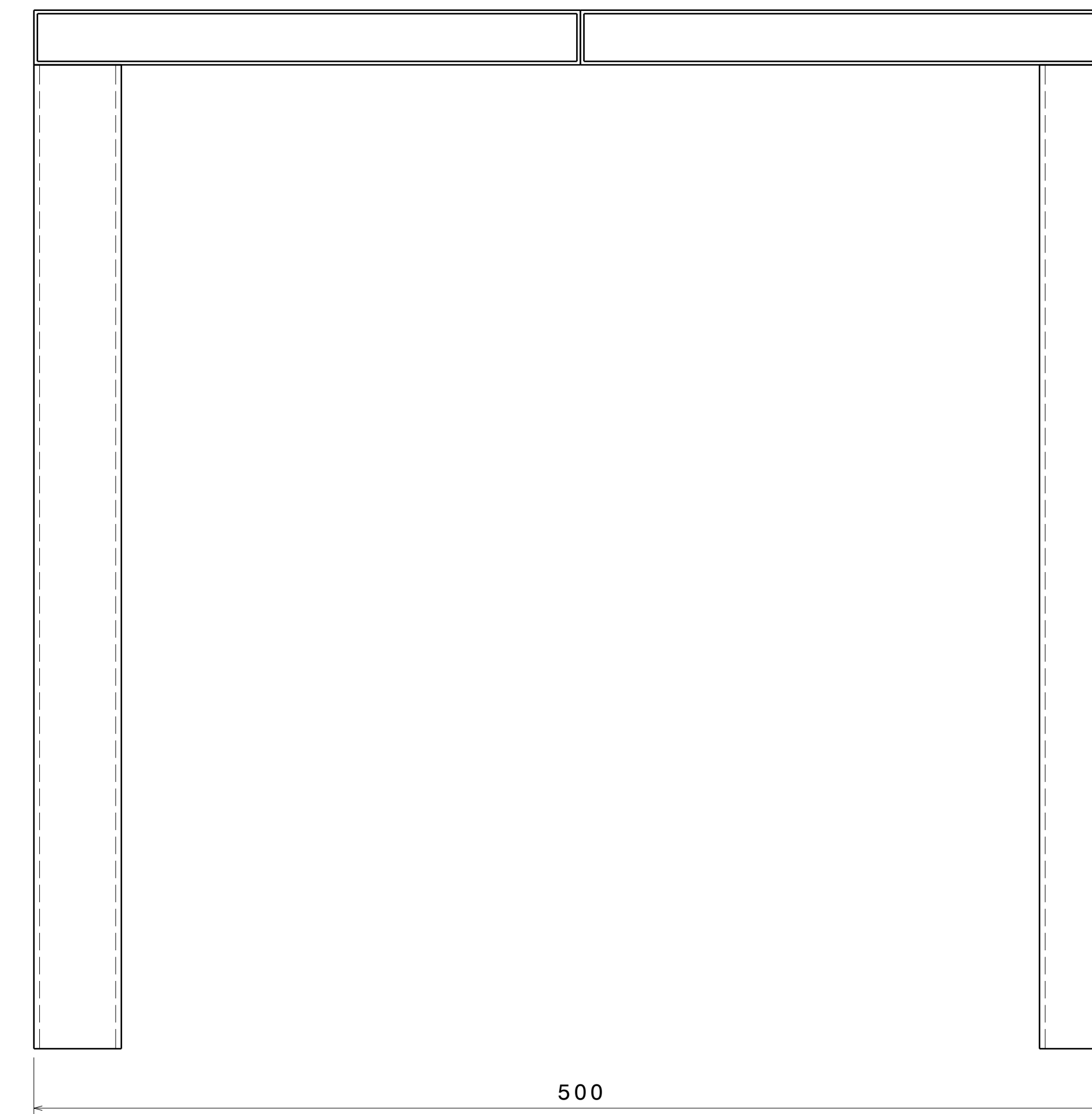

Front view
Scale: 1:2

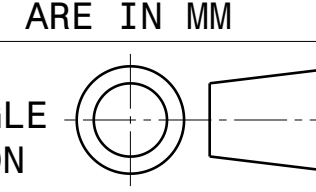

Right view
Scale: 1:2

UNLESS OTHERWISE SPECIFIED DIMENSION ARE IN MM
VIEWS: THIRD ANGLE PROJECTION



This drawing is our property. It can't be reproduced or communicated without our written agreement.		APL APOLLO TUBES LTD. 	
DRAWN BY SB		DATE 28JUL2020	
CHECKED BY P2P Analysis & Solutions		DATE 28JUL2020	
DESIGNED BY P2P Analysis & Solutions		DATE 28JUL2020	
SIZE A0	DRAWING NUMBER P2P TABLE TOP		REV 00
SCALE NONE	WEIGHT (kg)	XXX	SHEET 2 OF 3

REV	DATE	DESCRIPTION
00	28JUL2020	INITIAL REVISION

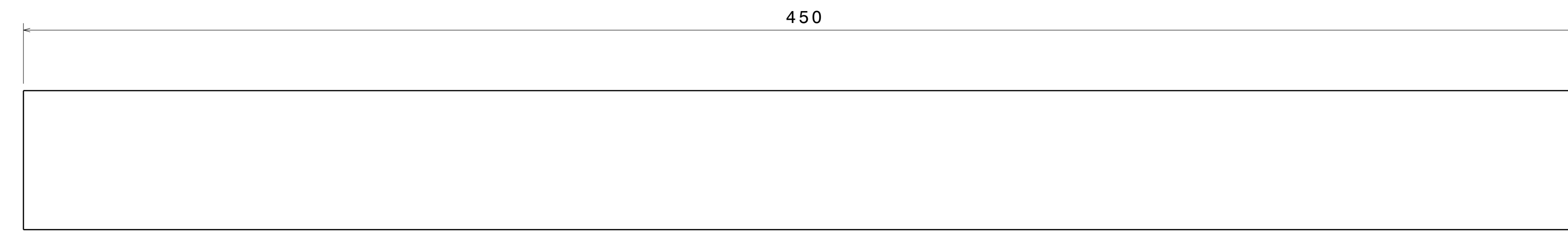

ITEM 1

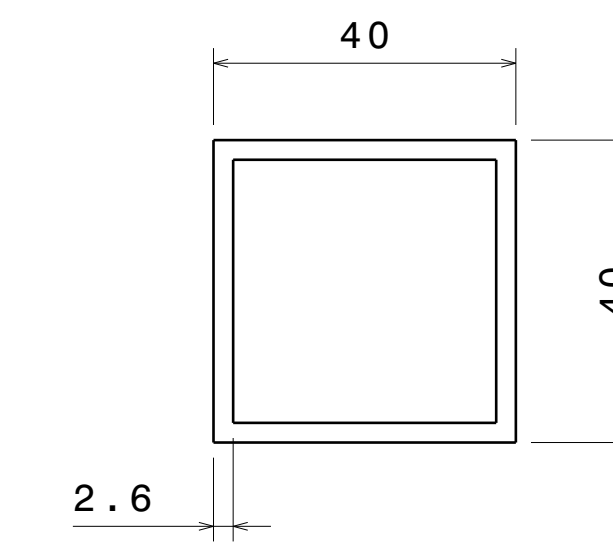

Right view
Scale: 1:1

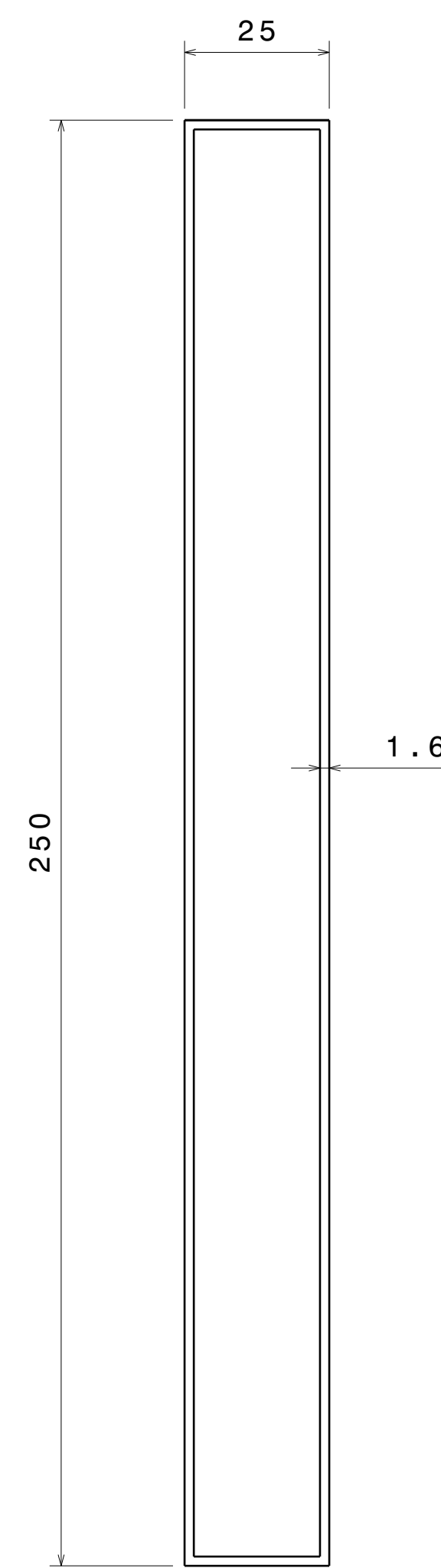

ITEM 2

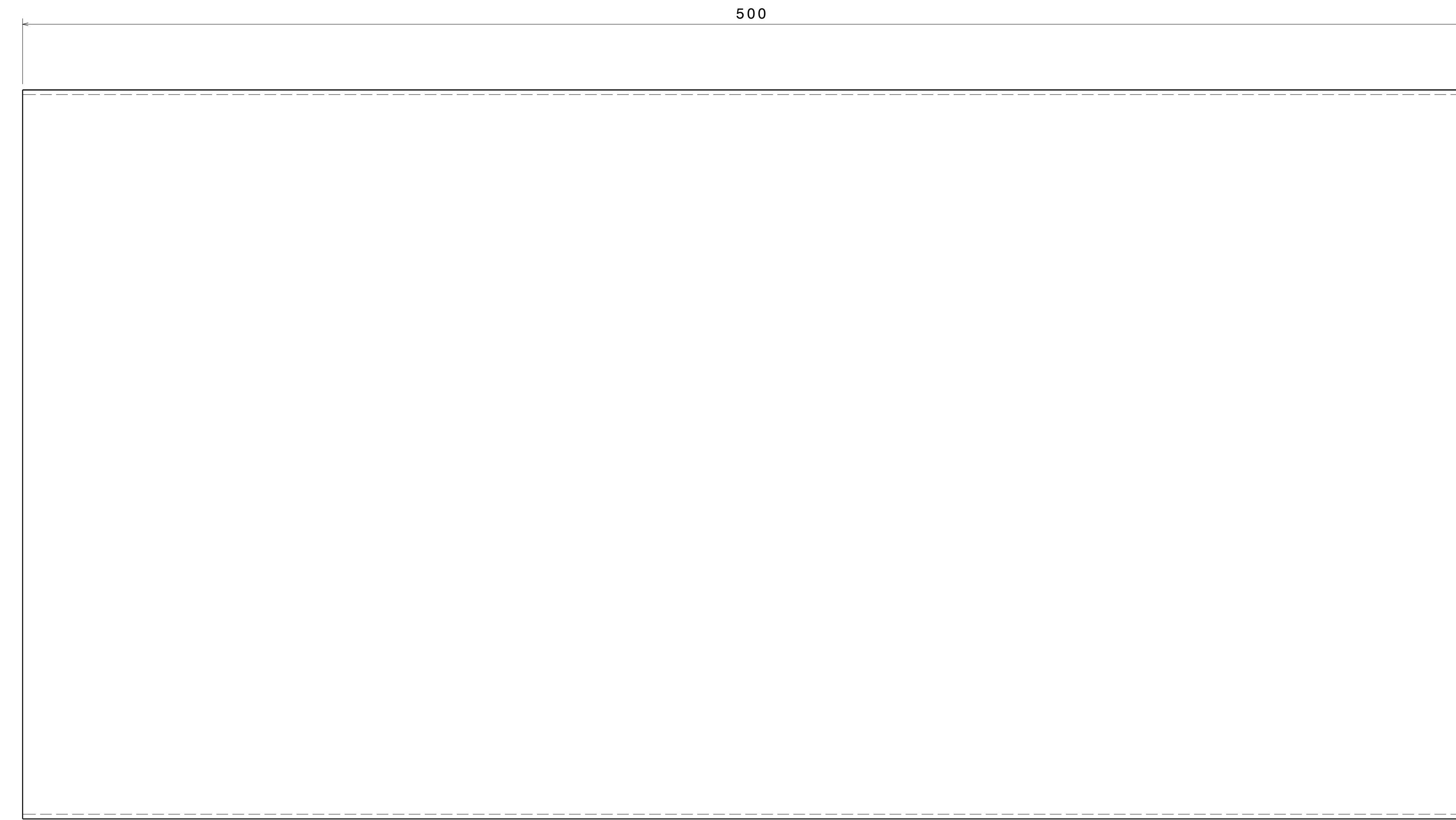

Right view
Scale: 1:1

UNLESS OTHERWISE SPECIFIED DIMENSION ARE IN MM
VIEWS: THIRD ANGLE PROJECTION

This drawing is our property. It can't be reproduced or communicated without our written agreement.		APL APOLLO TUBES LTD.	
DRAWN BY SB		DATE 28JUL2020	
CHECKED BY P2P Analysis & Solutions		DATE 28JUL2020	
DESIGNED BY P2P Analysis & Solutions		DATE 28JUL2020	
SIZE A0	DRAWING NUMBER P2P TABLE TOP		REV 00
SCALE NONE	WEIGHT (kg)	XXX	SHEET 3 OF 3