

1

2

3

4

5

6

A

A

B

B

C

C

D

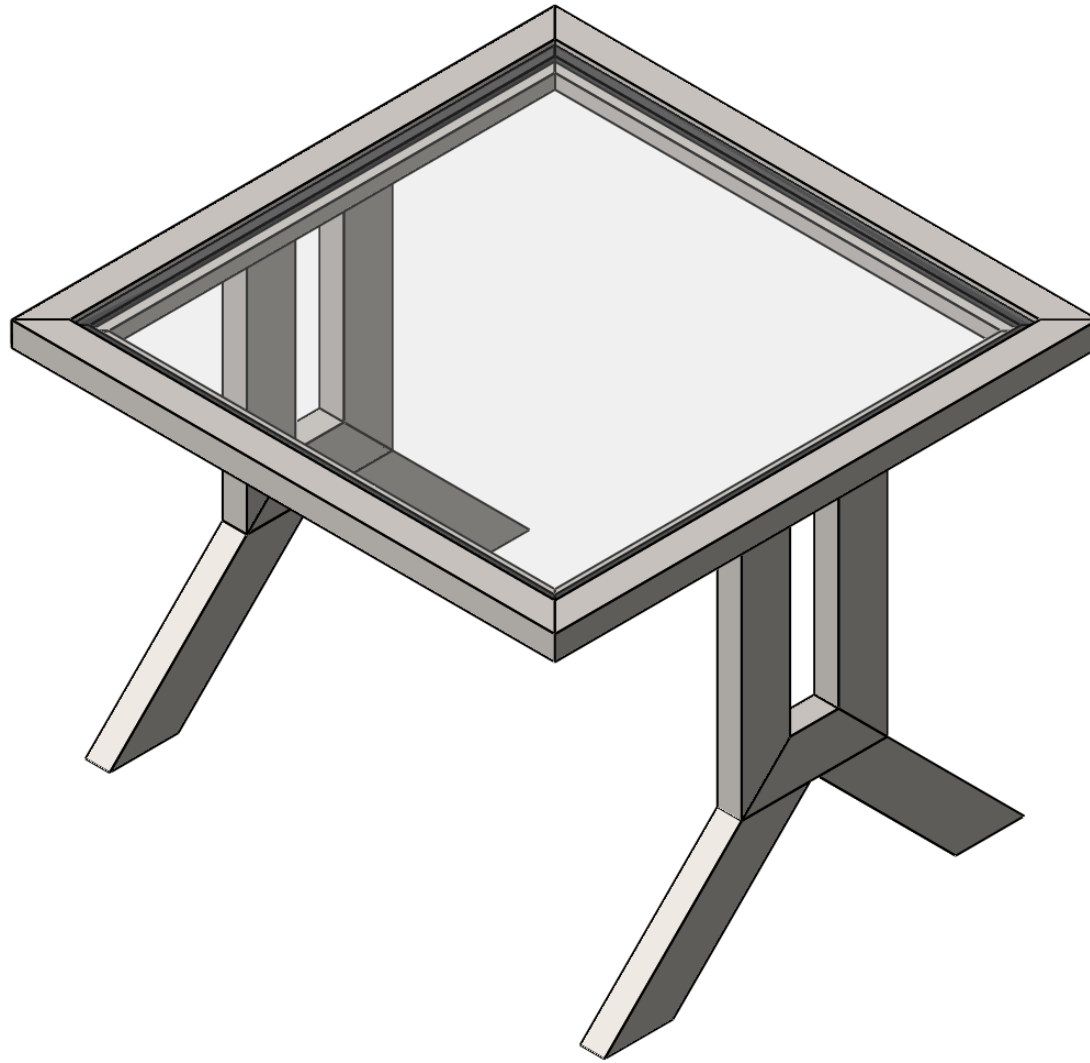

			DO NOT SCALE DRAWING		REVISION
			TITLE:		
	NAME	SIGNATURE	DATE	DWG NO. TABLE 2	
DRAWN					
CHK'D					
APPVD				SCALE:1:20	SHEET 1 OF 3
					A4

1

2

3

A4

NOTE :-

- ALL VERTICAL AND HORIZONTAL SUPPORTS ARE PERFECTLY 90°.
- ∇∇ SURFACE FINISH, MEDIUM TO SMOOTH IS USED.
- ALL TUBES ARE AS PER APL APOLLO STANDARD.
- FINE WELDING IS REQUIRED AS PER MENTION DETAILS AND FINISHING.
- JOINTS ARE WELD TOGETHER BY THE HIGH ACCURACY MIG WELDING.
- ALL DIMENSIONS ARE IN MM.
- HIGHER CURRENT WELDING MAY EFFECT THE BRITTLINESS OF MATERIAL WHICH MAY RAISE TO WEAKENING OF STRUCTURE.

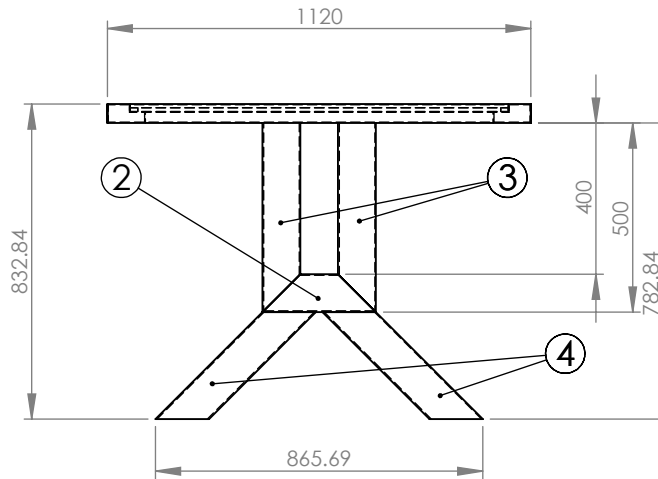
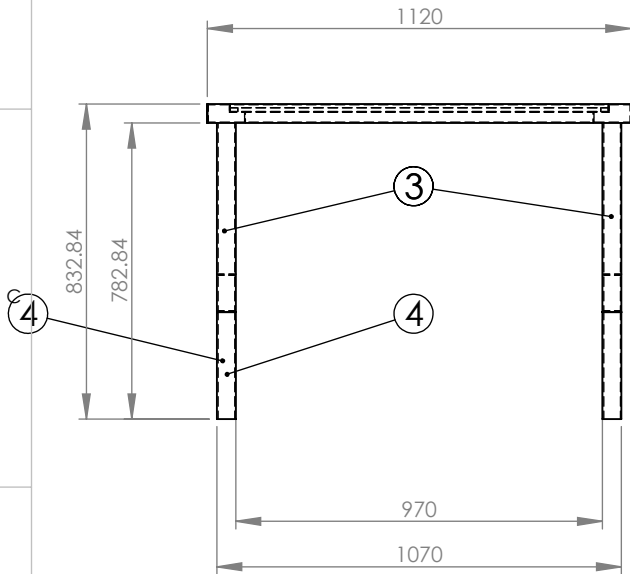
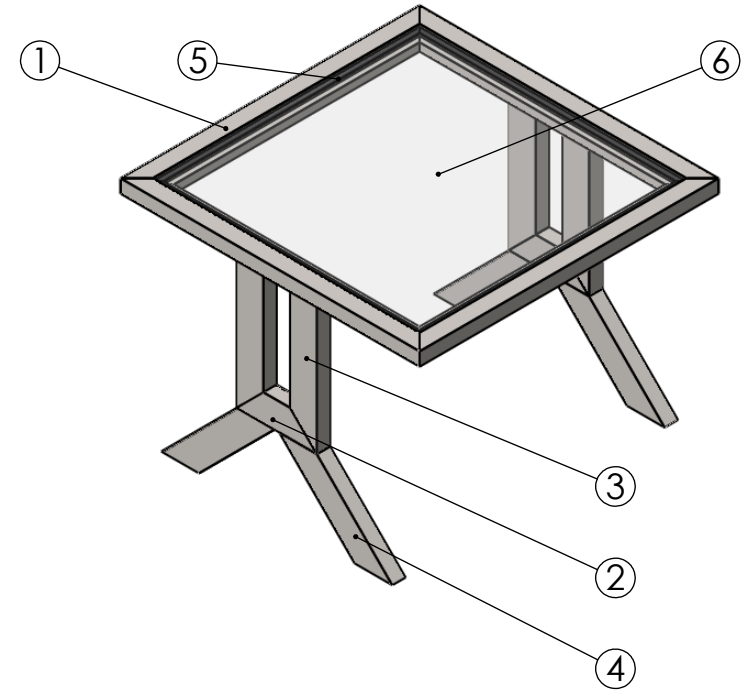
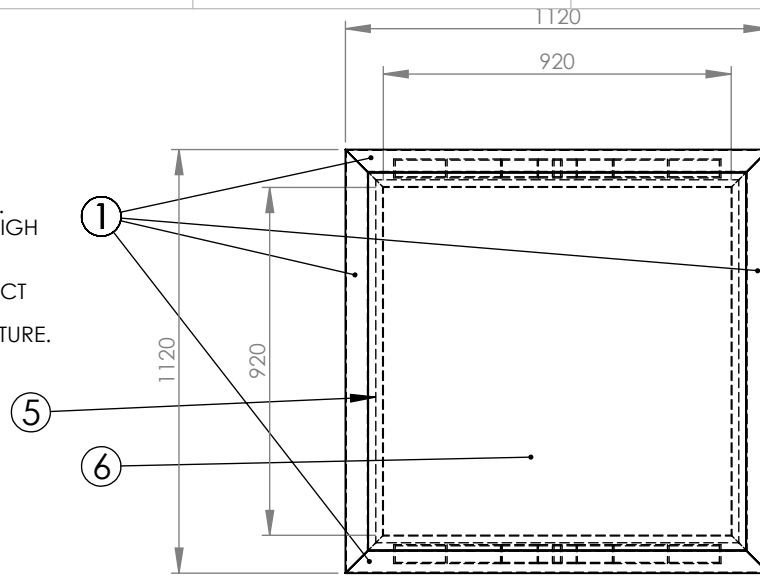

ITEM NO.	PART NUMBER	DESCRIPTION	QTY.	Unit
1	SDF 100X50X2.0X1200	SDF	4	4800
2	100X50X3X300	RHS	2	600
3	100X50X3X500	RHS	4	2000
4	100X50X3X500 (2)	RHS	4	2000
5	RUBBER	RUBBER	4	
6	TOUGHENED GLASS 1000X1000X10	GLASS	1	



DO NOT SCALE DRAWING			REVISION	
TITLE:				
DRAWN			DWG NO.	
CHK'D			TABLE 2	
APPVD			SCALE:1:20	
			SHEET 2 OF 3	
			A4	

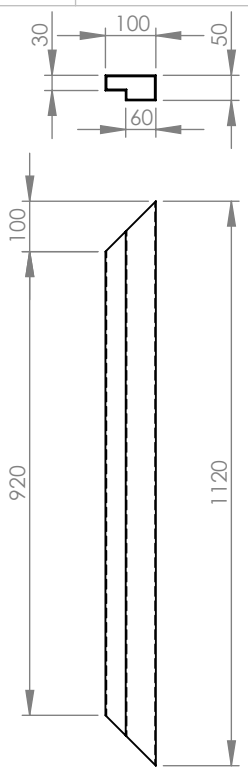

ITEM 1
SDF 100X50X2.0X1200

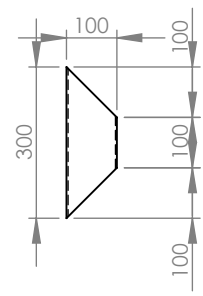

ITEM 2
SHS 100X50X3.0X300

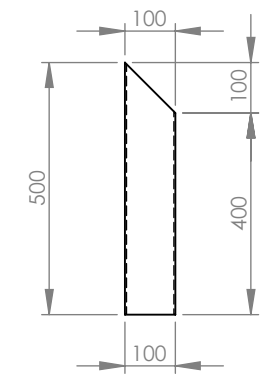

ITEM 3
SHS 100X50X3.0X500

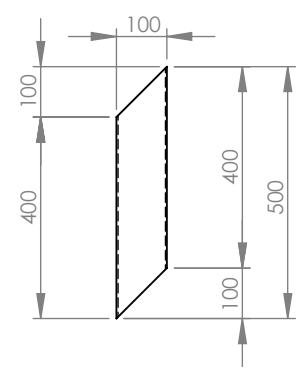

ITEM 4
SHS 100X50X3.0X500 (2)



DO NOT SCALE DRAWING REVISION

TITLE: PART DRAWINGS

	NAME	SIGNATURE	DATE
DRAWN			
CHK'D			
APPV'D			

DWG NO. TABLE 2