

| | | | | | |
|---|------|-----------|----------------------|---------------------|--------------|
|  | | | DO NOT SCALE DRAWING | REVISION | |
| | | | TITLE: | | |
| | NAME | SIGNATURE | DATE | DWG NO. SOFA | |
| DRAWN | | | | | |
| CHK'D | | | | | |
| APPVD | | | | SCALE:1:50 | SHEET 1 OF 3 |
| | | | | | A4 |

- NOTE :-
- ALL VERTICAL AND HORIZONTAL SUPPORTS ARE PERFECTLY 90°.
 - ∇∇ SURFACE FINISH, MEDIUM TO SMOOTH IS USED.
 - ALL TUBES ARE AS PER APL APOLLO STANDARD.
 - FINE WELDING IS REQUIRED AS PER MENTION DETAILS AND FINISHING.
 - JOINTS ARE WELD TOGETHER BY THE HIGH ACCURACY MIG WELDING.
 - ALL DIMENSIONS ARE IN MM.
 - HIGHER CURRENT WELDING MAY EFFECT THE BRITTLENESS OF MATERIAL WHICH MAY RAISE TO WEAKENING OF STRUCTURE.

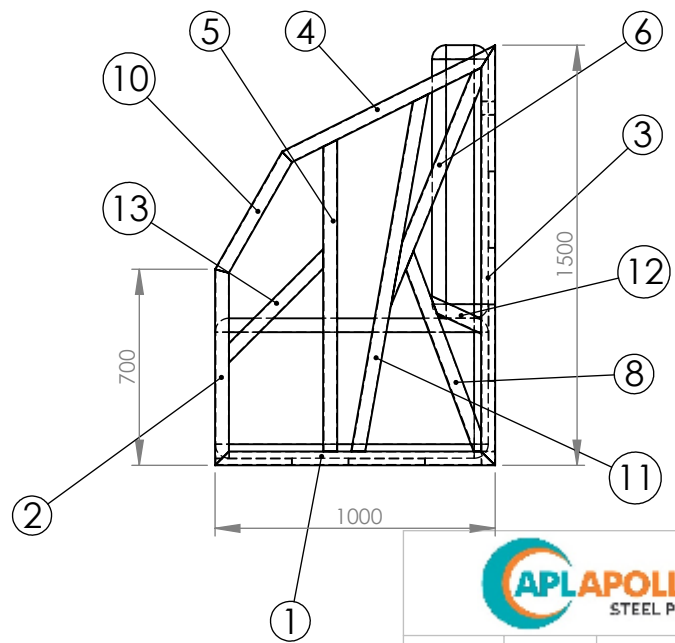

| ITEM NO. | PART NUMBER | DESCRIPTION | QTY. | Unit |
|----------|-----------------------|-------------|------|---------|
| 1 | 50X50X2X1000 | SHS | 2 | 2000 |
| 2 | 50X50X2X700 | SHS | 2 | 1400 |
| 3 | 50X50X2X1500 | SHS | 2 | 3000 |
| 4 | 50X50X2X850 | SHS | 2 | 1700 |
| 5 | 50X50X2X1112.06 | SHS | 2 | 2224.12 |
| 6 | 50X50X2X907.21 | SHS | 2 | 1814.42 |
| 7 | 50X50X2X2000 | SHS | 2 | 4000 |
| 8 | 50X50X2X755.33 | SHS | 2 | 1510.66 |
| 9 | PLANK 275X25X2.0X2000 | RHS | 4 | 8000 |
| 10 | 50X50X2X483.45 | SHS | 2 | 966.90 |
| 11 | 50X50X2X1303.37 | SHS | 2 | 2606.74 |
| 12 | 50X50X2X222.36 | SHS | 2 | 444.72 |
| 13 | 50X50X2X525.26 | SHS | 2 | 1050.52 |
| 14 | Cushion | | 2 | |
| 15 | Cushion 2 | | 2 | |

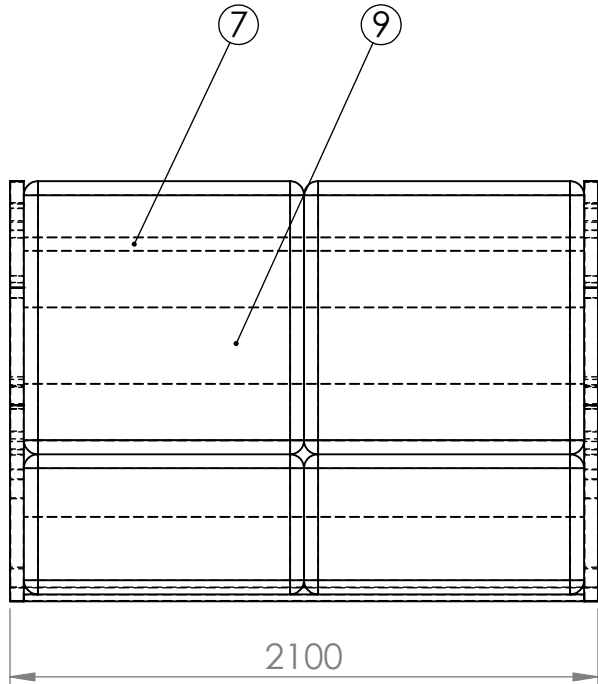
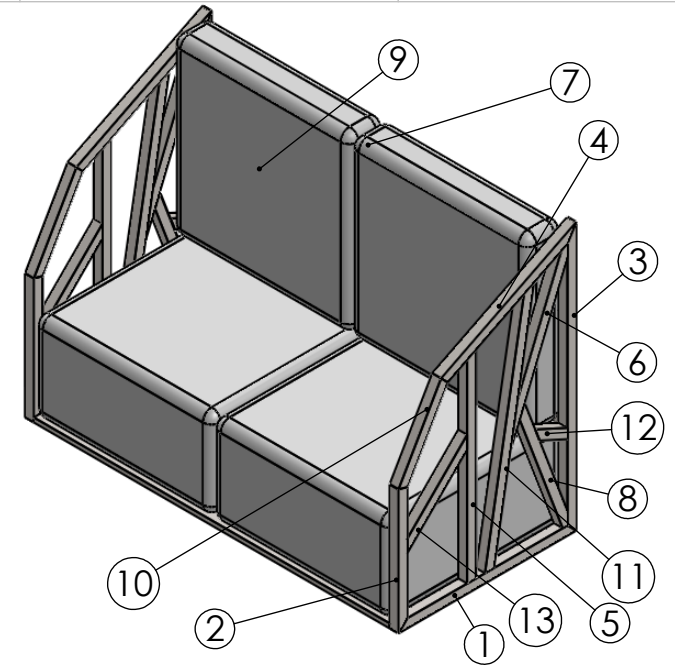
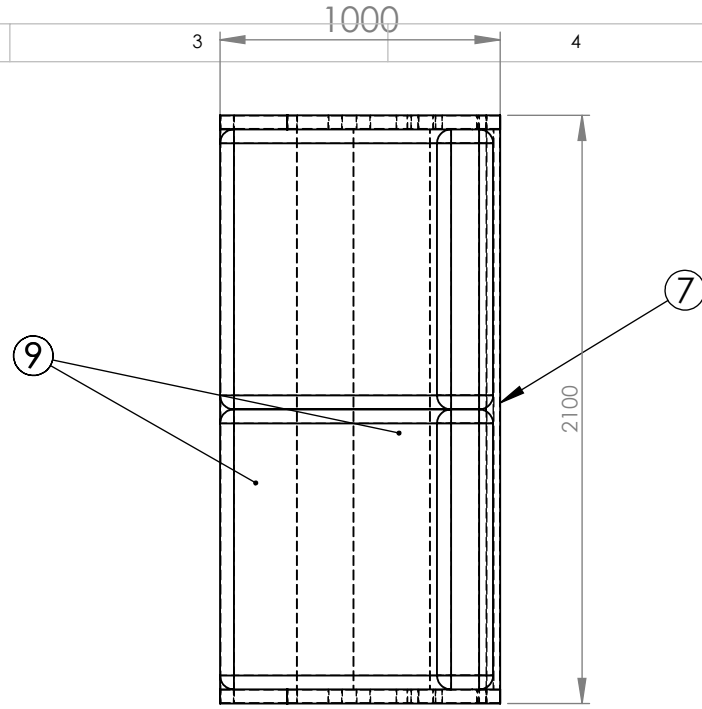

| | NAME | SIGNATURE | DATE |
|-------|------|-----------|------|
| DRAWN | | | |
| CHK'D | | | |
| APPVD | | | |

DO NOT SCALE DRAWING REVISION

TITLE:

DWG NO. SOFA

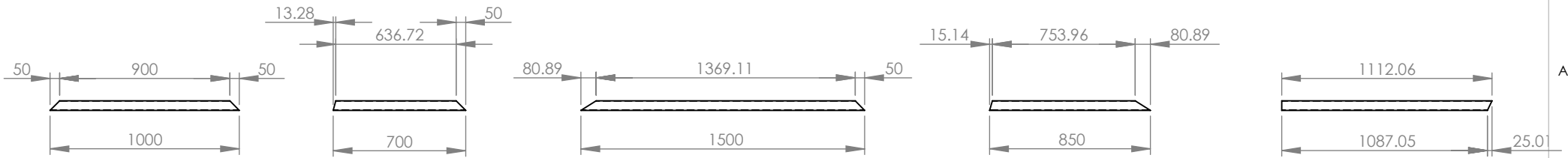

ITEM 1
SHS 50X50X2.0X1000

ITEM 2
SHS 50X50X2.0X700

ITEM 3
SHS 50X50X2.0X1500

ITEM 4
SHS 50X50X2.0X850

ITEM 5
SHS 50X50X2.0X1112.06

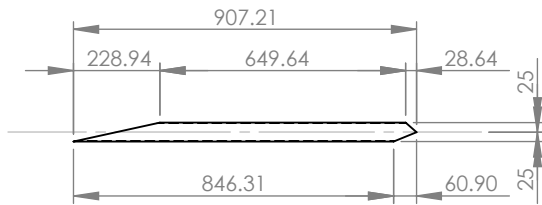

ITEM 6
SHS 50X50X2.0X907.21

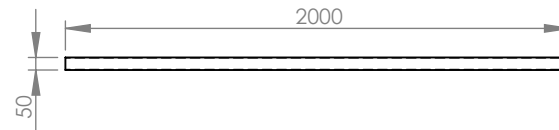

ITEM 7
SHS 50X50X2.0X2000

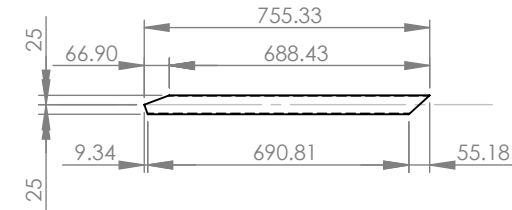

ITEM 8
SHS 50X50X2.0X755.33

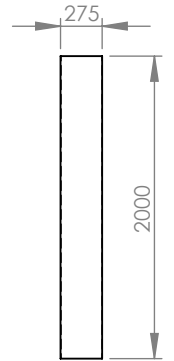

ITEM 9
PLANK 275X25X2.0X2000

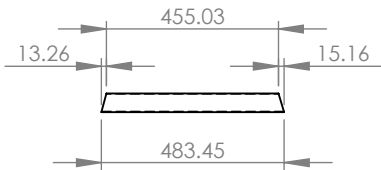

ITEM 10
SHS 50X50X2.0X485.03

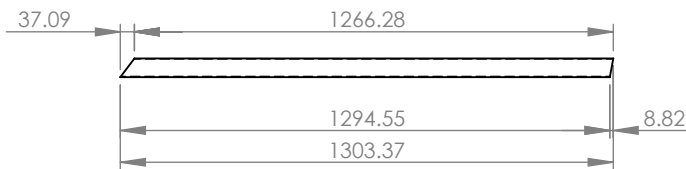

ITEM 11
SHS 50X50X2.0X1303.37

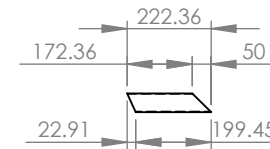

ITEM 12
SHS 50X50X2.0X222.36

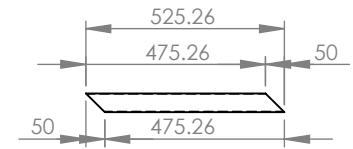

ITEM 13
SHS 50X50X2.0X525.26



DO NOT SCALE DRAWING

REVISION

TITLE:

PART DRAWINGS

| | NAME | SIGNATURE | DATE |
|-------|------|-----------|------|
| DRAWN | | | |
| CHK'D | | | |
| APPVD | | | |

DWG NO.

SOFA

SCALE:1:50

SHEET 3 OF 3

A4