			DO NOT SCALE DRAWING		REVISION
			TITLE:		
	NAME	SIGNATURE	DATE	DWG NO. CENTER TABLE 6	
DRAWN					
CHK'D					
APPVD				SCALE:1:20	SHEET 1 OF 3

A

B

C

D

A

B

C

D

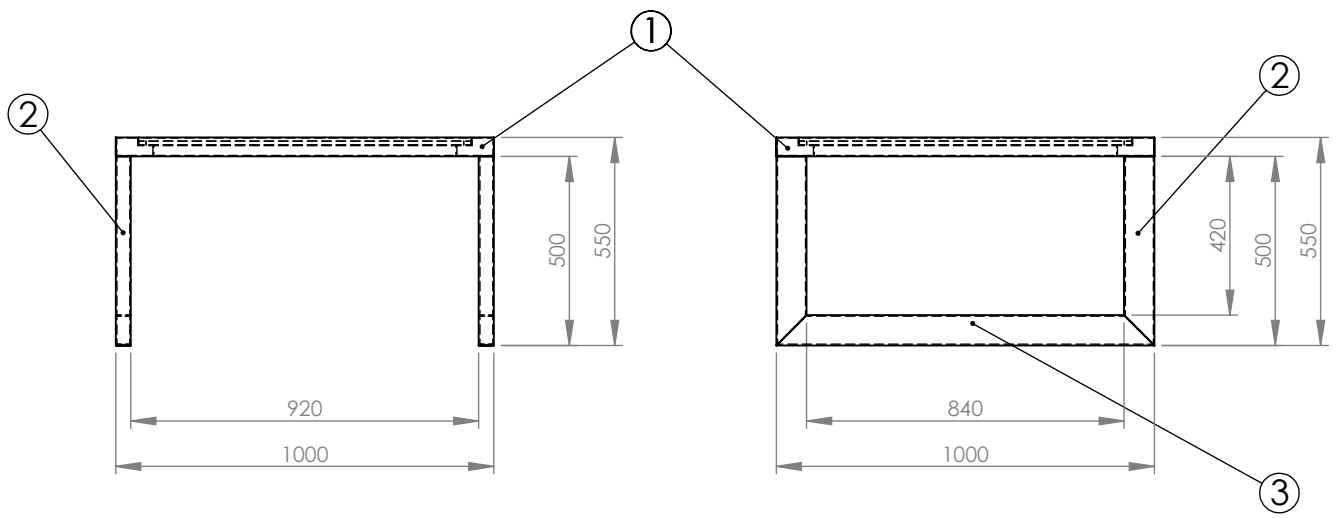
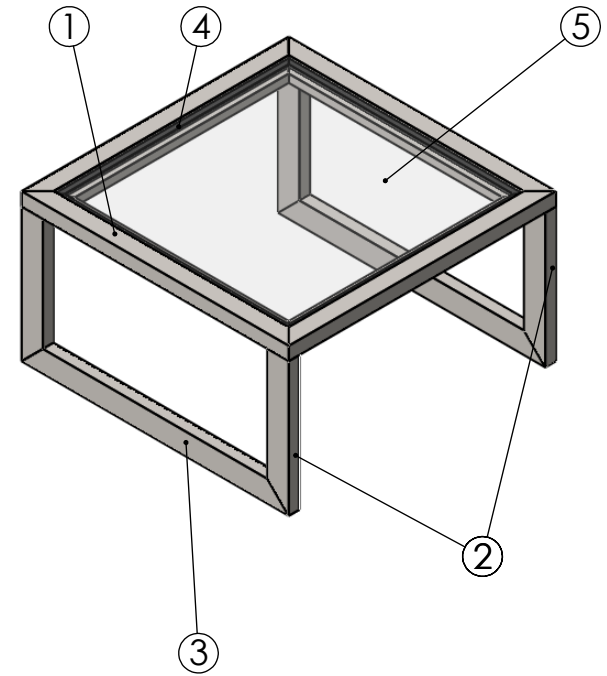
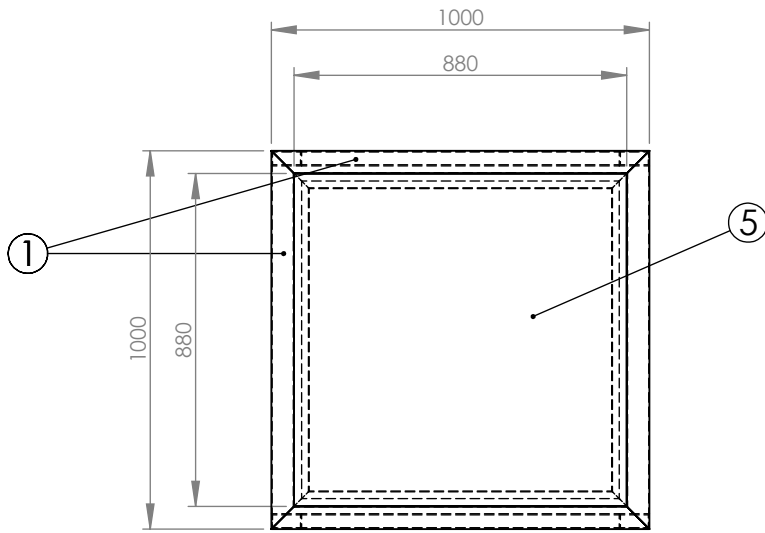

NOTE :-

- ALL VERTICAL AND HORIZONTAL SUPPORTS ARE PERFECTLY 90°.
- ∇∇ SURFACE FINISH, MEDIUM TO SMOOTH IS USED.
- ALL TUBES ARE AS PER APL APOLLO STANDARD.
- FINE WELDING IS REQUIRED AS PER MENTION DETAILS AND FINISHING.
- JOINTS ARE WELD TOGETHER BY THE HIGH ACCURACY MIG WELDING.
- ALL DIMENSIONS ARE IN MM.
- HIGHER CURRENT WELDING MAY EFFECT THE BRITTLENESS OF MATERIAL WHICH MAY RAISE TO WEAKENING OF STRUCTURE.

ITEM NO.	PART NUMBER	DESCRIPTION	QTY.	Unit
1	SDF 100X50X2.0X1000	RHS	4	4000
2	80X40X3X500	RHS	4	2000
3	80X40X3X1000	RHS	2	2000
4	RUBBER 880	RHS	4	
5	TOUGHENED GLASS 880X880X10		1	

		DO NOT SCALE DRAWING		REVISION
		TITLE:		
NAME	SIGNATURE	DATE	DWG NO. CENTER TABLE 6	
DRAWN				
CHK'D				
APPVD			SCALE:1:20	SHEET 2 OF 3

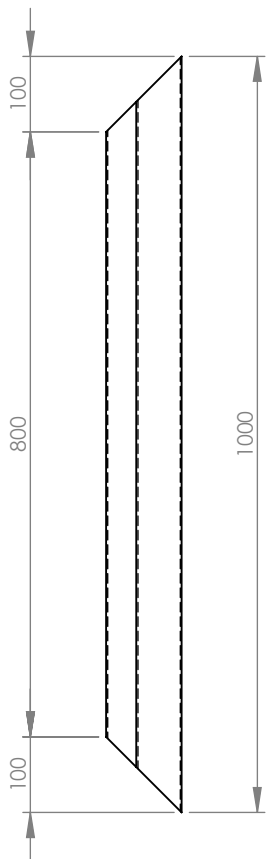
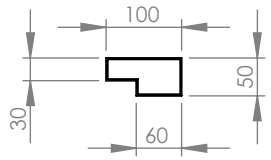

ITEM 1
SDF 100X50X2.0X1000

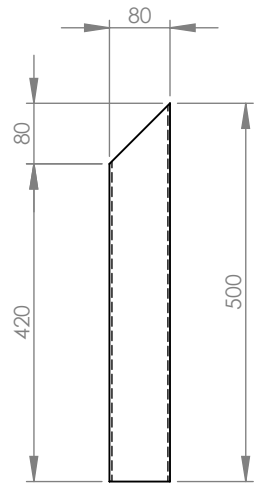

ITEM 2
RHS 80X40X3.0X500

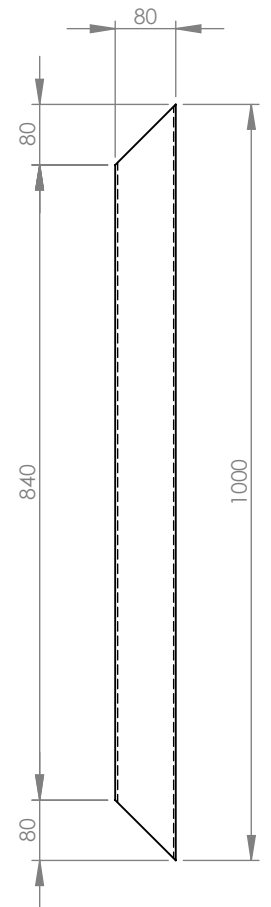

ITEM 3
RHS 80X40X3.0X1000

DRAWN			
CHK'D			
APPVD			

DO NOT SCALE DRAWING	REVISION
TITLE: PART DRAWINGS	
DWG NO. CENTER TABLE 6	
SCALE:1:20	SHEET 3 OF 3