

REV/DATE	DESCRIPTION
00 10JUN2020	INITIAL REVISION

NOTES:

- (⊥) ALL VERTICAL SUPPORTS ARE PERPENDICULAR.
- FLATNESS OF .5MM IS APPLIED BY DEFAULT.
- ⊲ WELD BEAD OF 2MM RADIUS IS FOLLOWED.
- ▽ SURFACE FINISH MEDIUM TO SMOOTH IS USED.
- ALL TUBES ARE AS PER APL APOLLO STANDARD. CHANGES MAY EFFECT THE LOAD CAPACITY.
- ALL HORIZONTAL AND VERTICAL TUBES ARE PERPENDICULAR TO EACH OTHER WITH ±1 DEG.
- FINE WELDNG IS REQUIRED AS PER MENTIONED DETAILS AND FINISHING.
- HIGHER CURRENT WELDING MAY AFFECT THE BRITTLENESS OF MATERIAL WHICH LATER MAY RAISE TO WEAKENING OF STRUCTURE.
- FABRICATORS ARE ALLOWED TO USE FITTINGS/FRAMES/SUPPORTS AS NEEDED AND THE SAME MUST BE COMMUNICATED BACK TO ENGINEERING TEAM.
- LENGTH OF ALL LONGITUDINAL FRAMES ARE FOR REFERENCE ONLY AND SUBJECTED TO CHANGE PER REQUIREMENT.

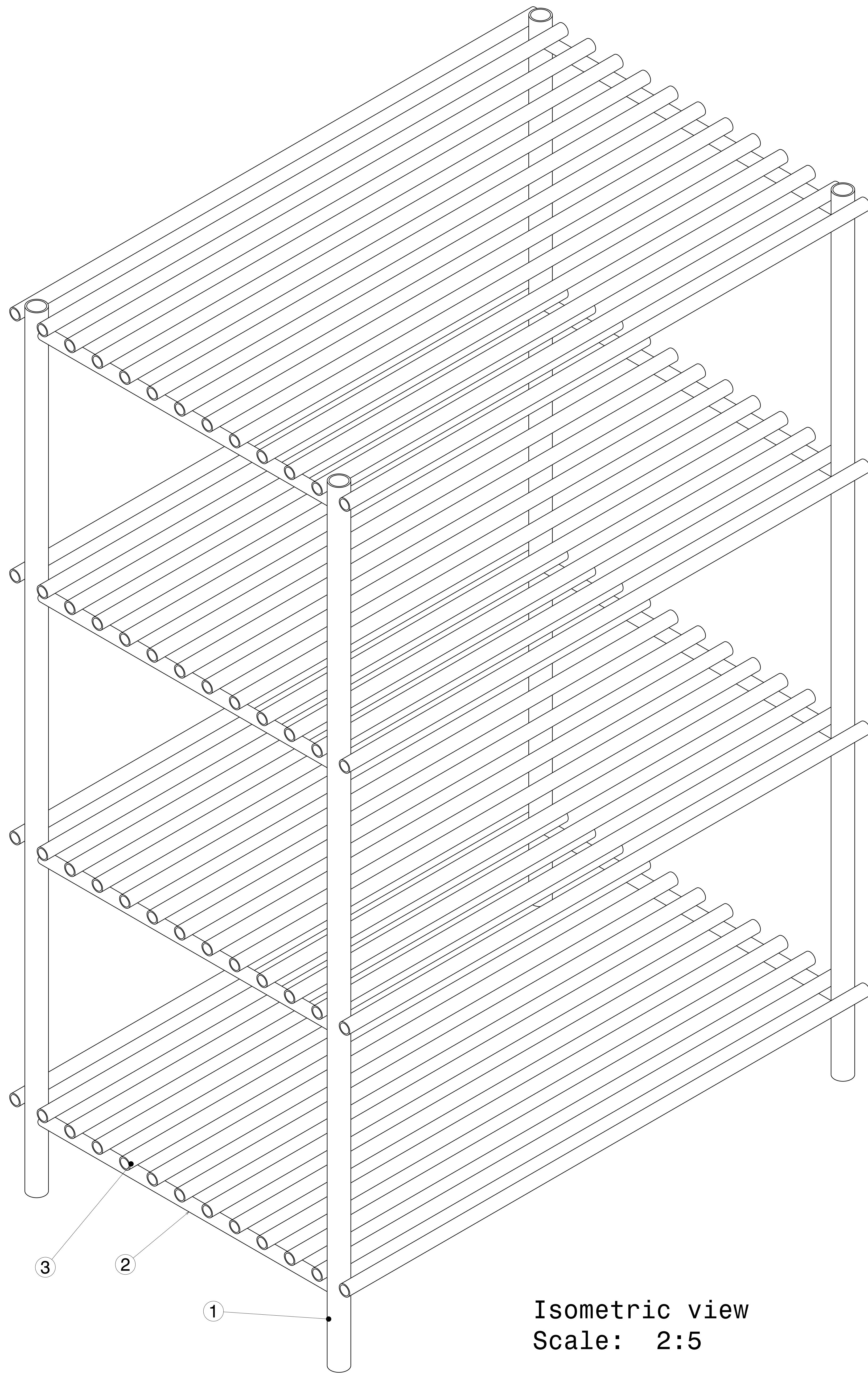

Isometric view  
Scale: 2:5

ITEM NO.	PART NUMBER	DESCRIPTION	QTY.	Wt (Kg)/Each
3	MAY 12 Frame 3	DIA 21 X 2 X 1033	52	1
2	MAY 12 Frame 2	DIA 21 X 2 X 600	8	0.57
1	MAY 12 Frame 1	DIA 33.2 X 2.6 X 1520	4	3

This drawing is our property. It can't be reproduced or communicated without our written agreement.		<b>APL APOLLO TUBES LTD.</b> 	
DRAWING TITLE		MAY 12	
DRAWN BY SB	DATE 10JUN2020	SIZE A0	DRAWING NUMBER P2P MAY 12
CHECKED BY P2P Analysis & Solutions	DATE 10JUN2020	SCALE As Indicated	REV 00
DESIGNED BY P2P Analysis & Solutions	DATE 10JUN2020	WEIGHT(kg) 0kg	SHEET 1 OF 3

UNLESS OTHERWISE SPECIFIED DIMENSION ARE IN MM  
VIEWS: THIRD ANGLE PROJECTION



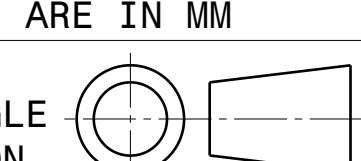

REV	DATE	DESCRIPTION
00	10JUN2020	INITIAL REVISION

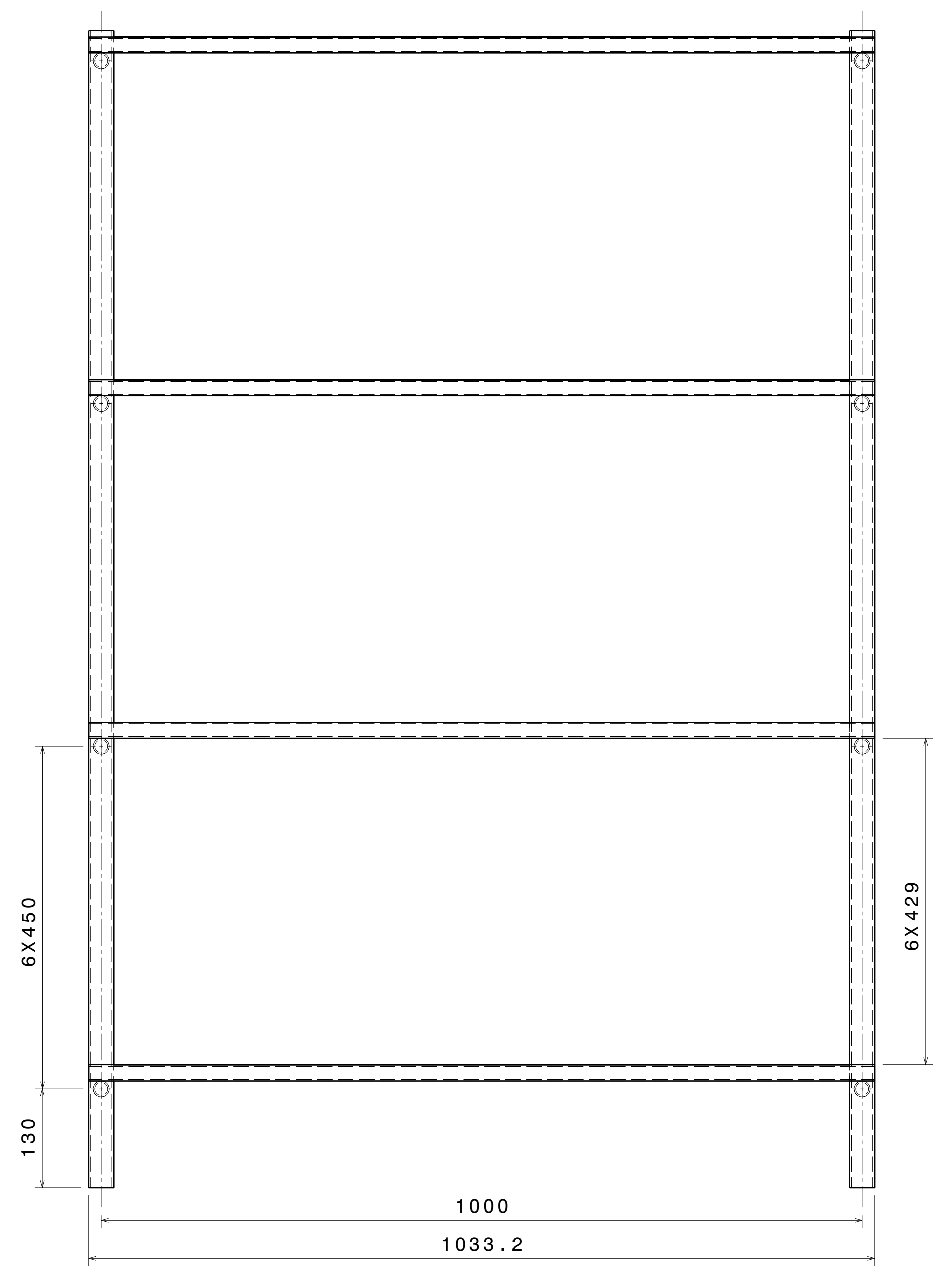

Front view  
Scale: 1:5

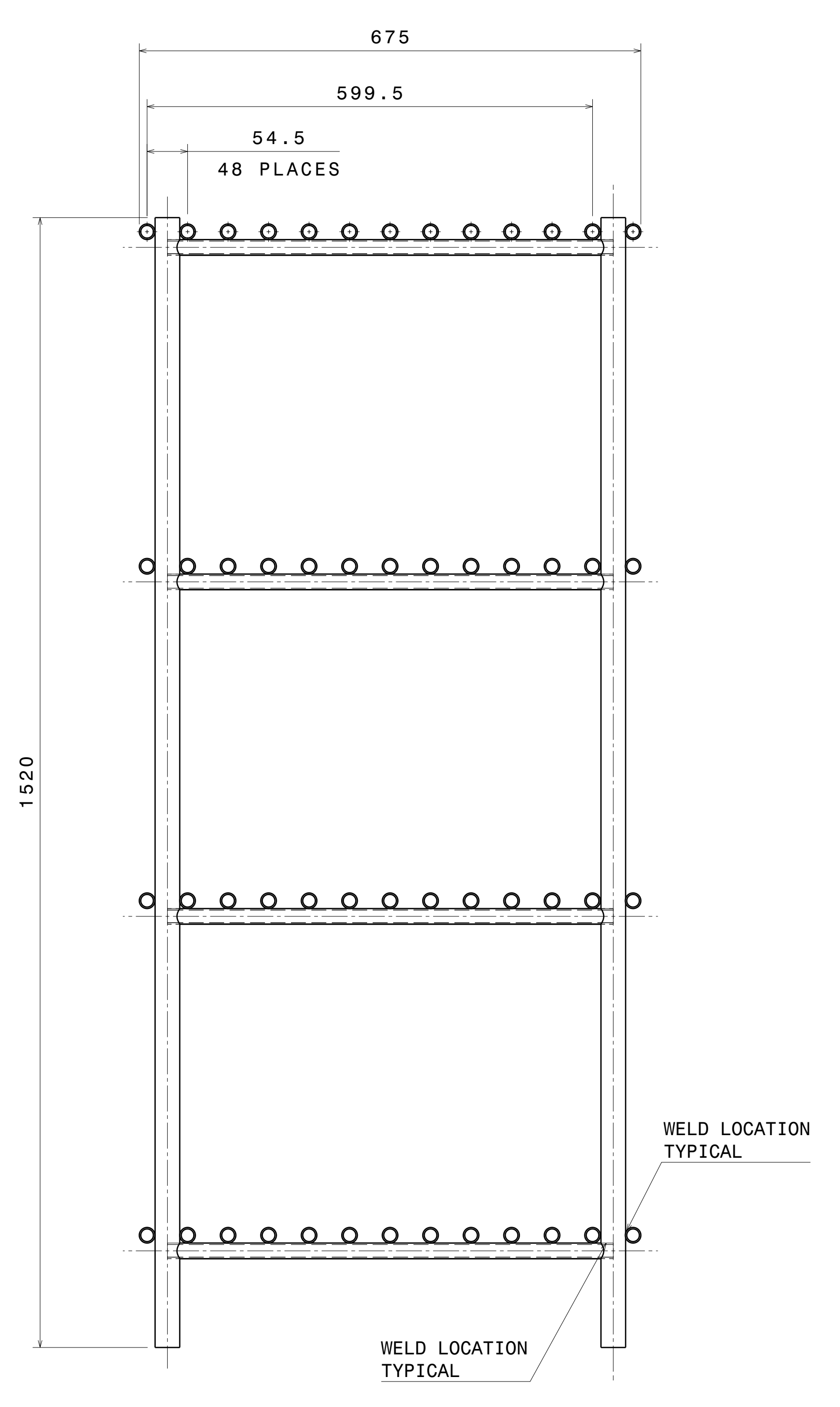

Right view  
Scale: 1:5

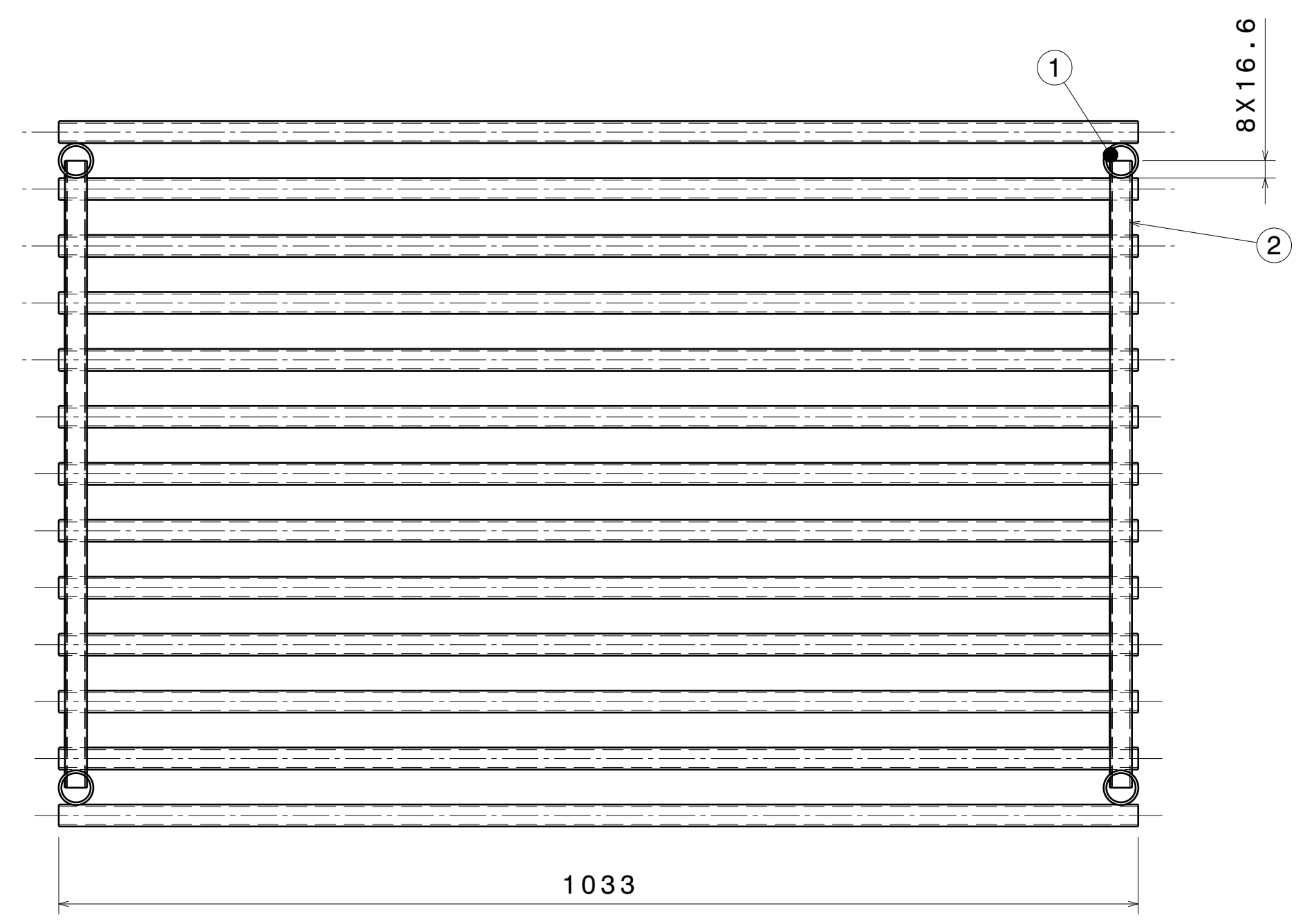

Bottom view  
Scale: 1:5

UNLESS OTHERWISE SPECIFIED DIMENSION ARE IN MM  
VIEWS: THIRD ANGLE PROJECTION

This drawing is our property. It can't be reproduced or communicated without our written agreement.		APL APOLLO TUBES LTD.	
DRAWN BY SB		DATE 10JUN2020	
CHECKED BY P2P Analysis & Solutions		DATE 10JUN2020	
DESIGNED BY P2P Analysis & Solutions		DATE 10JUN2020	
SIZE A0	DRAWING NUMBER P2P MAY 12	REV 00	
SCALE NONE	WEIGHT (kg) XXX	SHEET 2 OF 3	

REV	DATE	DESCRIPTION
00	10JUN2020	INITIAL REVISION

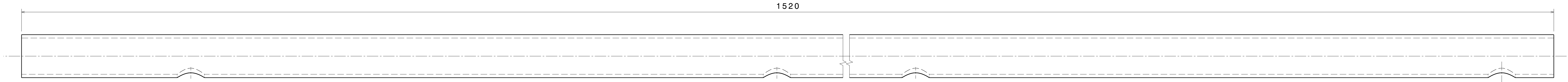

ITEM 1

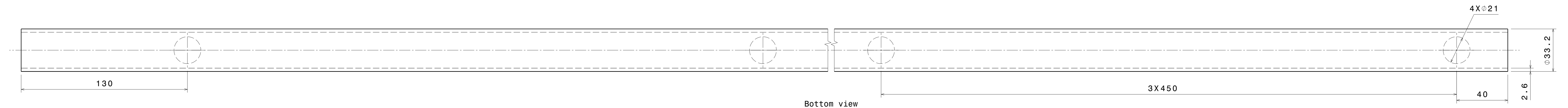

Bottom view

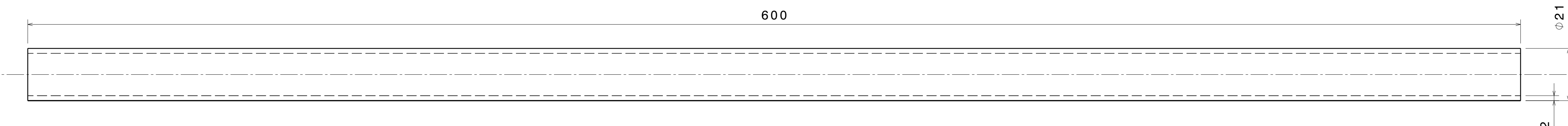

ITEM 2

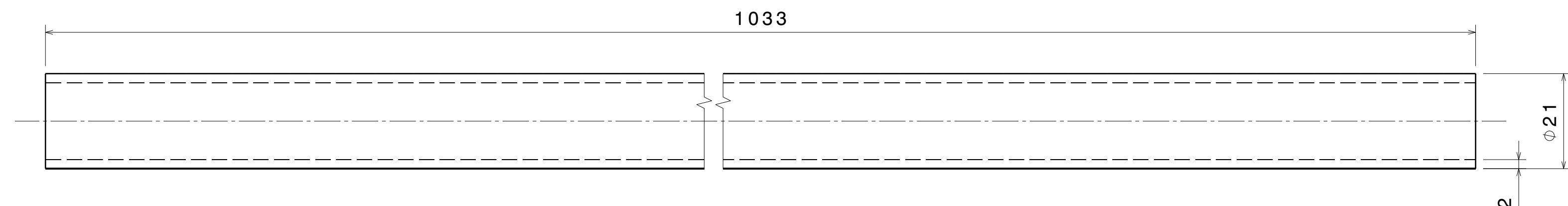

ITEM 3

UNLESS OTHERWISE SPECIFIED DIMENSION ARE IN MM  
 VIEWS: THIRD ANGLE PROJECTION

This drawing is our property. It can't be reproduced or communicated without our written agreement.		APL APOLLO TUBES LTD.	
DRAWN BY SB		DATE 10JUN2020	
CHECKED BY P2P Analysis & Solutions		DATE 10JUN2020	
DESIGNED BY P2P Analysis & Solutions		DATE 10JUN2020	
DRAWING TITLE MAY 12		SIZE A0	DRAWING NUMBER P2P_MAY 12
SCALE NONE		WEIGHT (kg) XXX	REV 00
		SHEET 3 OF 3	