

REV	DATE	DESCRIPTION
00	29MAR2020	INITIAL REVISION

NOTES:

- (⊥) ALL VERTICAL SUPPORTS ARE PERPENDICULAR.
- FLATNESS OF .5MM IS APPLIED BY DEFAULT.
- ⊥ WELD BEAD OF 2MM RADIUS IS FOLLOWED.
- ▽ SURFACE FINISH MEDIUM TO SMOOTH IS USED.
- ALL TUBES ARE AS PER APL APOLLO STANDARD. CHANGES MAY EFFECT THE LOAD CAPACITY.
- ALL HORIZONTAL AND VERTICAL TUBES ARE PERPENDICULAR TO EACH OTHER WITH ±1 DEG.
- FINE WELDING IS REQUIRED AS PER MENTIONED DETAILS AND FINISHING.
- HIGHER CURRENT WELDING MAY AFFECT THE BRITTLENESS OF MATERIAL WHICH LATER MAY RAISE TO WEAKENING OF STRUCTURE.
- FABRICATORS ARE ALLOWED TO USE FITTINGS/FRAMES/SUPPORTS AS NEEDED AND THE SAME MUST BE COMMUNICATED BACK TO ENGINEERING TEAM.
- LENGTH OF ALL LONGITUDINAL FRAMES ARE FOR REFERENCE ONLY AND SUBJECTED TO CHANGE PER REQUIREMENT.
- WEIGHT MAY CHANGE IF NEEDED.

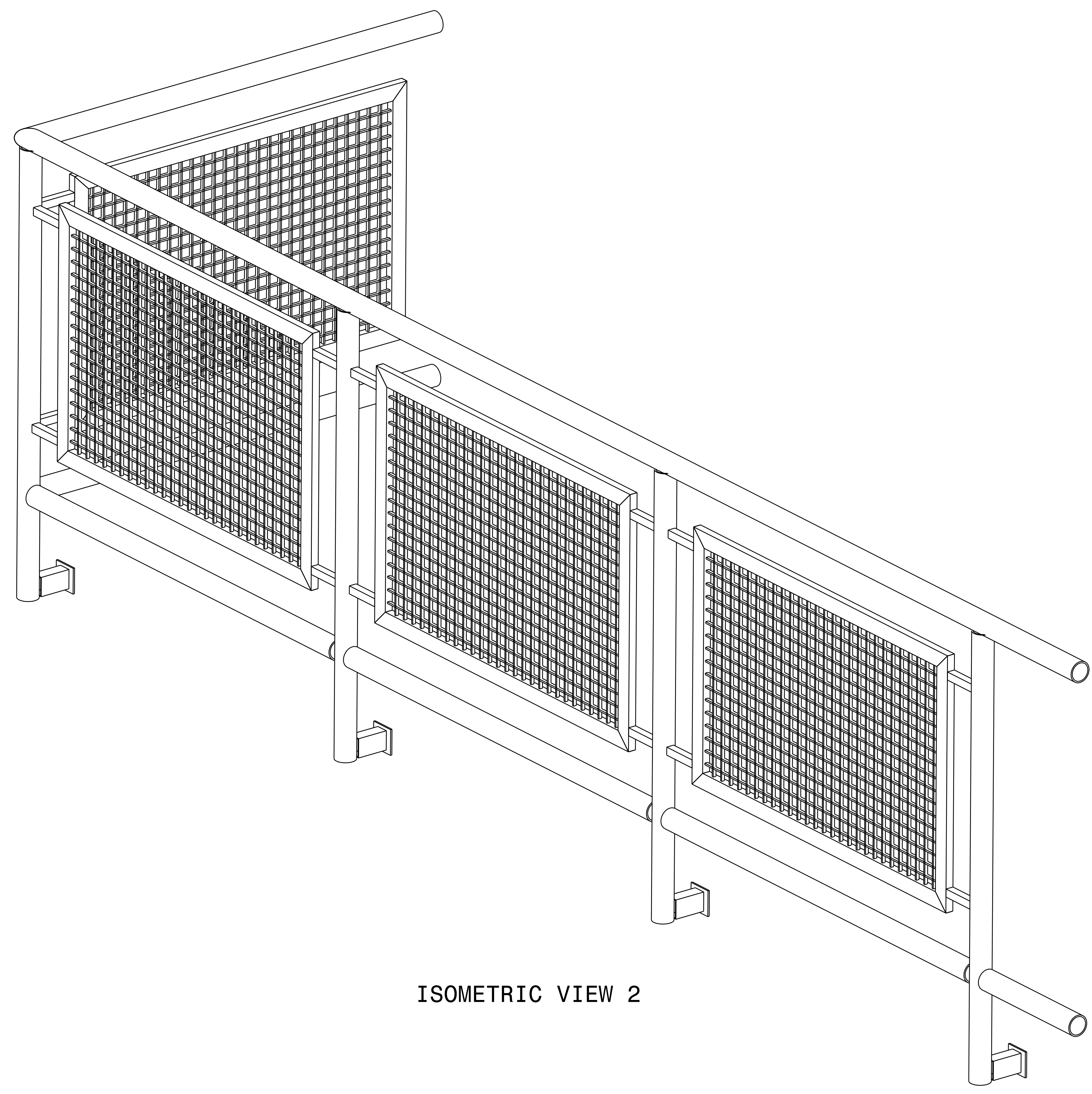

ISOMETRIC VIEW 2

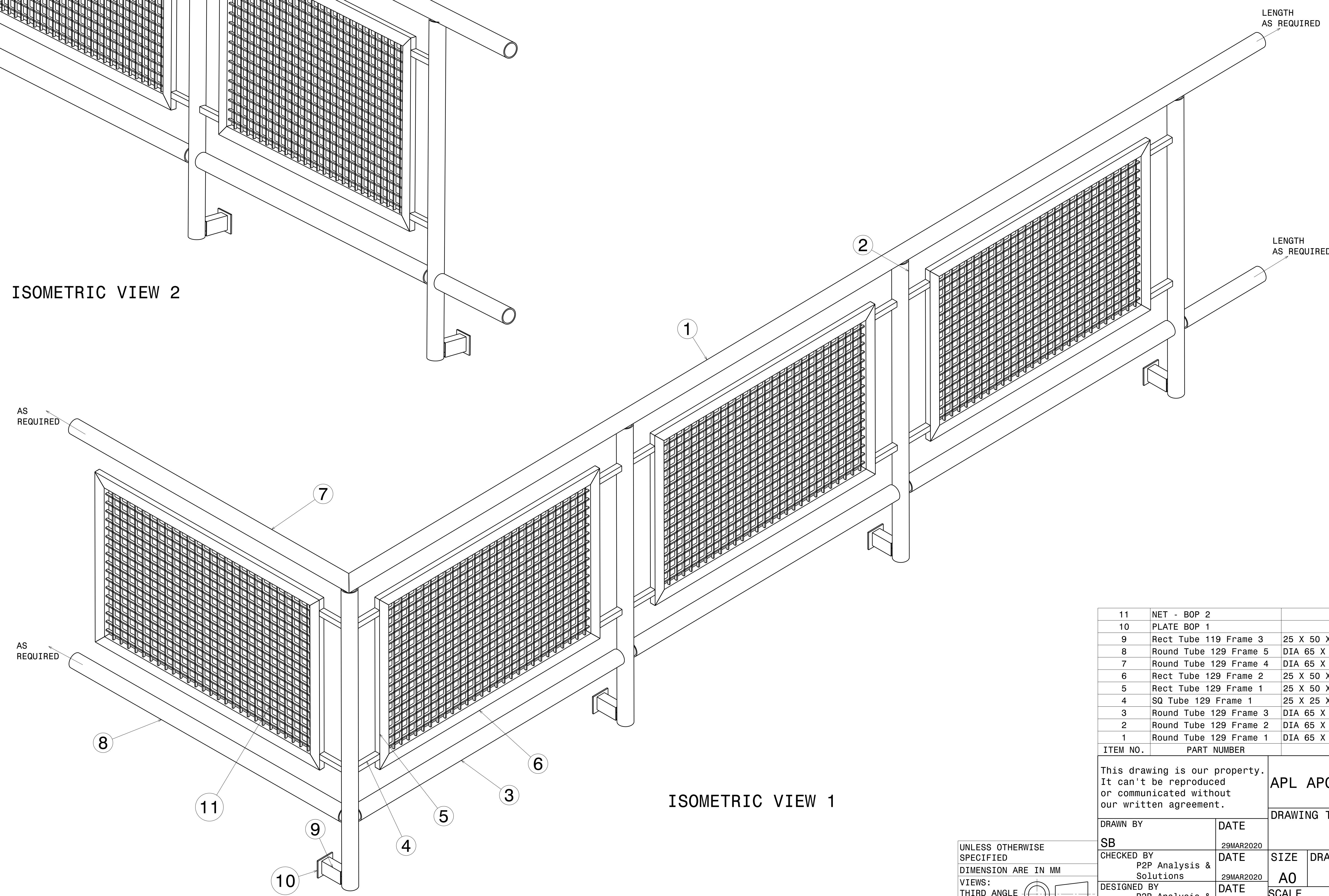

ISOMETRIC VIEW 1

ITEM NO.	PART NUMBER	DESCRIPTION	QTY.	Wt(Kg)/Each
11	NET - BOP 2		AS REQ	
10	PLATE BOP 1		AS REQ	.25
9	Rect Tube 119 Frame 3	25 X 50 X 2 X 100	AS REQ	.3
8	Round Tube 129 Frame 5	DIA 65 X 4.5 X AS REQUIRED	AS REQ	9.7 (REF NOTE 11)
7	Round Tube 129 Frame 4	DIA 65 X 4.5 X AS REQUIRED	AS REQ	9.9 (REF NOTE 11)
6	Rect Tube 129 Frame 2	25 X 50 X 2 X 1200	AS REQ	2.6
5	Rect Tube 129 Frame 1	25 X 50 X 2 X 800	AS REQ	1.7
4	SQ Tube 129 Frame 1	25 X 25 X 1.6 X 120	AS REQ	.18
3	Round Tube 129 Frame 3	DIA 65 X 4.5 X 1432	AS REQ	9.7
2	Round Tube 129 Frame 2	DIA 65 X 4.5 X 1400	AS REQ	9.5
1	Round Tube 129 Frame 1	DIA 65 X 4.5 X AS REQUIRED	1	33.5 (REF NOTE 11)

This drawing is our property. It can't be reproduced or communicated without our written agreement.		APL APOLLO TUBES LTD. 	
DRAWN BY SB		DATE 29MAR2020	
CHECKED BY P2P Analysis & Solutions		DATE 29MAR2020	
DESIGNED BY P2P Analysis & Solutions		DATE 29MAR2020	
DRAWING TITLE HAND RAIL 129		SIZE A0	DRAWING NUMBER P2P HANDRAIL 000129
SCALE As Indicated		WEIGHT(kg) 0kg	REV 00

UNLESS OTHERWISE SPECIFIED DIMENSION ARE IN MM VIEWS: THIRD ANGLE PROJECTION

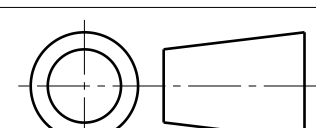

REV	DATE	DESCRIPTION
00	29MAR2020	INITIAL REVISION

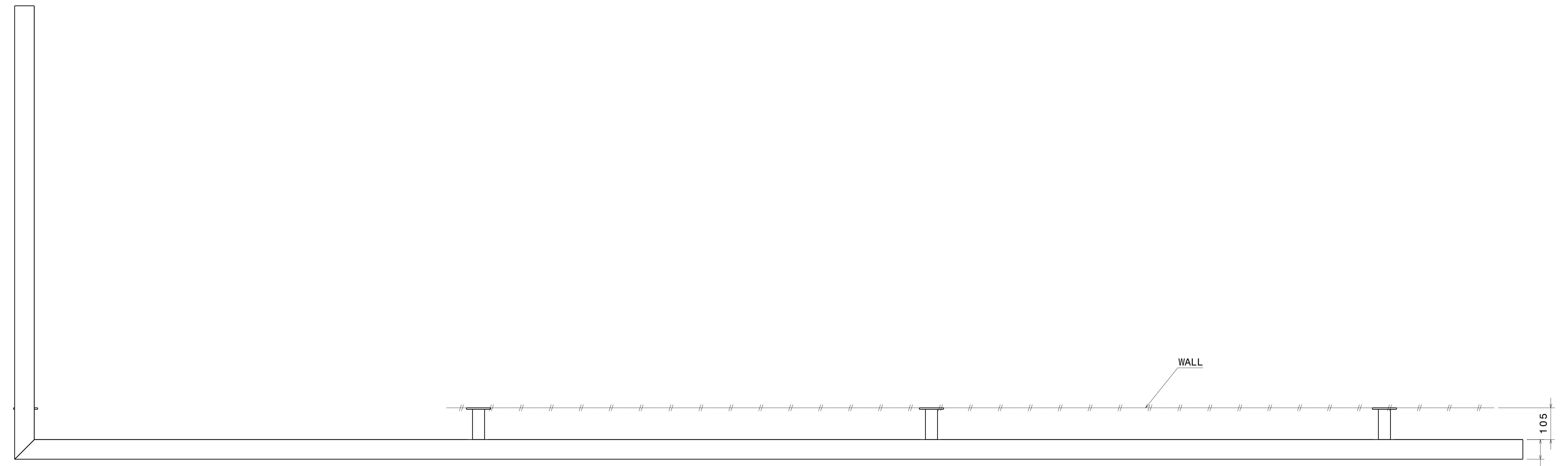

Top view
Scale: 3:20

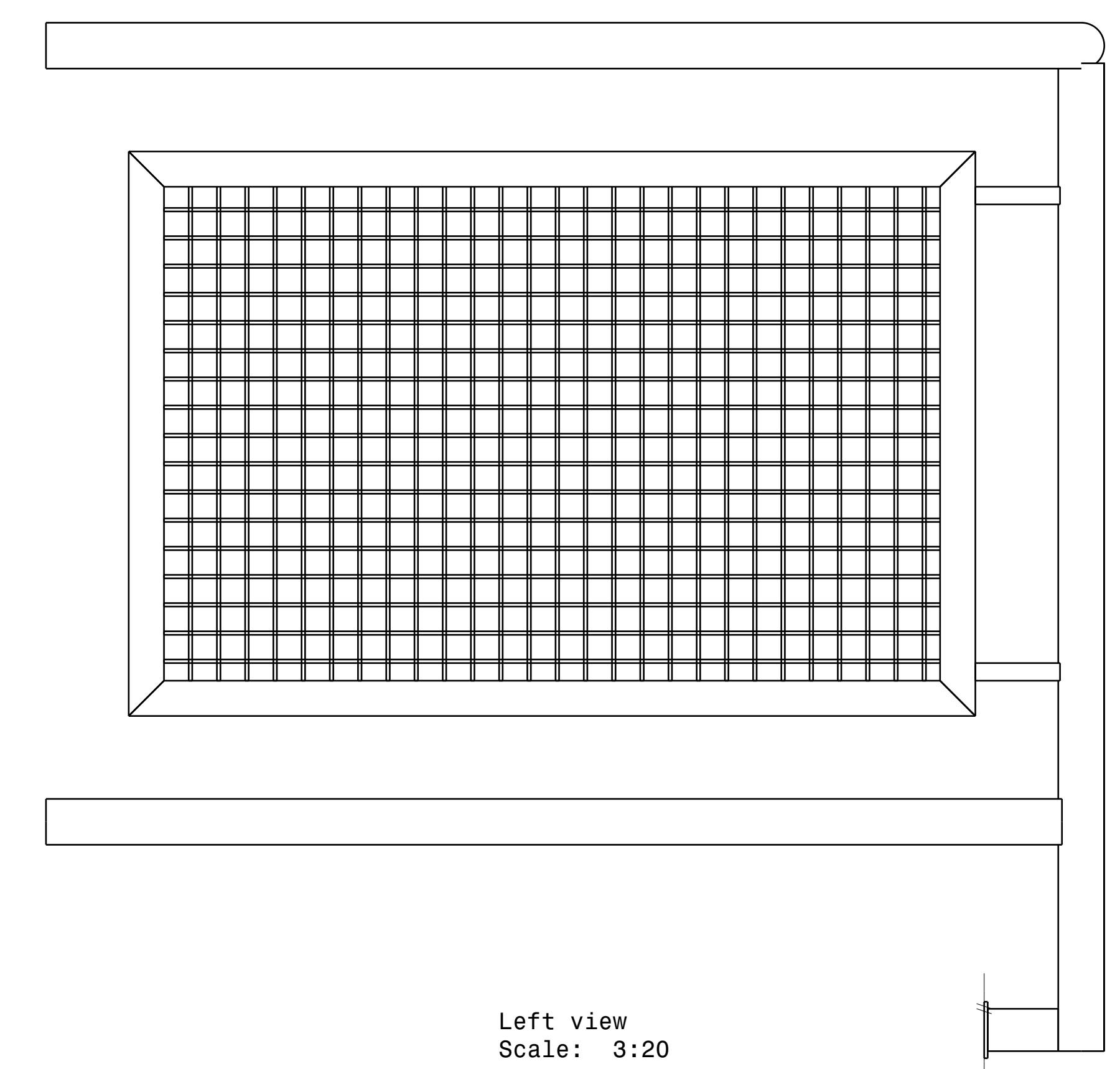

Left view
Scale: 3:20

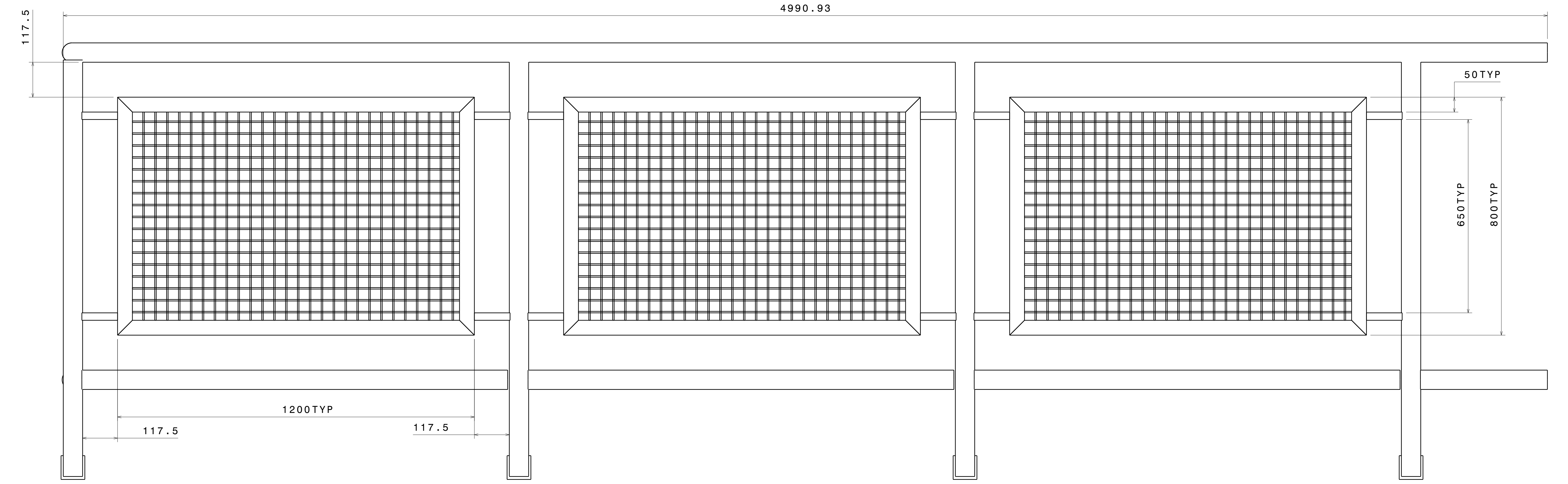

Front view
Scale: 3:20

This drawing is our property. It can't be reproduced or communicated without our written agreement.

APL APOLLO TUBES LTD. 

DRAWN BY	DATE
SB	29MAR2020
CHECKED BY	DATE
P2P Analysis & Solutions	29MAR2020
DESIGNED BY	DATE
P2P Analysis & Solutions	29MAR2020

DRAWING TITLE			
HAND RAIL 129			
SIZE	DRAWING NUMBER	REV	
A0	P2P HANDRAIL 000129	00	
SCALE	NONE	WEIGHT (kg)	XXX
			SHEET 2 OF 5

UNLESS OTHERWISE SPECIFIED DIMENSION ARE IN MM
VIEWS: THIRD ANGLE PROJECTION

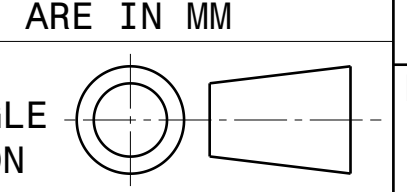

REV	DATE	DESCRIPTION
00	29MAR2020	INITIAL REVISION

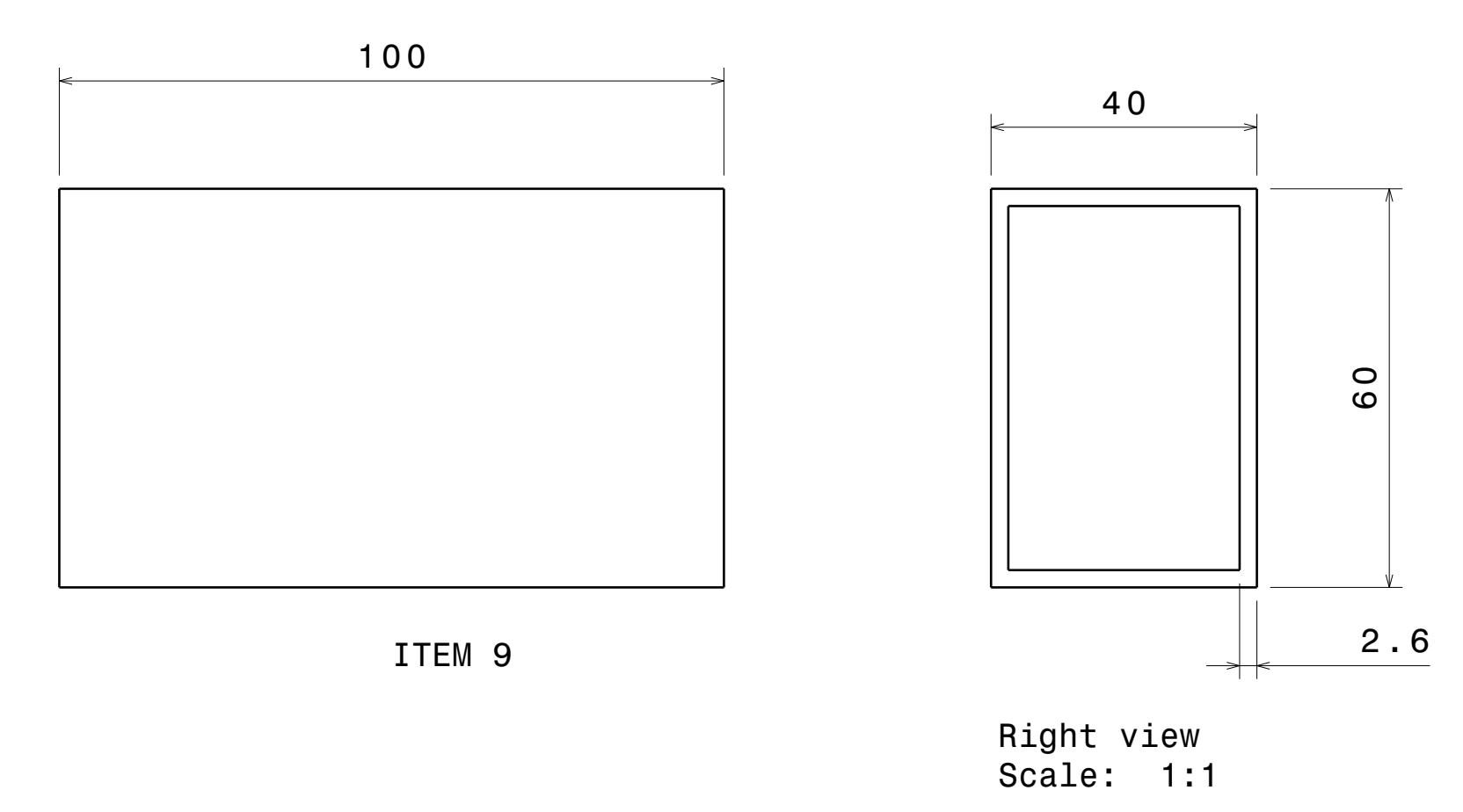
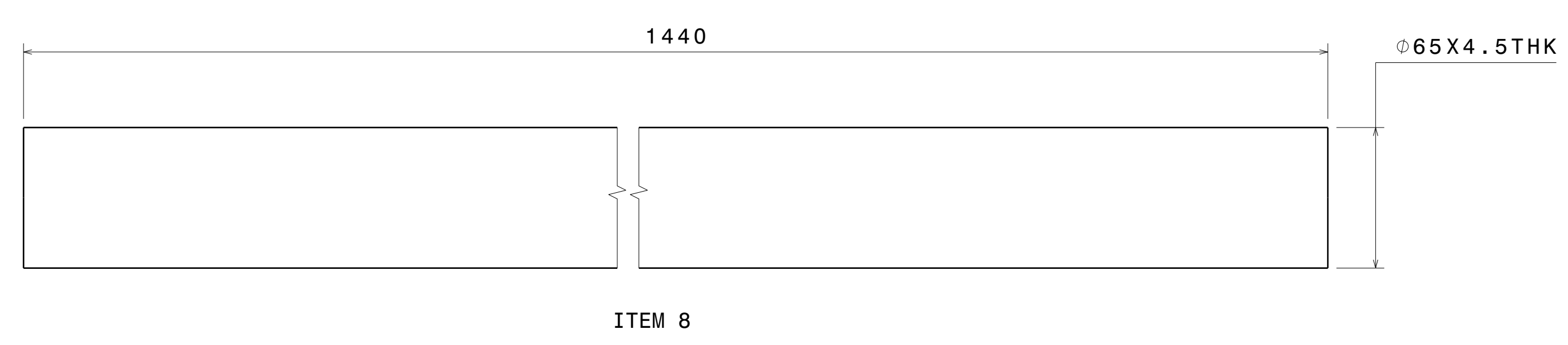
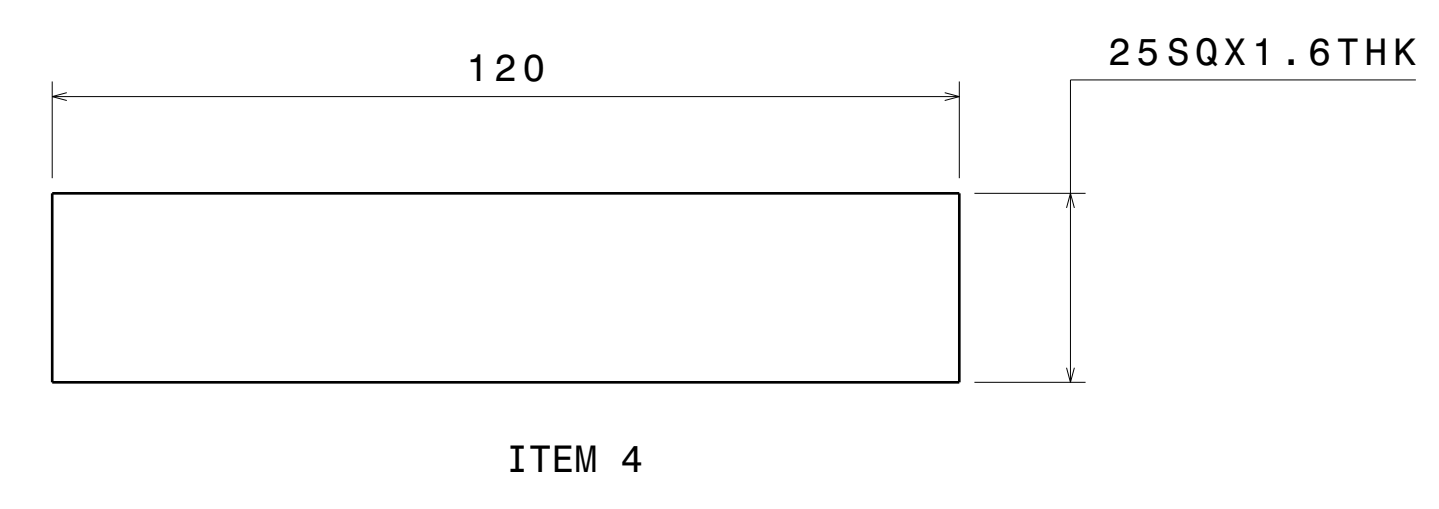
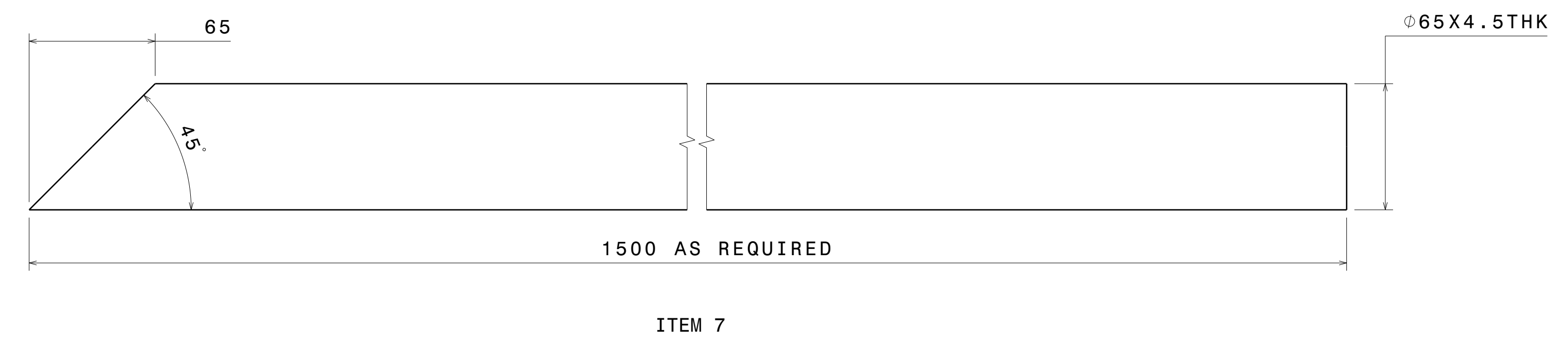
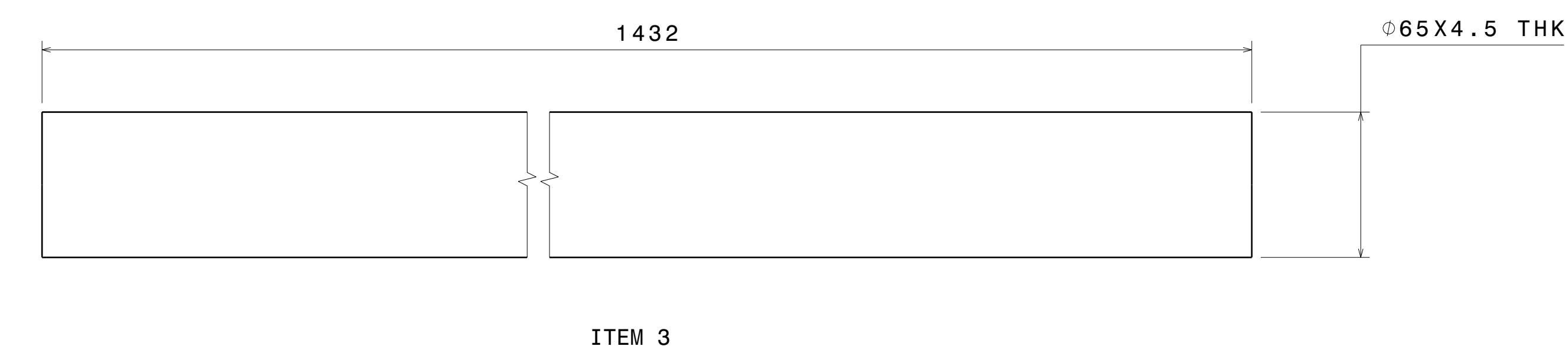
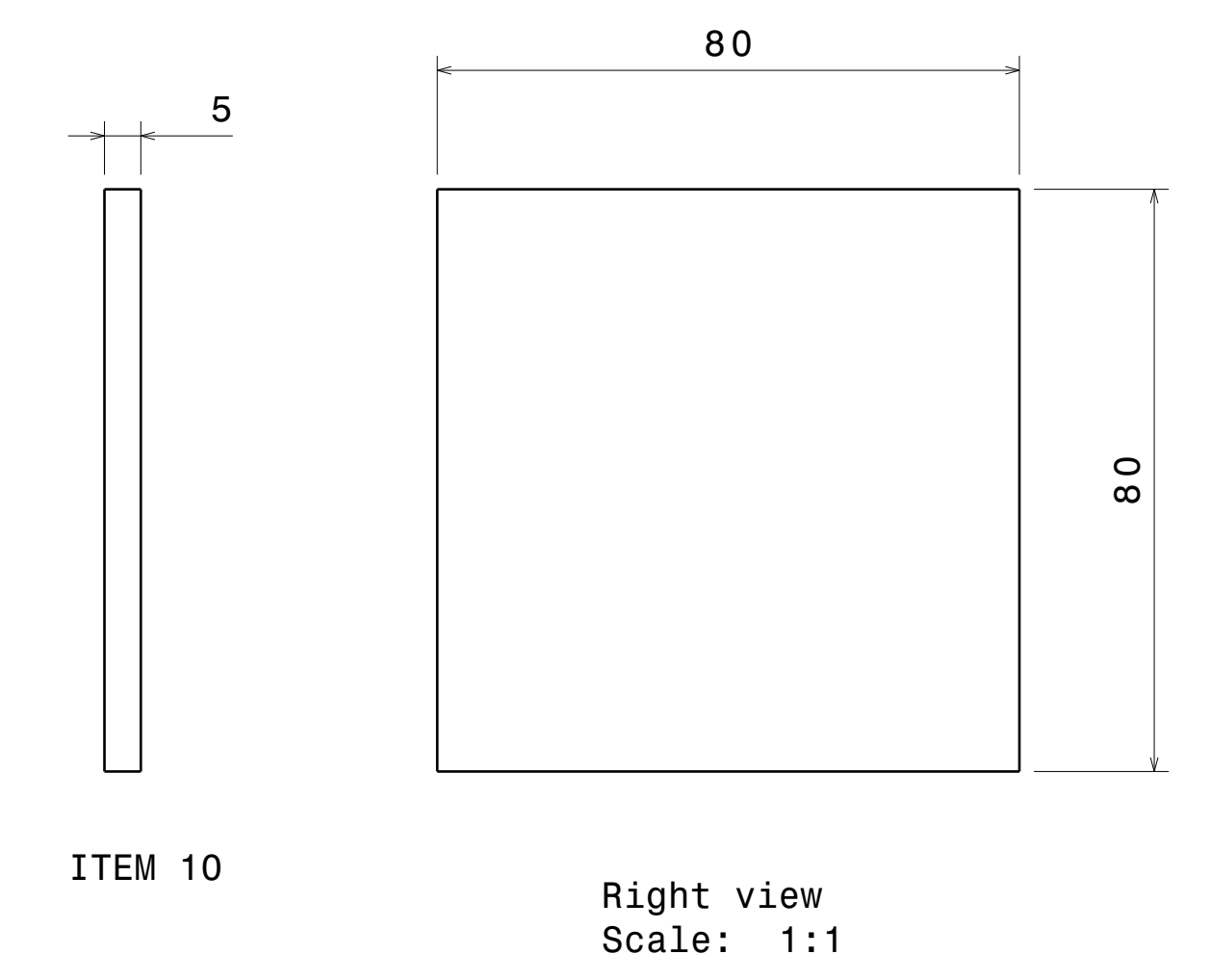
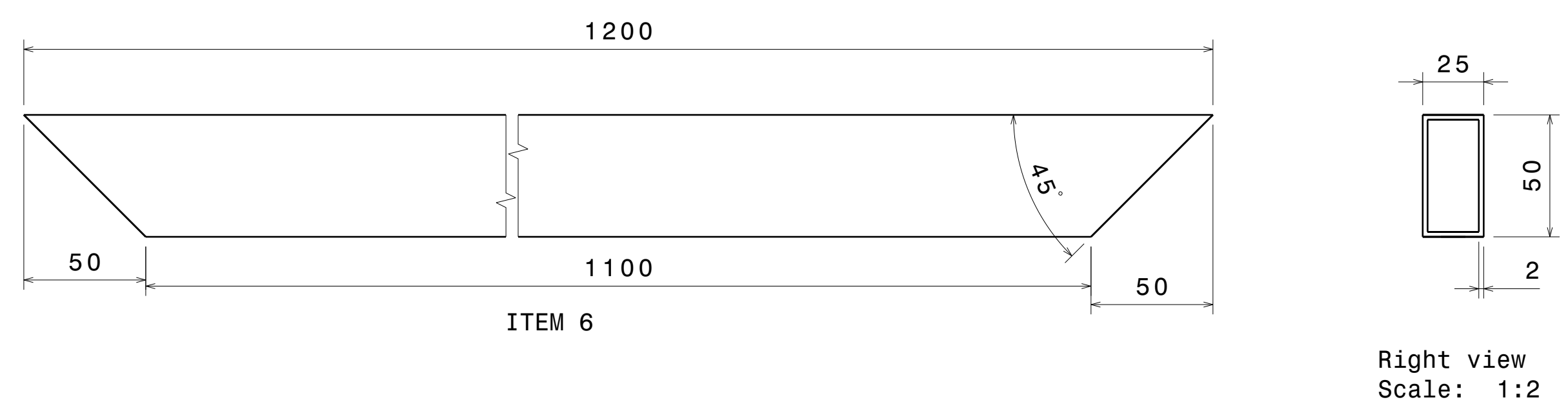
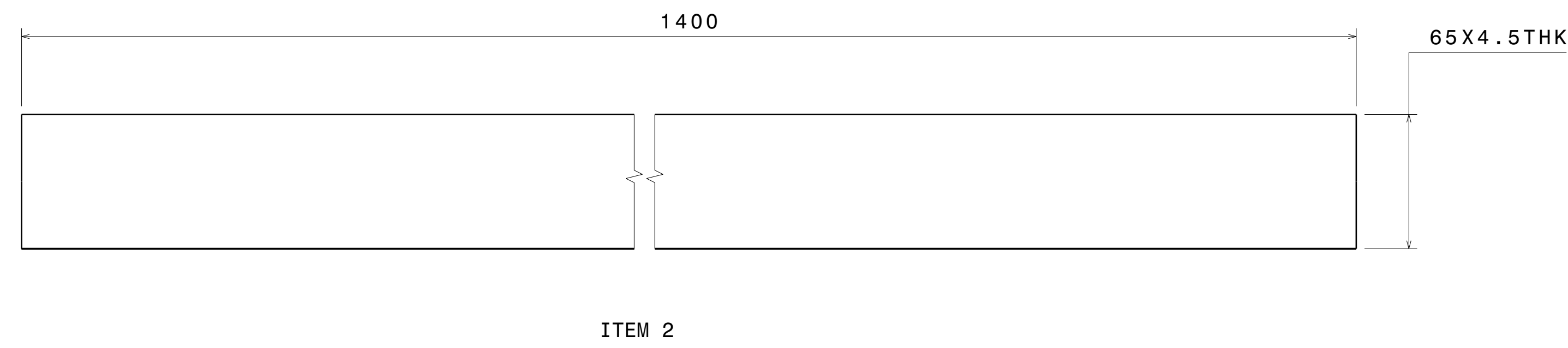
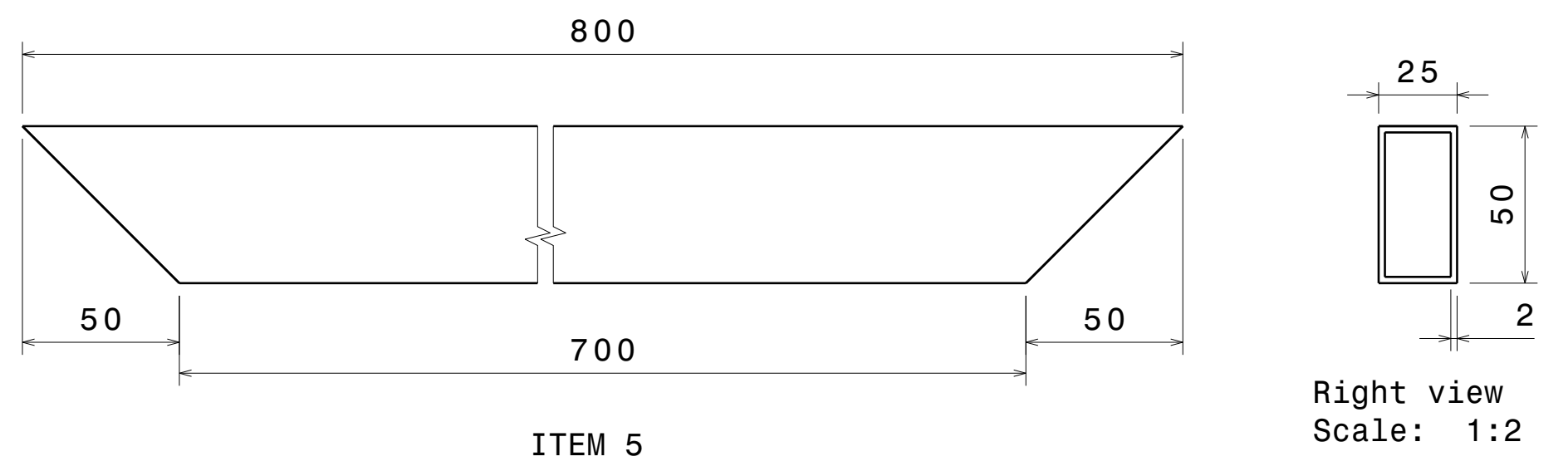
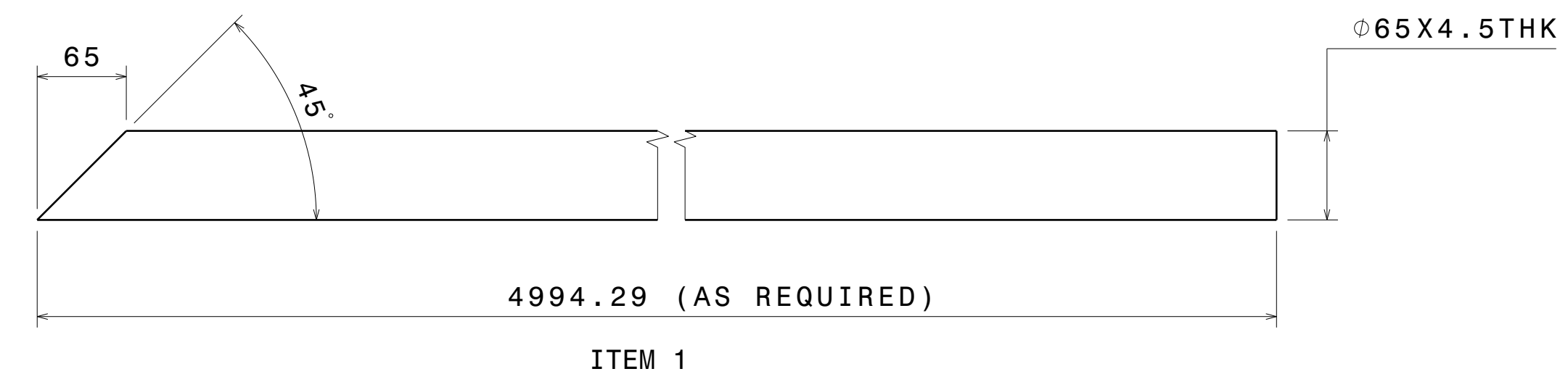

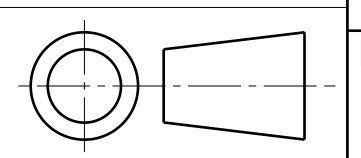
This drawing is our property. It can't be reproduced or communicated without our written agreement.		APL APOLLO TUBES LTD. 	
DRAWN BY SB		DATE 29MAR2020	
CHECKED BY P2P Analysis & Solutions		DATE 29MAR2020	
DESIGNED BY P2P Analysis & Solutions		DATE 29MAR2020	
DRAWING TITLE HAND RAIL 129		SIZE A0	DRAWING NUMBER P2P HANDRAIL 000129
UNLESS OTHERWISE SPECIFIED DIMENSION ARE IN MM		SCALE NONE	WEIGHT (kg) XXX
VIEWS: THIRD ANGLE PROJECTION 		REV 00	
		SHEET 3 OF 5	

UNLESS OTHERWISE SPECIFIED DIMENSION ARE IN MM

VIEWS:
THIRD ANGLE
PROJECTION 