

| REV/DATE | DESCRIPTION |
|----------------|------------------|
| 00 / 1/28/2020 | INITIAL REVISION |

- NOTES:
- (⊥) ALL VERTICAL SUPPORTS ARE PERPENDICULAR.
 - FLATNESS OF .5MM IS APPLIED BY DEFAULT.
 - ⊥ WELD BEAD OF 2MM RADIUS IS FOLLOWED.
 - ▽ SURFACE FINISH MEDIUM TO SMOOTH IS USED.
 - ALL TUBES ARE AS PER APL APOLLO STANDARD. CHANGES MAY EFFECT THE LOAD CAPACITY.
 - DUAL DIMENSIONS USED WITH BOTH METRIC AND INCH SYSTEM.
 - ALL HORIZONTAL AND VERTICAL TUBES ARE PERPENDICULAR TO EACH OTHER WITH ±1 DEG.
 - FINE WELDING IS REQUIRED AS PER MENTIONED DETAILS AND FINISHING.
 - HIGHER CURRENT WELDING MAY AFFECT THE BRITTLENESS OF MATERIAL WHICH LATER MAY RAISE TO WEAKENING OF STRUCTURE.

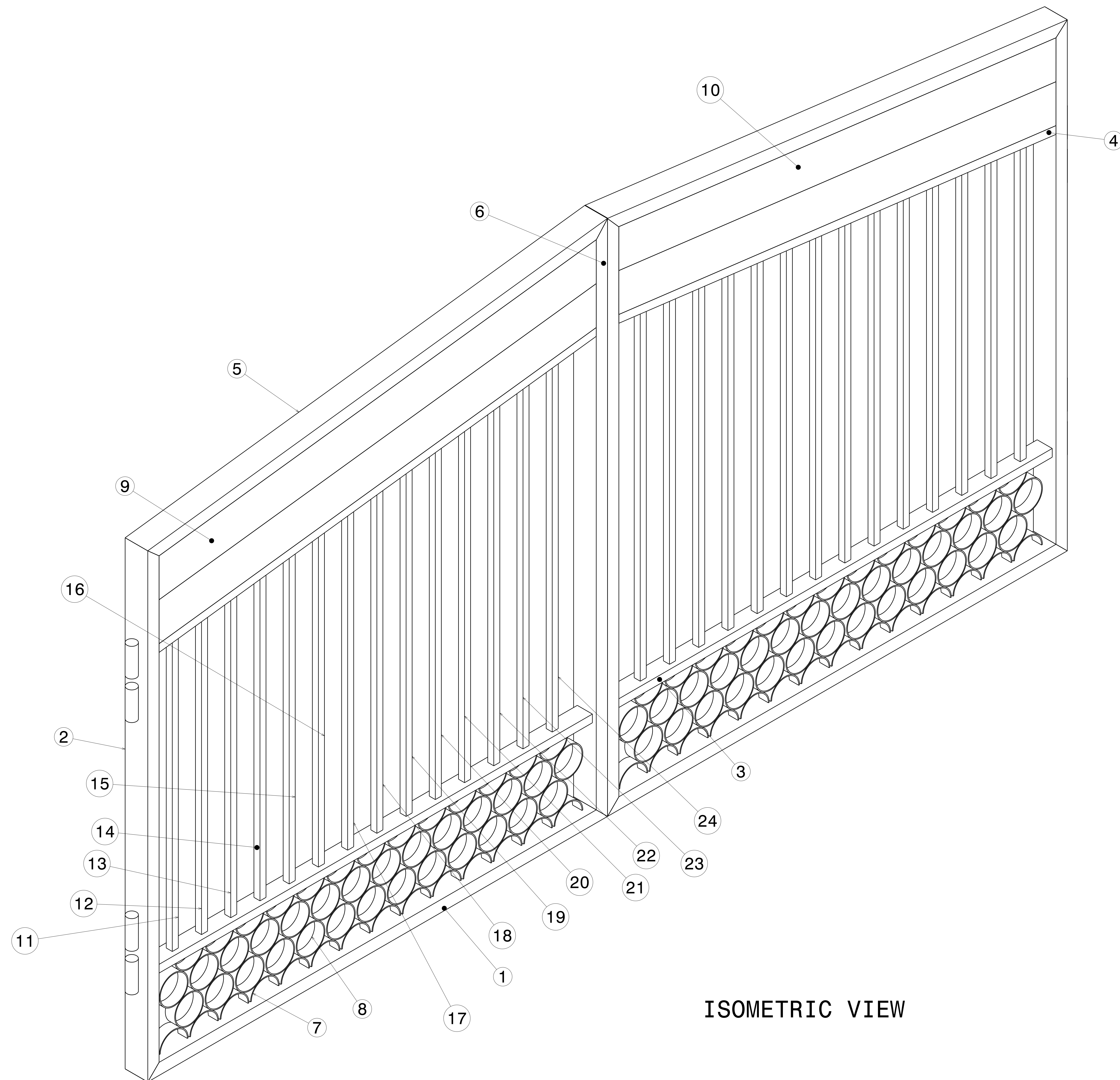

ISOMETRIC VIEW

| ITEM NO. | PART NUMBER | DESCRIPTION | QTY. |
|----------|--------------------------------|-------------------------|------|
| 25 | | HINGE | 8 |
| 24 | Gate 20 Square 1 - Middle 14 | 32 X 32 X 2 X 1725 | 2 |
| 23 | Gate 20 Square 1 - Middle 13 | 32 X 32 X 2 X 1706 | 2 |
| 22 | Gate 20 Square 1 - Middle 12 | 32 X 32 X 2 X 1686 | 2 |
| 21 | Gate 20 Square 1 - Middle 11 | 32 X 32 X 2 X 1667 | 2 |
| 20 | Gate 20 Square 1 - Middle 10 | 32 X 32 X 2 X 1647 | 2 |
| 19 | Gate 20 Square 1 - Middle 9 | 32 X 32 X 2 X 1628 | 2 |
| 18 | Gate 20 Square 1 - Middle 8 | 32 X 32 X 2 X 1608 | 2 |
| 17 | Gate 20 Square 1 - Middle 7 | 32 X 32 X 2 X 1589 | 2 |
| 16 | Gate 20 Square 1 - Middle 6 | 32 X 32 X 2 X 1570 | 2 |
| 15 | Gate 20 Square 1 - Middle 5 | 32 X 32 X 2 X 1550 | 2 |
| 14 | Gate 20 Square 1 - Middle 4 | 32 X 32 X 2 X 1530 | 2 |
| 13 | Gate 20 Square 1 - Middle 3 | 32 X 32 X 2 X 1510 | 2 |
| 12 | Gate 20 Square 1 - Middle 2 | 32 X 32 X 2 X 1491 | 2 |
| 11 | Gate 20 Square 1 - Middle 1 | 32 X 32 X 2 X 1470 | 2 |
| 10 | RIGHT - HALF RECTANGULAR PLATE | | 2 |
| 9 | LEFT - HALF RECTANGULAR PLATE | | 2 |
| 8 | CIRCULAR TUBE 1 | | 54 |
| 7 | SEMI CIRCULAR TUBE 1 | | 54 |
| 6 | Gate 20 Rectangular 2 | 120 X 60 X 3.2 X 2745 | 2 |
| 5 | Rect Tube 17 Frame 4 | 120 X 60 X 3.2 X 2460 | 2 |
| 4 | Rect Tube 17 Frame 6 | 80 X 40 X 2.6 X 2338 | 2 |
| 3 | Rect Tube 17 Frame 3 | 80 X 40 X 2.6 X 2318 | 2 |
| 2 | Rect Tube 17 Frame 2 | 120 X 60 X 3.2 X 2438.4 | 2 |
| 1 | Rect Tube 17 Frame 1 | 120 X 60 X 3.2 X 2438.4 | 2 |

This drawing is our property. It can't be reproduced or communicated without our written agreement.

APL APOLLO TUBES LTD.

DRAWING TITLE: GATE 20

SIZE: A0 DRAWING NUMBER: P2P APL_00020 REV: 00

SCALE: NONE WEIGHT (kg): 505 SHEET: 1

UNLESS OTHERWISE SPECIFIED DIMENSION ARE IN MM VIEWS: THIRD ANGLE PROJECTION

DESIGNED BY: P2P Analysis & Solutions DATE: 1/28/2020

CHECKED BY: P2P Analysis & Solutions DATE: 1/28/2020

DRAWN BY: SB DATE: 1/28/2020

| REV | DATE | DESCRIPTION |
|-----|-----------|------------------|
| 00 | 1/28/2020 | INITIAL REVISION |

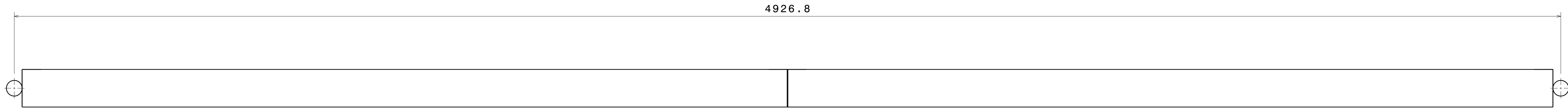

Top view
Scale: 3:20

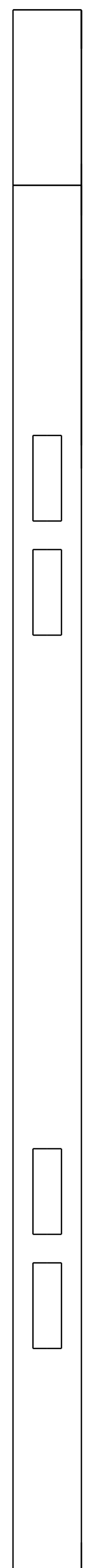

Left view
Scale: 3:20

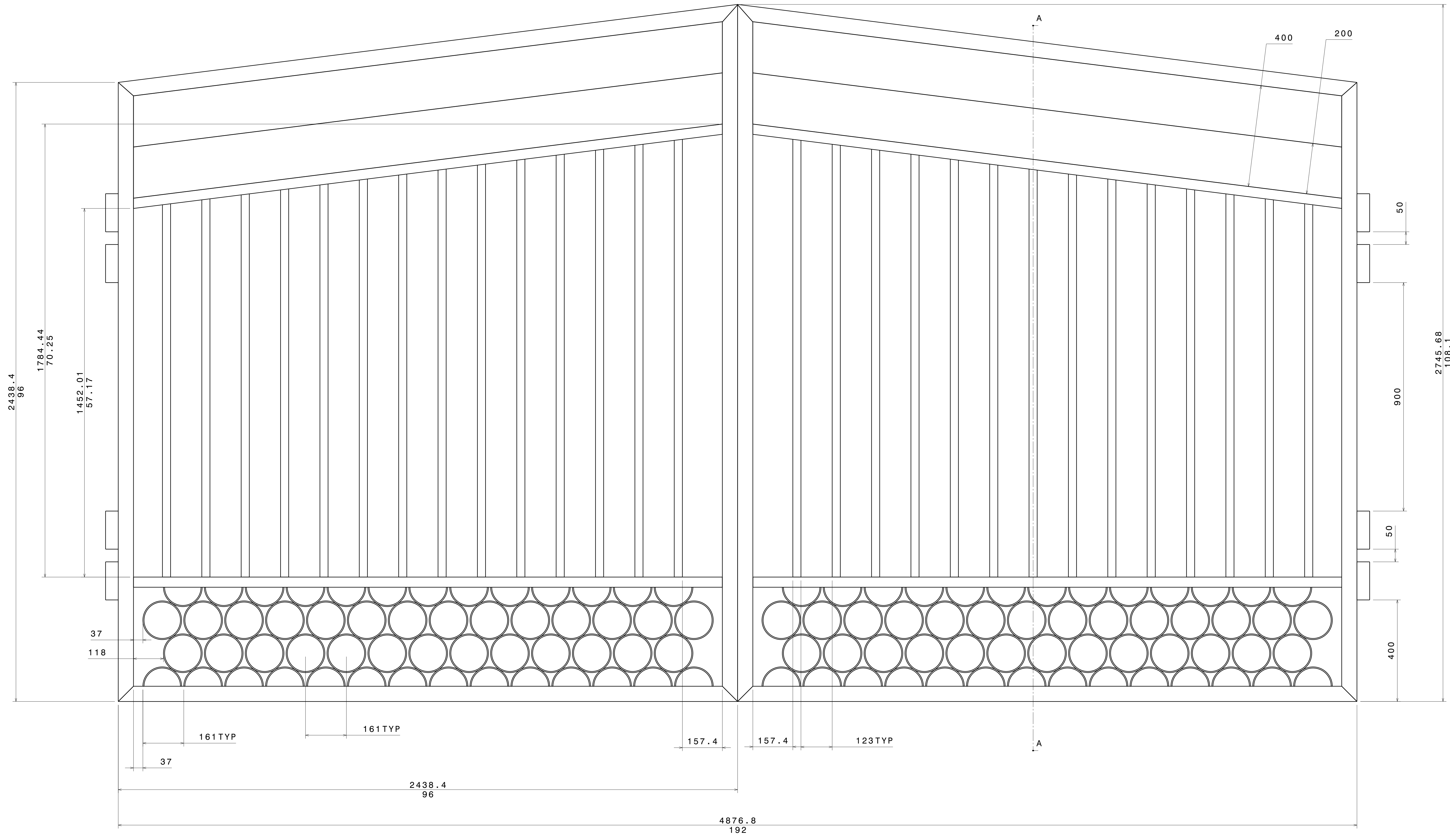

Front view
Scale: 3:20

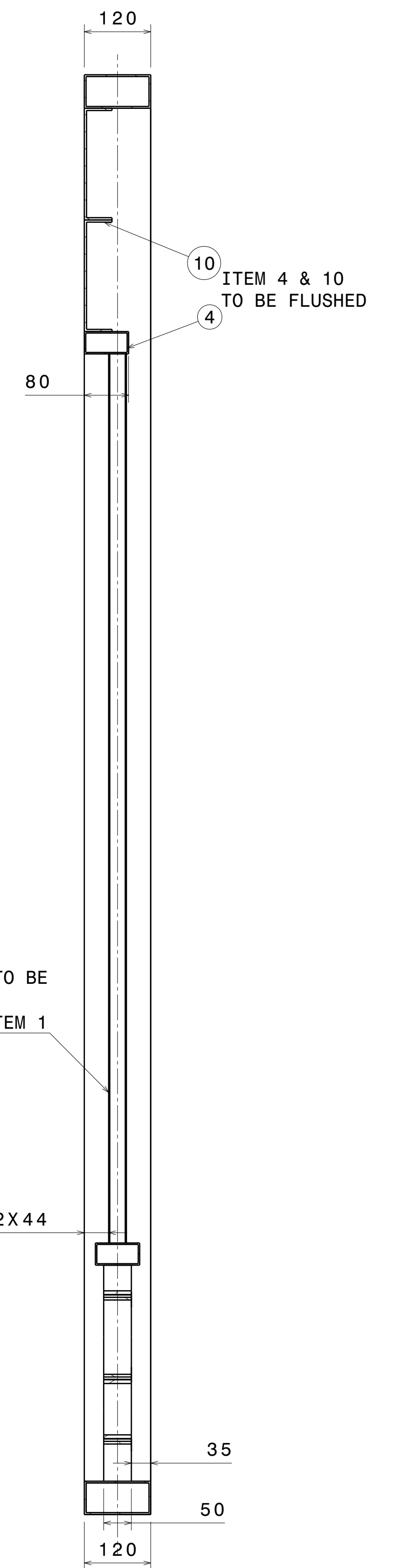



Section view A-A
Scale: 3:20

ITEM 11 TO 24 TO BE SYMMETRICALLY ALIGNED WITH ITEM 1

ITEM 4 & 10 TO BE FLUSHED

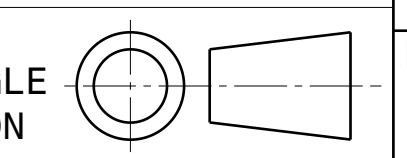
UNLESS OTHERWISE SPECIFIED DIMENSION ARE IN MM VIEWS: THIRD ANGLE PROJECTION



| | | | |
|---|---------------------------------|---|--|
| This drawing is our property. It can't be reproduced or communicated without our written agreement. | | APL APOLLO TUBES LTD.  | |
| DRAWN BY SB | | DATE 1/28/2020 | |
| CHECKED BY P2P Analysis & Solutions | | DATE 1/28/2020 | |
| DESIGNED BY P2P Analysis & Solutions | | DATE 1/28/2020 | |
| SIZE A0 | DRAWING NUMBER P2P APL 00020 | REV 00 | |
| SCALE NONE | WEIGHT (kg) 472 | SHEET 2 | |

DRAWING TITLE
GATE 20

| REV | DATE | DESCRIPTION |
|-----|-----------|------------------|
| 00 | 1/28/2020 | INITIAL REVISION |

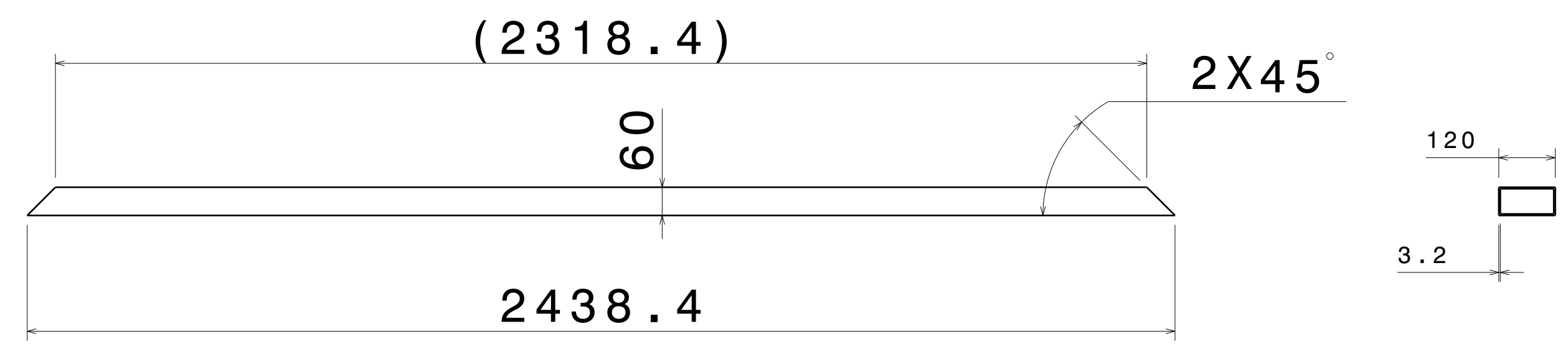

ITEM 1, QTY 2

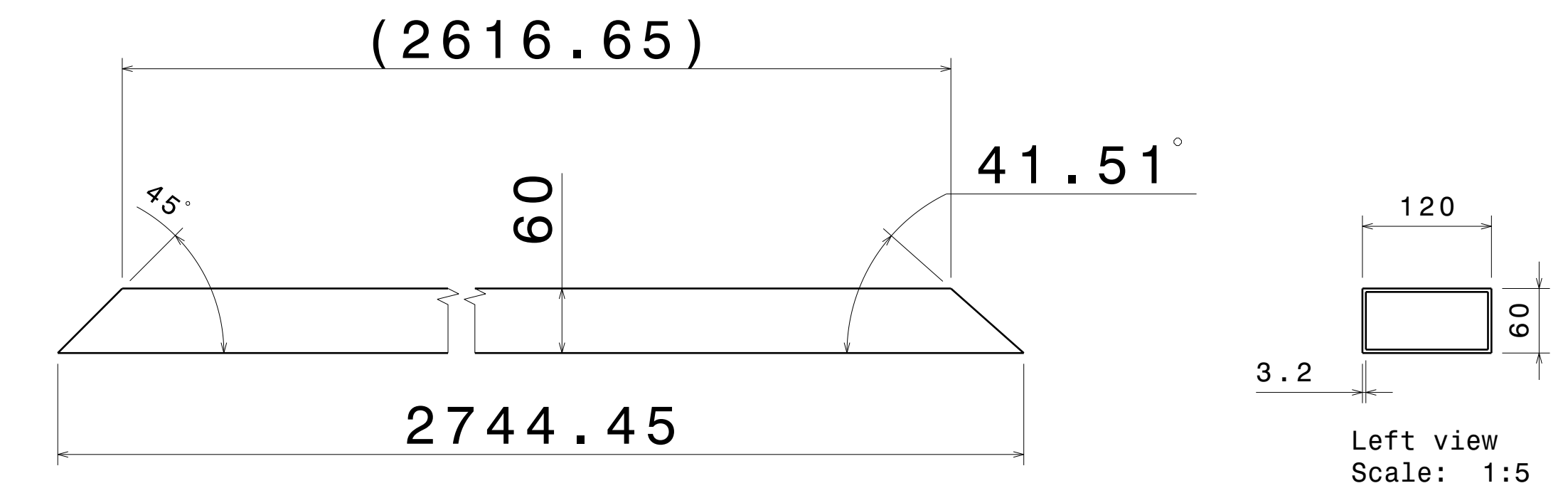

ITEM 6, QTY 2

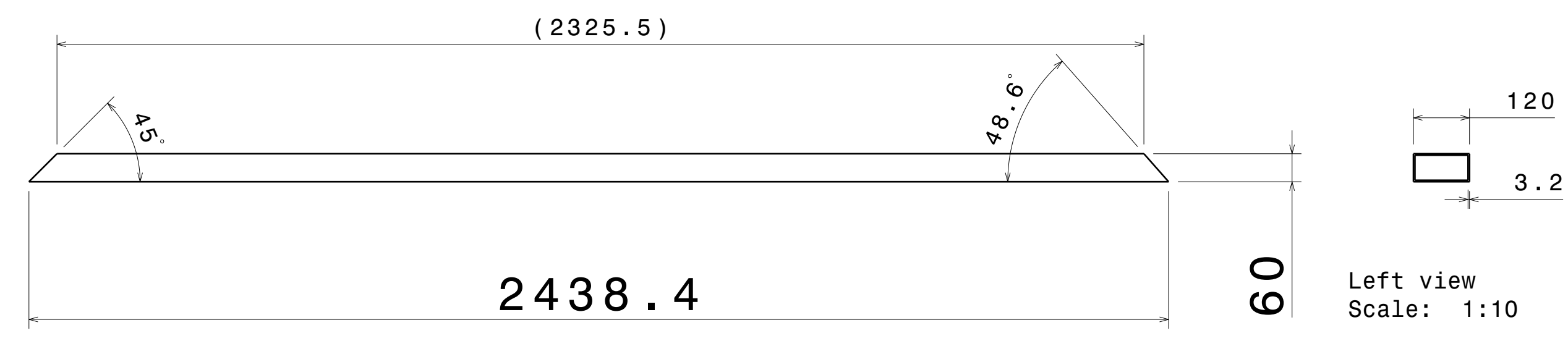

ITEM 2, QTY 2

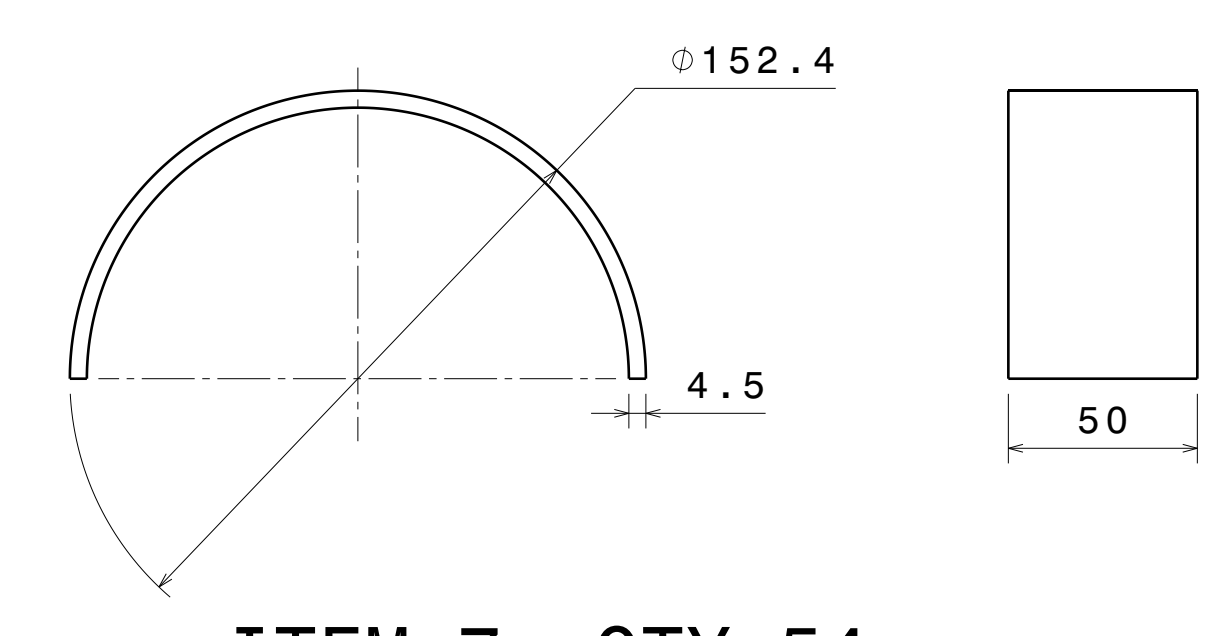

ITEM 7, QTY 54

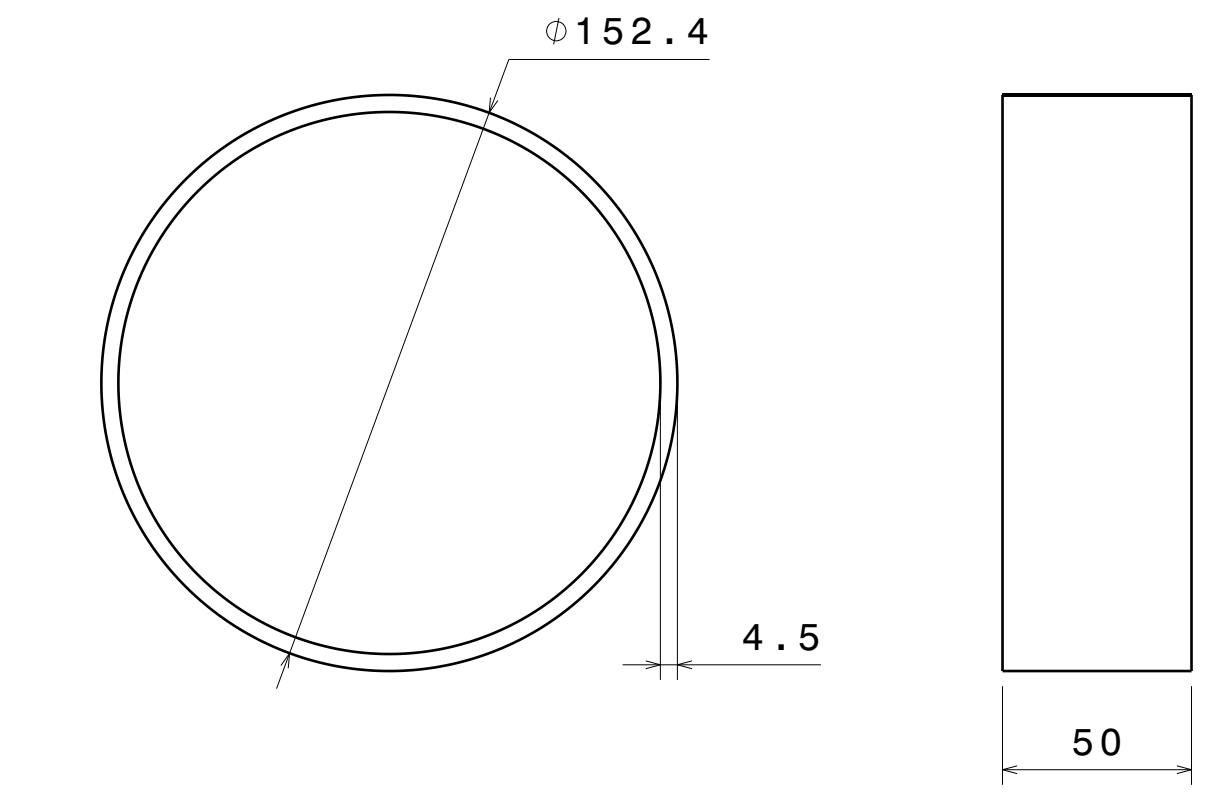

ITEM 8, QTY 54

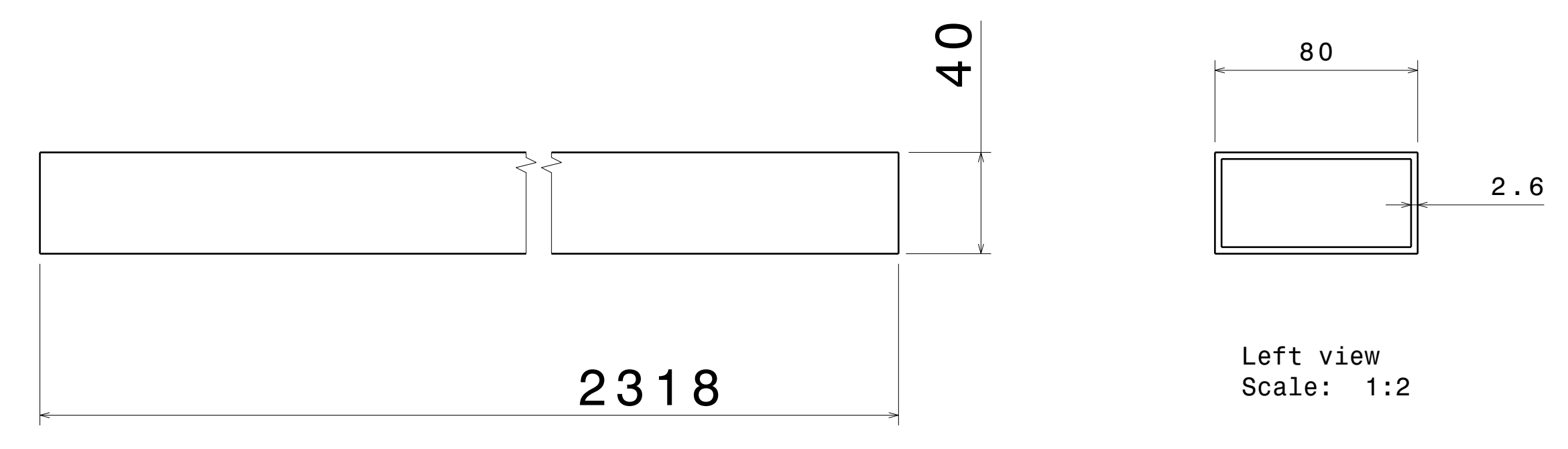

ITEM 3, QTY 2

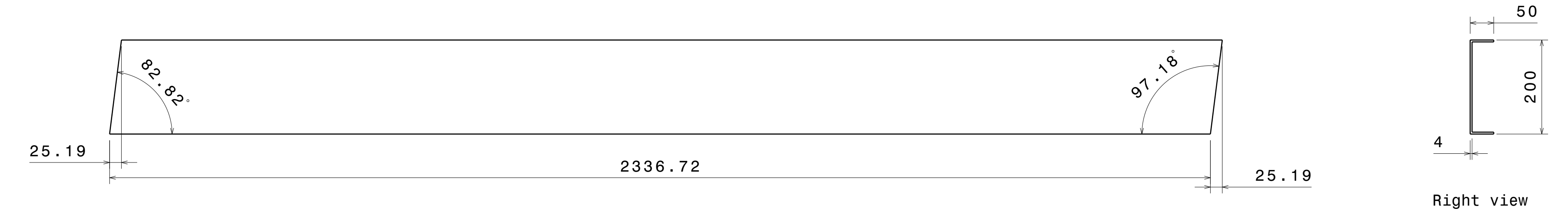

ITEM 9, QTY 2
LEFT SIDE

TO MANUFACTURE: TAKE RECTANGULAR HOLLOW CROSS SECTION OF 200 X 100 X 4 WITH LENGTH 2340. THEN CUT IT HALF ON WIDTH (100 MM) SIDE TO MAKE IT 2. AND WELD AS NEEDED.

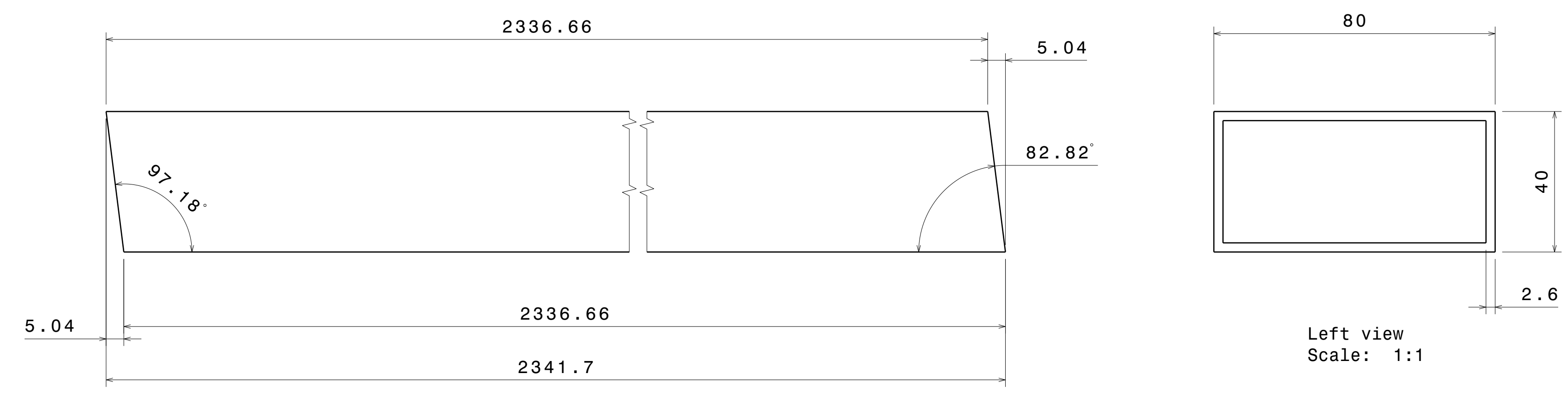

ITEM 4, QTY 2

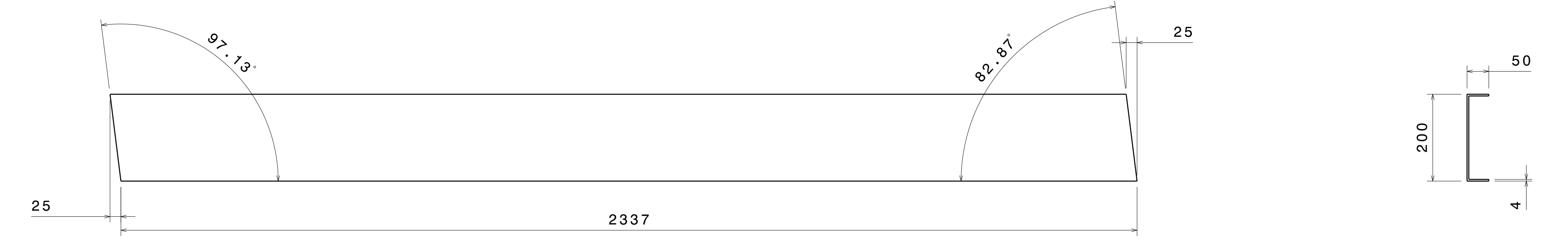

ITEM 10, QTY 2
RIGHT SIDE

TO MANUFACTURE: TAKE RECTANGULAR HOLLOW CROSS SECTION OF 200 X 100 X 4 WITH LENGTH 2340. THEN CUT IT HALF ON WIDTH (100 MM) SIDE TO MAKE IT 2. AND WELD AS NEEDED.

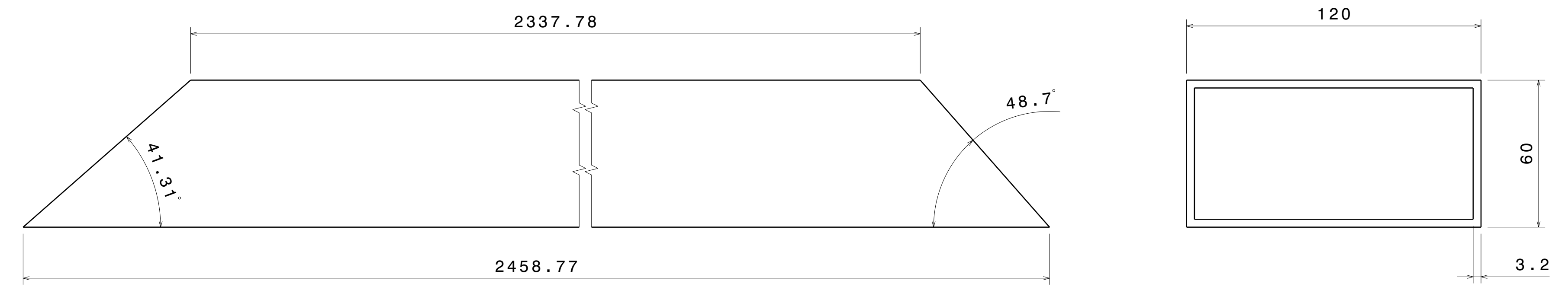

ITEM 5, QTY 2

UNLESS OTHERWISE SPECIFIED DIMENSION ARE IN MM VIEWS: THIRD ANGLE PROJECTION

| | | | |
|---|--|-----------------------|-------------------------------|
| This drawing is our property. It can't be reproduced or communicated without our written agreement. | | APL APOLLO TUBES LTD. | |
| DRAWN BY: SB | | DATE: 1/28/2020 | |
| CHECKED BY: P2P Analysis & Solutions | | DATE: 1/28/2020 | |
| DESIGNED BY: P2P Analysis & Solutions | | DATE: 1/28/2020 | |
| DRAWING TITLE: GATE 20 | | SIZE: A0 | DRAWING NUMBER: P2P APL 00020 |
| SCALE: NONE | | WEIGHT (kg): XXX | SHEET: 3 |

| REV | DATE | DESCRIPTION |
|-----|-----------|------------------|
| 00 | 1/28/2020 | INITIAL REVISION |

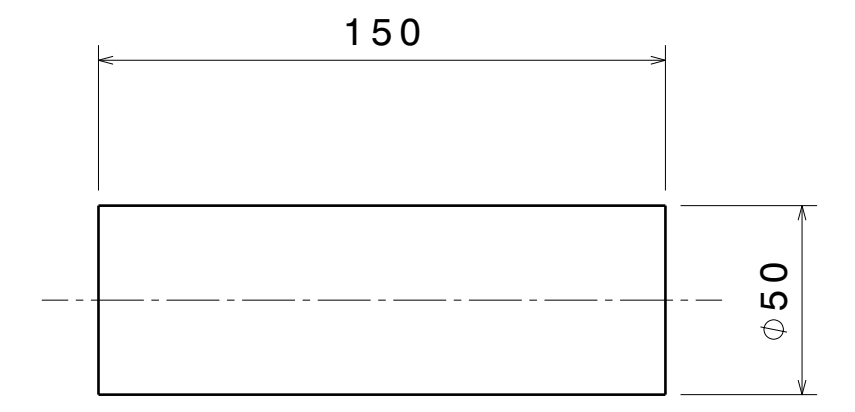
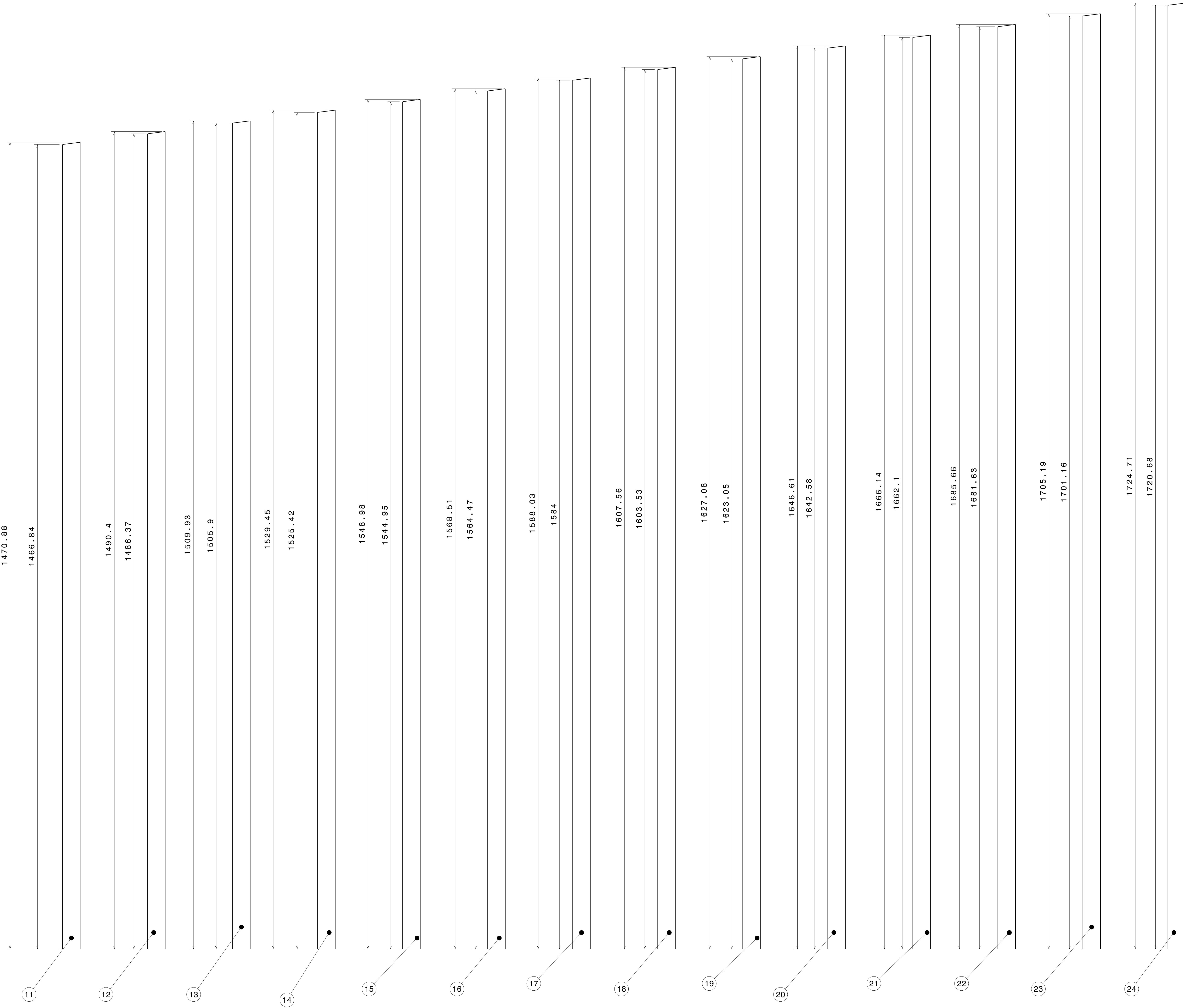

ITEM 25, QTY 8, HINGE
DIMENSIONS ARE FOR REFERENCE ONLY

ITEM 11 TO 24, SAME CROSS SECTION 32 X 32 X 2

| | | | |
|---|---------------------------------|---|--|
| This drawing is our property. It can't be reproduced or communicated without our written agreement. | | APL APOLLO TUBES LTD.  | |
| DRAWN BY SB | | DATE 1/28/2020 | |
| CHECKED BY P2P Analysis & Solutions | | DATE 1/28/2020 | |
| DESIGNED BY P2P Analysis & Solutions | | DATE 1/28/2020 | |
| SIZE A0 | DRAWING NUMBER P2P APL_00020 | REV 00 | |
| SCALE NONE | WEIGHT (kg) XXX | SHEET 4 | |

UNLESS OTHERWISE SPECIFIED
DIMENSION ARE IN MM
VIEWS:
THIRD ANGLE PROJECTION

