

REV/DATE	DESCRIPTION
00 / 1/28/2020	INITIAL REVISION

- NOTES:
- (⊥) ALL VERTICAL SUPPORTS ARE PERPENDICULAR.
 - FLATNESS OF .5MM IS APPLIED BY DEFAULT.
 - ⊥ WELD BEAD OF 2MM RADIUS IS FOLLOWED.
 - ▽ SURFACE FINISH MEDIUM TO SMOOTH IS USED.
 - ALL TUBES ARE AS PER APL APOLLO STANDARD. CHANGES MAY EFFECT THE LOAD CAPACITY.
 - DUAL DIMENSIONS USED WITH BOTH METRIC AND INCH SYSTEM.
 - ALL HORIZONTAL AND VERTICAL TUBES ARE PERPENDICULAR TO EACH OTHER WITH ±1 DEG.
 - FINE WELDING IS REQUIRED AS PER MENTIONED DETAILS AND FINISHING.
 - HIGHER CURRENT WELDING MAY AFFECT THE BRITTLENESS OF MATERIAL WHICH LATER MAY RAISE TO WEAKENING OF STRUCTURE.

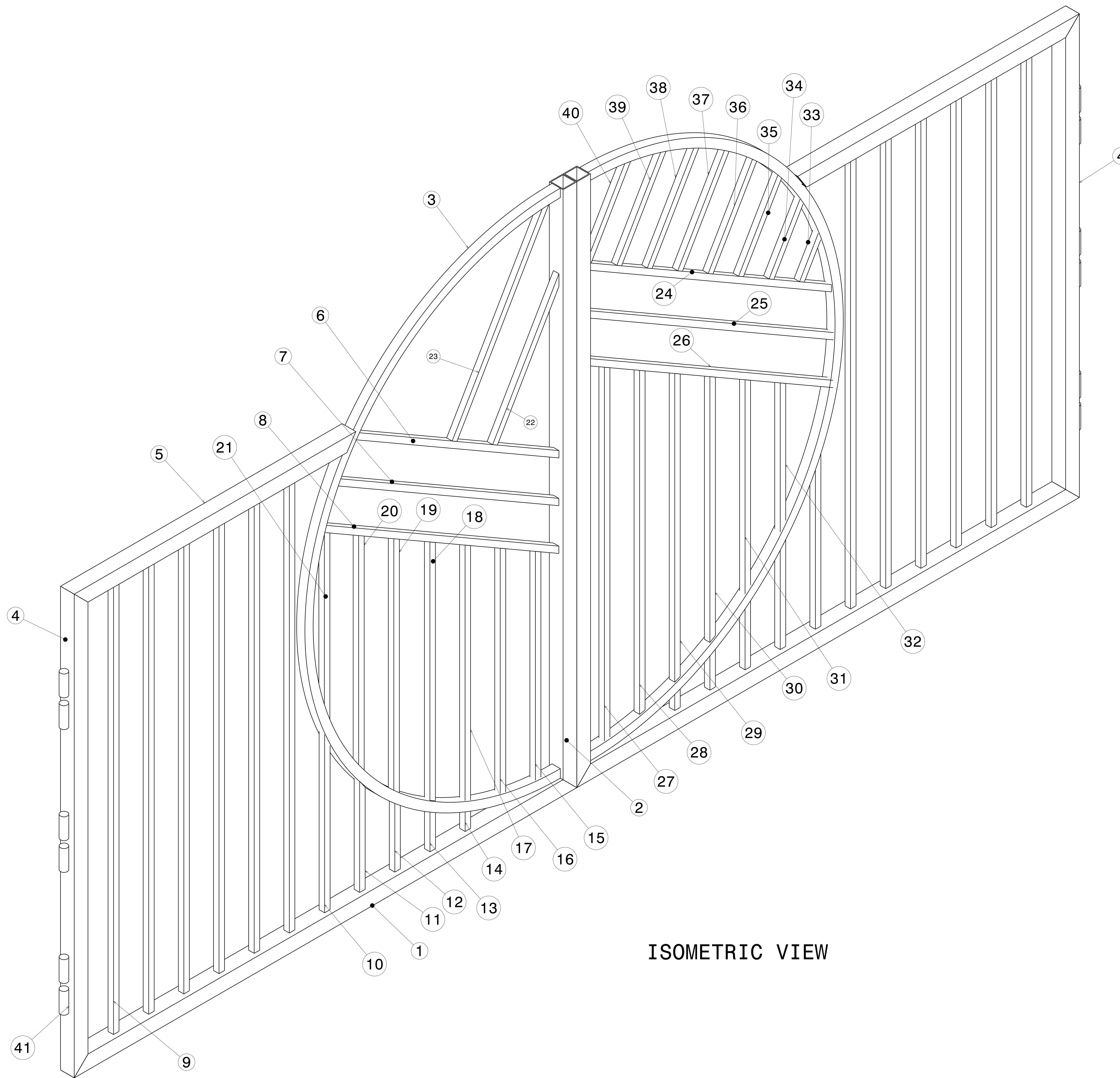

ISOMETRIC VIEW

ITEM NO	PART DESCRIPTION	DESCRIPTION	QTY.
41	HINGE		12
40	Sq tube 19 Frame 41	(40 X 40 X 3.2 X 583)	1
39	Sq tube 19 Frame 40	(40 X 40 X 3.2 X 660)	1
38	Sq tube 19 Frame 39	(40 X 40 X 3.2 X 687)	1
37	Sq tube 19 Frame 38	(40 X 40 X 3.2 X 690)	1
36	Sq tube 19 Frame 37	(40 X 40 X 3.2 X 648)	1
35	Sq tube 19 Frame 36	(40 X 40 X 3.2 X 573)	1
34	Sq tube 19 Frame 35	(40 X 40 X 3.2 X 451)	1
33	Sq tube 19 Frame 34	(40 X 40 X 3.2 X 274)	1
32	Sq tube 19 Frame 33	(40 X 40 X 3.2 X 781.7)	1
31	Sq tube 19 Frame 32	(40 X 40 X 3.2 X 1221.12)	1
30	Sq tube 19 Frame 31	(40 X 40 X 3.2 X 1576.72)	1
29	Sq tube 19 Frame 30	(40 X 40 X 3.2 X 1861.2)	1
28	Sq tube 19 Frame 29	(40 X 40 X 3.2 X 2102)	1
27	Sq tube 19 Frame 28	(40 X 40 X 3.2 X 2298)	1
26	Sq tube 19 Frame 27	(40 X 40 X 3.2 X 2095.5)	1
25	Sq tube 19 Frame 26	(40 X 40 X 3.2 X 2100.58)	1
24	Sq tube 19 Frame 25	(40 X 40 X 3.2 X 2082.8)	1
23	Sq tube 19 Frame 24	(40 X 40 X 3.2 X 1350)	1
22	Sq tube 19 Frame 23	(40 X 40 X 3.2 X 965.2)	1
21	Sq tube 19 Frame 22	(40 X 40 X 3.2 X 1214)	1
20	Sq tube 19 Frame 21	(40 X 40 X 3.2 X 1520)	1
19	Sq tube 19 Frame 20	(40 X 40 X 3.2 X 1623)	1
18	Sq tube 19 Frame 19	(40 X 40 X 3.2 X 1615.4)	1
17	Sq tube 19 Frame 18	(40 X 40 X 3.2 X 1626.24)	1
16	Sq tube 19 Frame 17	(40 X 40 X 3.2 X 1556.44)	1
15	Sq tube 19 Frame 16	(40 X 40 X 3.2 X 1443)	1
14	Sq Tube 19 Frame 14	(40 X 40 X 3.2 X 167)	2
13	Sq Tube 19 Frame 13	(40 X 40 X 3.2 X 304.8)	2
12	Sq Tube 19 Frame 12	(40 X 40 X 3.2 X 512)	2
11	Sq Tube 19 Frame 11	(40 X 40 X 3.2 X 810)	2
10	Sq Tube 19 Frame 10	(40 X 40 X 3.2 X 1175)	2
9	Sq Tube 19 Frame 9	(40 X 40 X 3.2 X 2848)	12
8	Sq Tube 19 Frame 8	(40 X 40 X 3.2 X 1994)	1
7	Sq Tube 19 Frame 7	(40 X 40 X 3.2 X 1868.8)	1
6	Sq Tube 19 Frame 6	(40 X 40 X 3.2 X 1713)	1
5	Sq Tube 19 Frame 4	(100 X 100 X 6 X 2120.9)	2
4	Sq Tube 19 Frame 3	(100 X 100 X 6 X 3048)	2
3	Sq tube 19 Circular Frame 1	(60 X 60 X 4 X R1798.8)	2
2	Sq Tube 19 Frame 2	(100 X 100 X 6 X 3817.6)	2
1	Sq Tube 19 Frame 1	(100 X 100 X 6 X 3657.6)	2

UNLESS OTHERWISE SPECIFIED DIMENSION ARE IN MM
 VIEWS: THIRD ANGLE PROJECTION

APL APOLLO TUBES LTD.

DRAWING TITLE: GATE 19

SIZE: A0 DRAWING NUMBER: P2P APL 00019 REV: 00

SCALE: NONE WEIGHT (kg): 830 SHEET: 1

REV	DATE	DESCRIPTION
00	1/28/2020	INITIAL REVISION

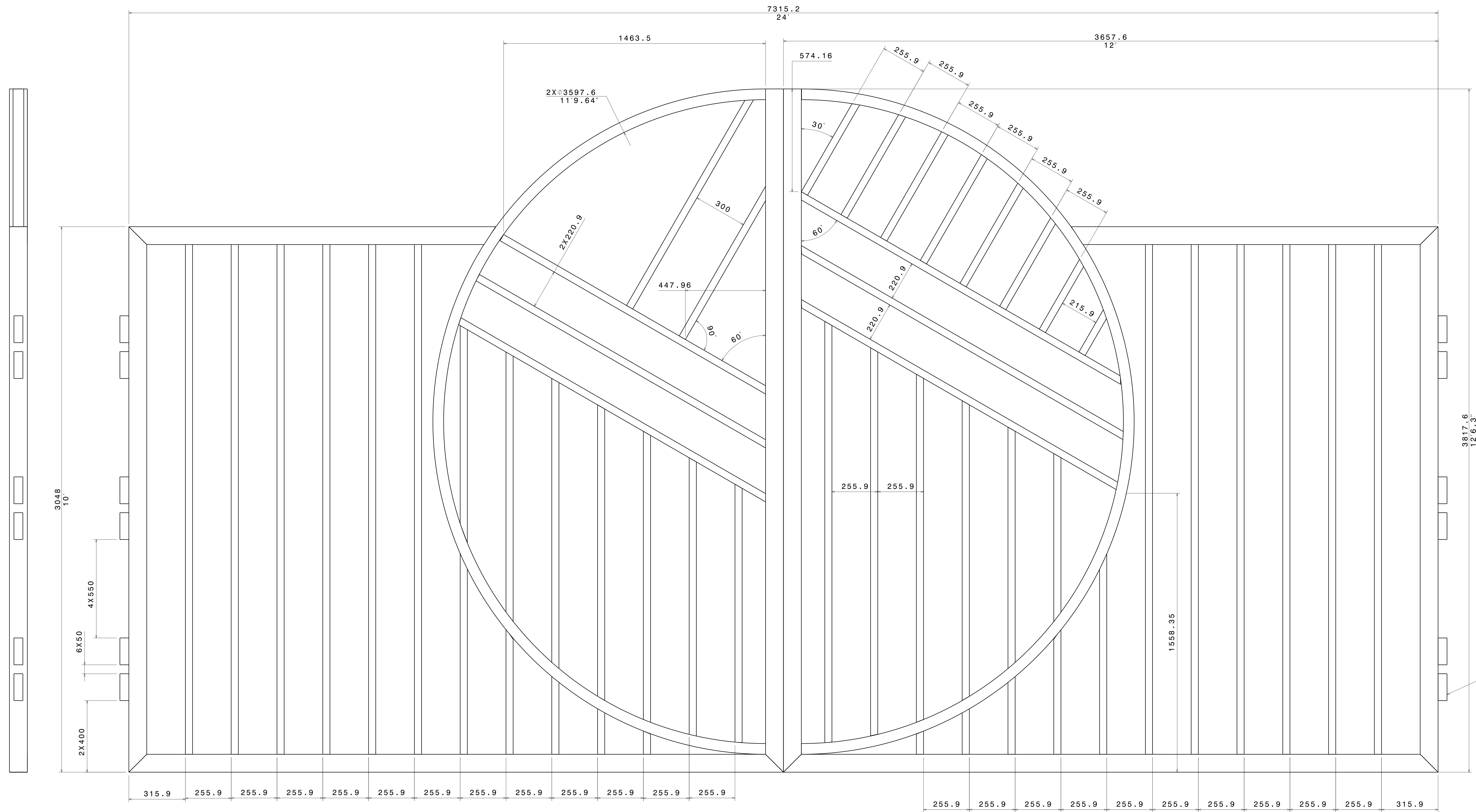

FRONT VIEW

HINGES HERE FOR REFERENCE ONLY THIS CAN BE PURCHASED AS STANDARD COMPONENT

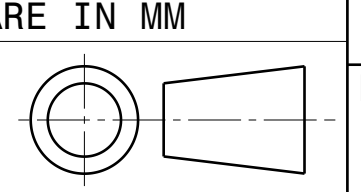
This drawing is our property. It can't be reproduced or communicated without our written agreement.		APL APOLLO TUBES LTD. 	
DRAWN BY SB		DRAWING TITLE GATE 19	
CHECKED BY P2P Analysis & Solutions		SIZE A0	
DESIGNED BY P2P Analysis & Solutions		DRAWING NUMBER P2P APL_00019	
UNLESS OTHERWISE SPECIFIED DIMENSION ARE IN MM VIEWS: THIRD ANGLE PROJECTION 		SCALE NONE	
DATE 02/10/2020		WEIGHT (kg) XXX	
DATE 02/10/2020		SHEET 2	
DATE 02/10/2020		REV 00	

REV	DATE	DESCRIPTION
A	1/28/2020	INITIAL REVISION

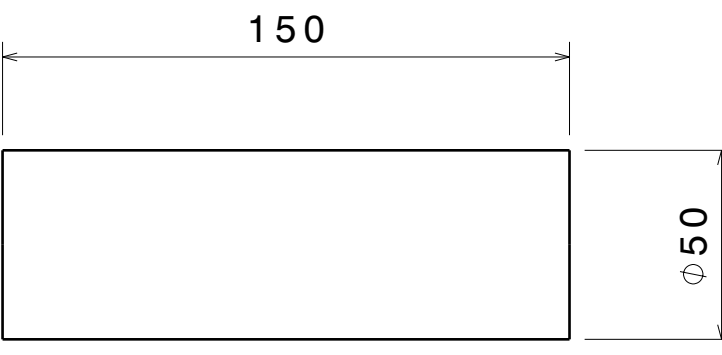
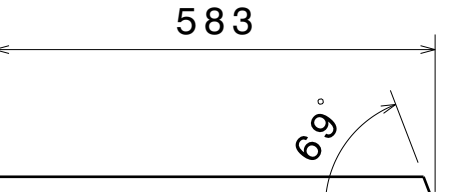
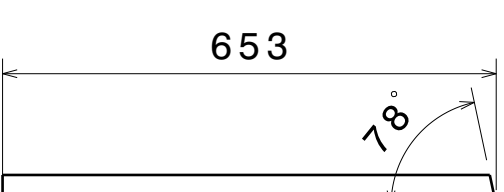
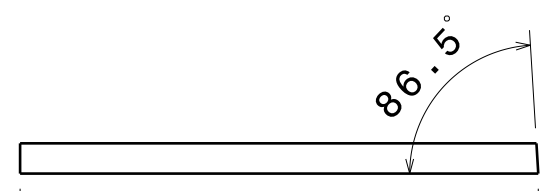
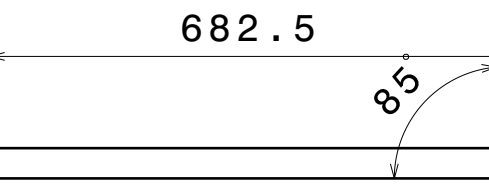
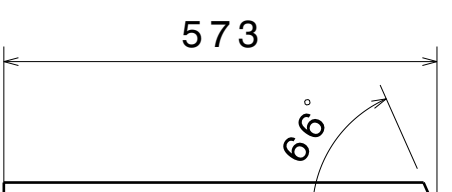
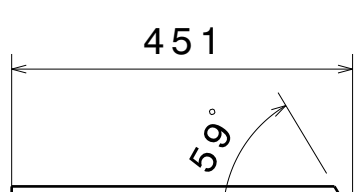
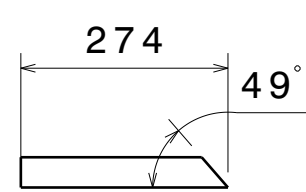
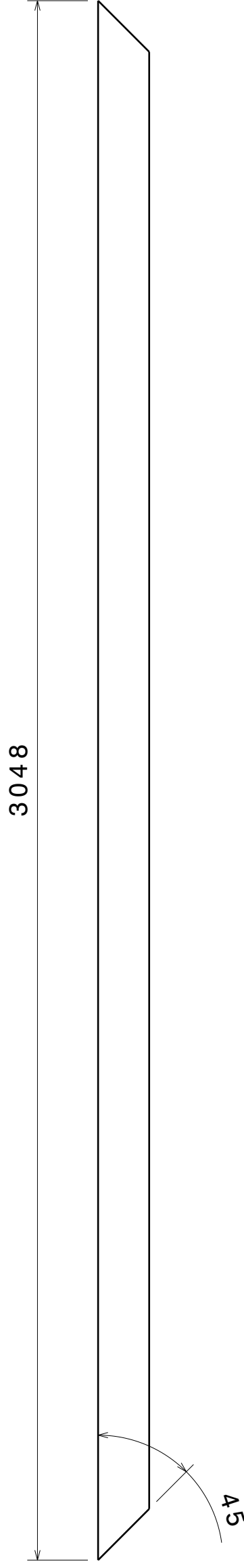
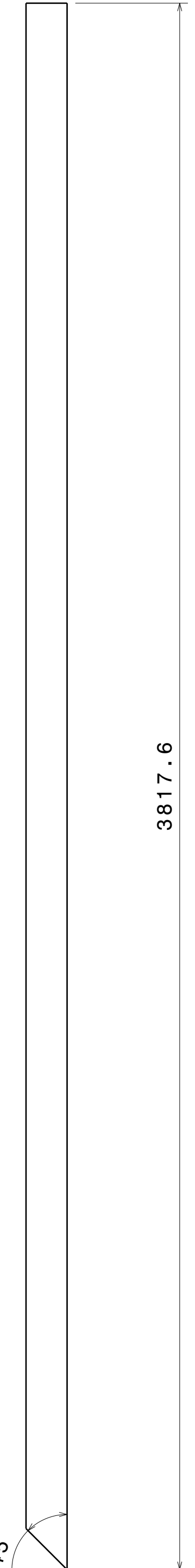
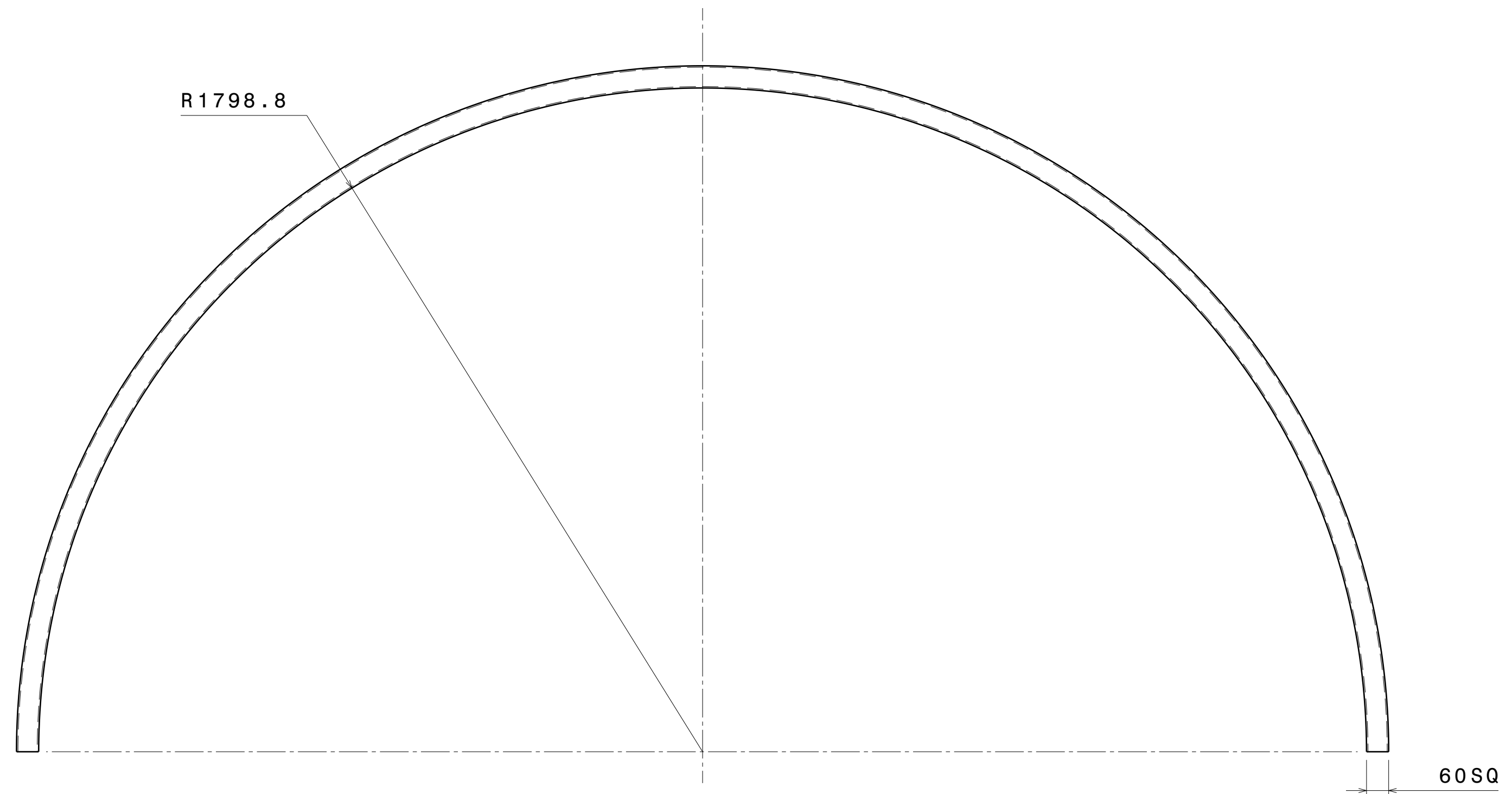
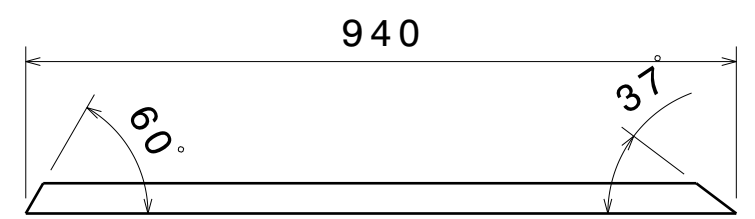
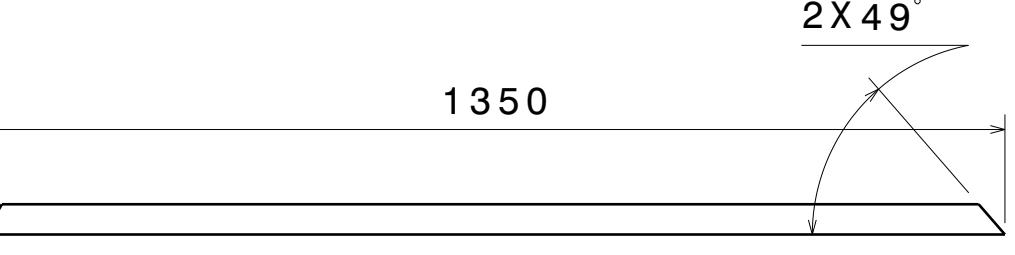
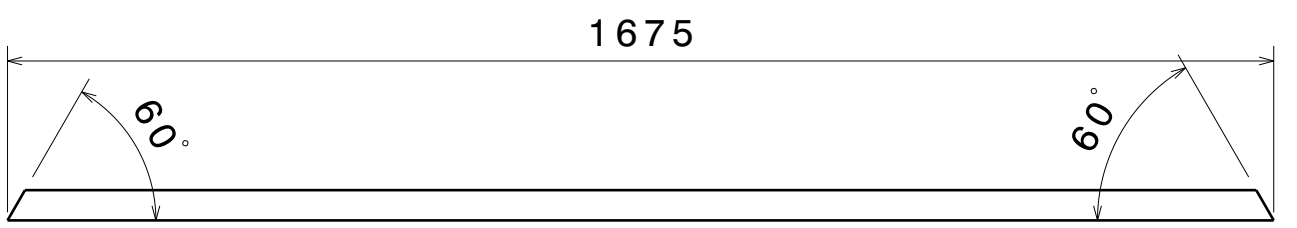
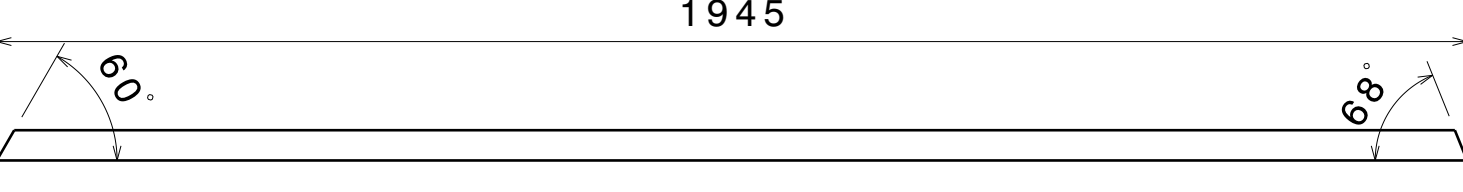
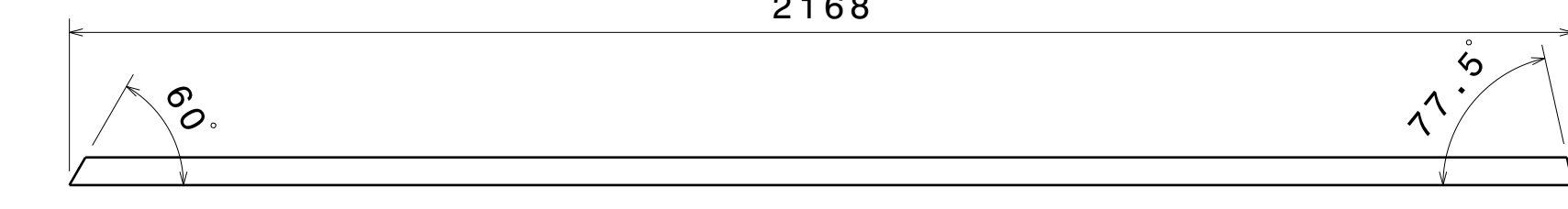
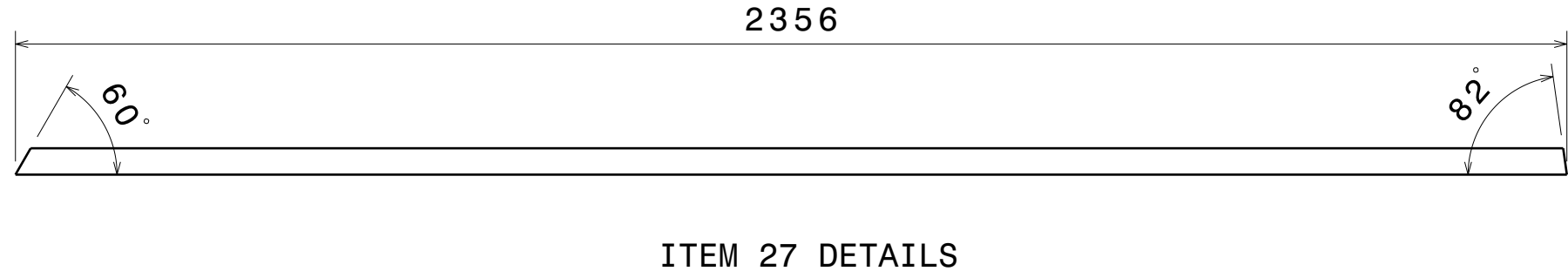
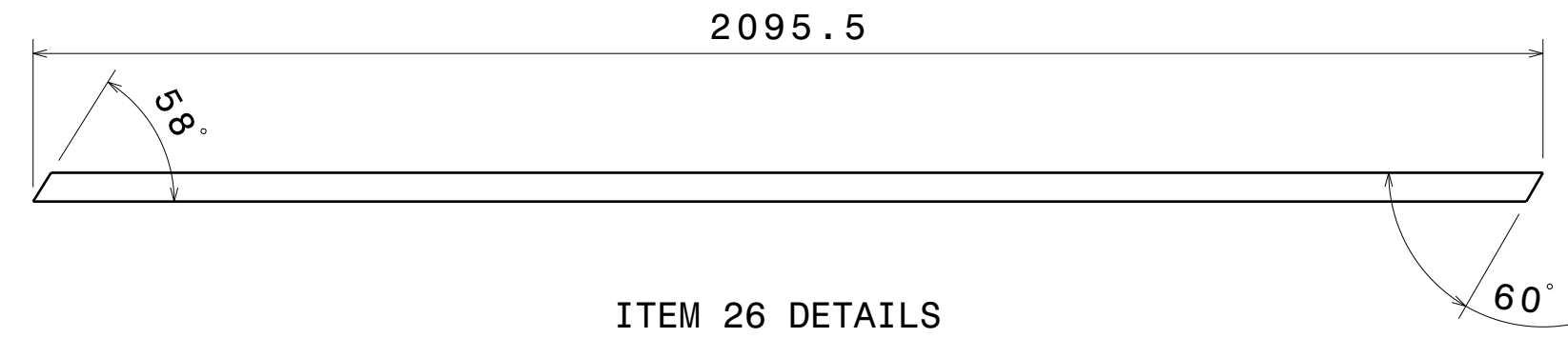
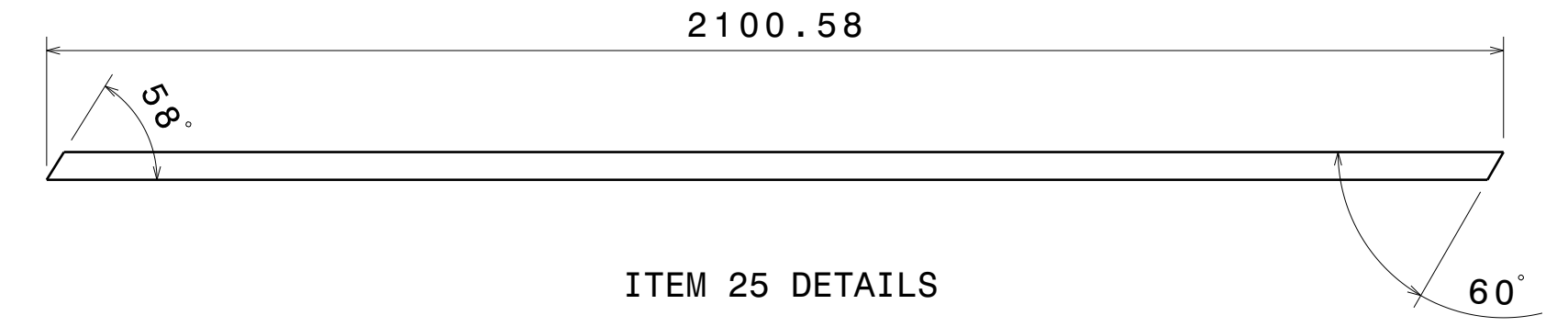
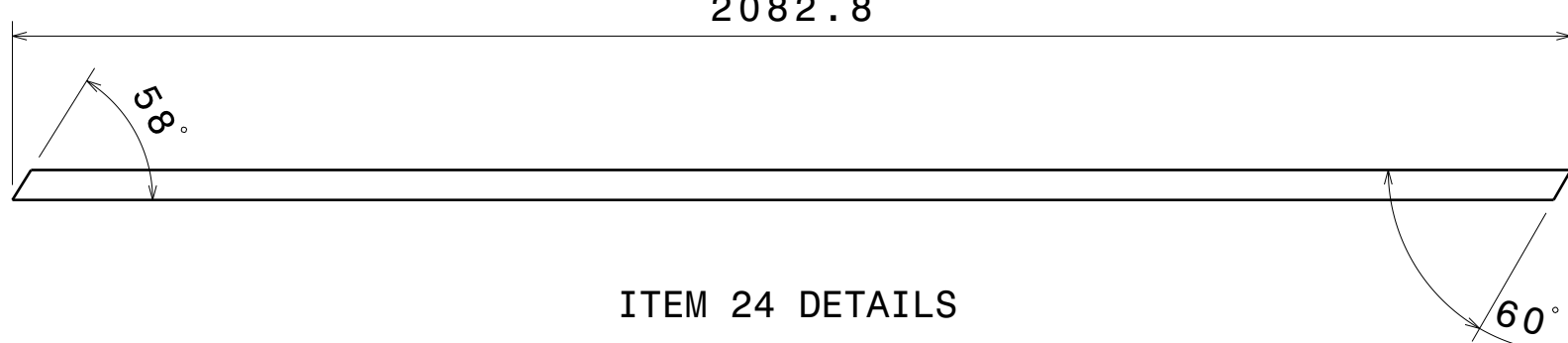
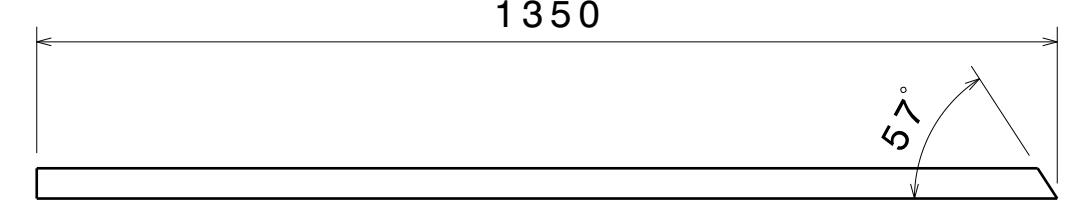
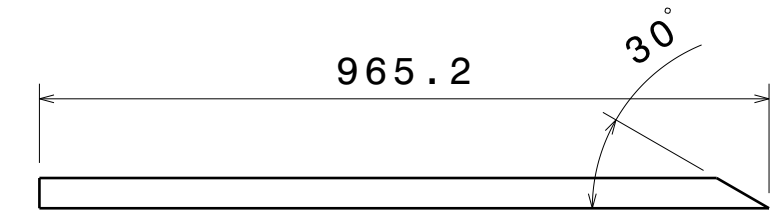
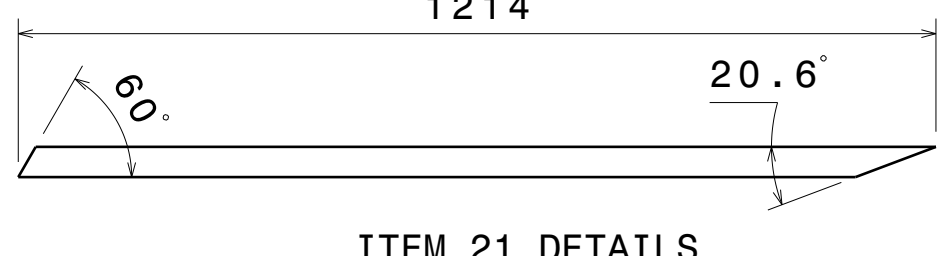
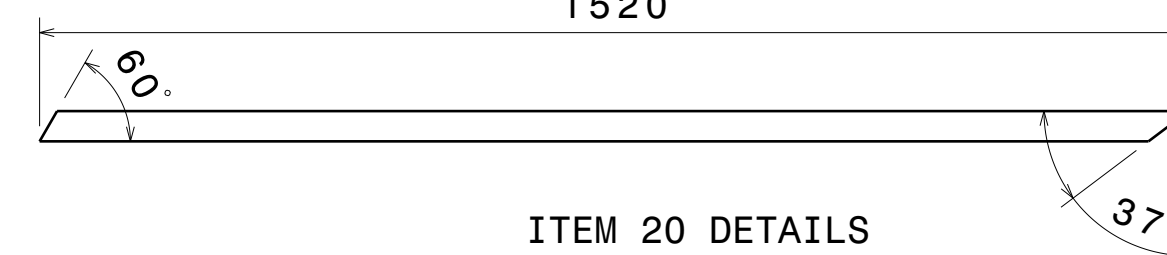
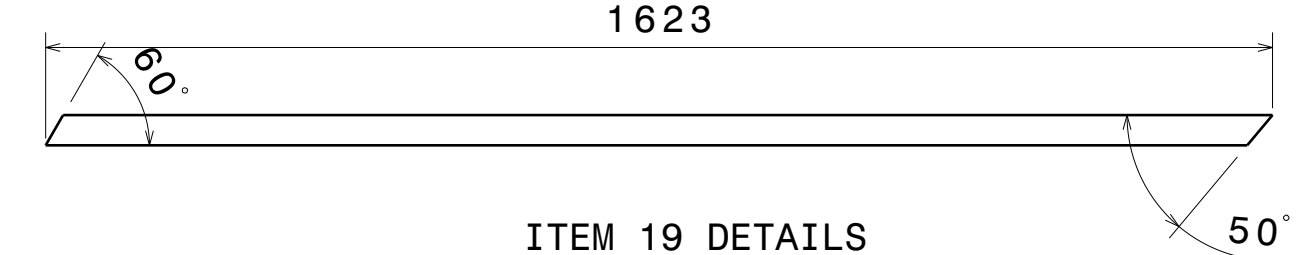
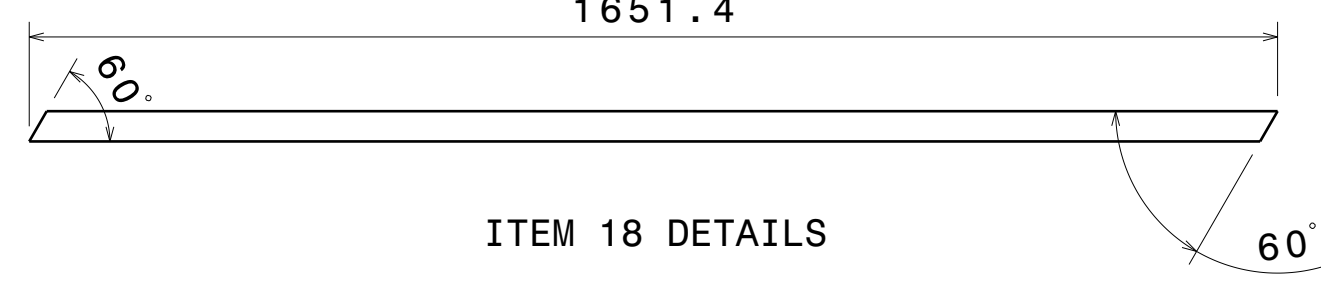
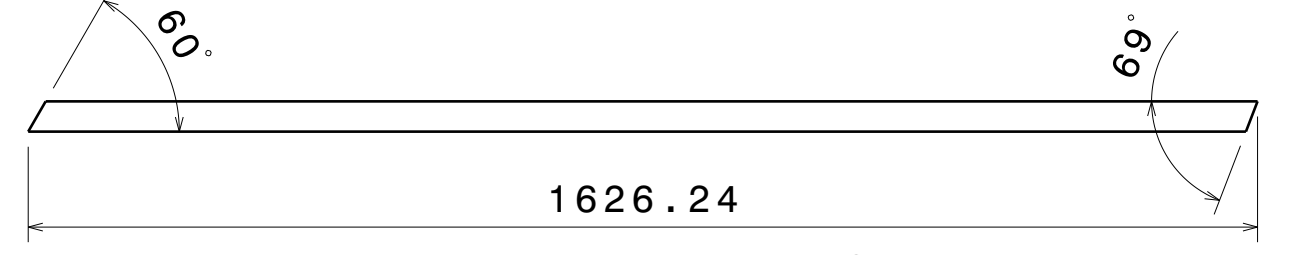
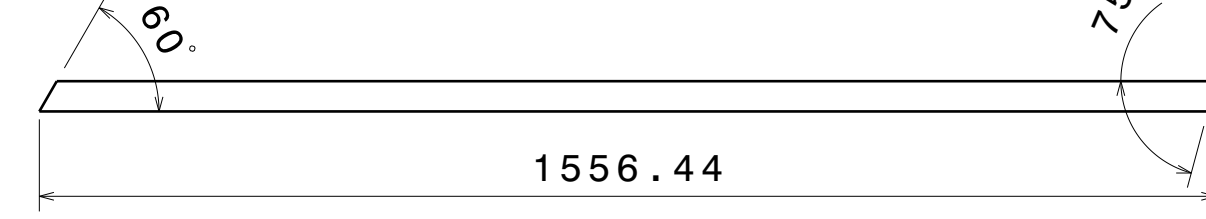
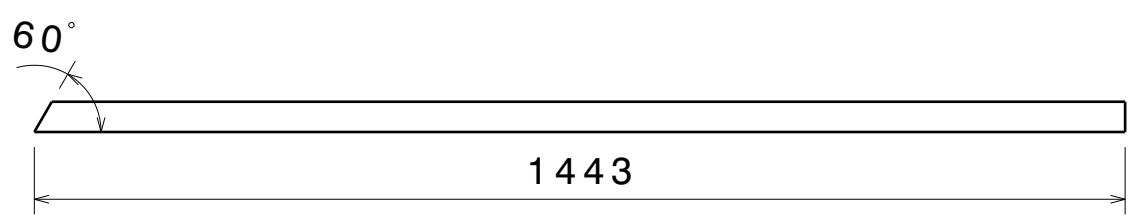
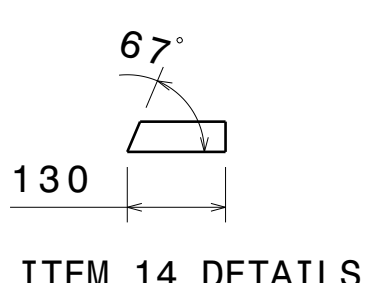
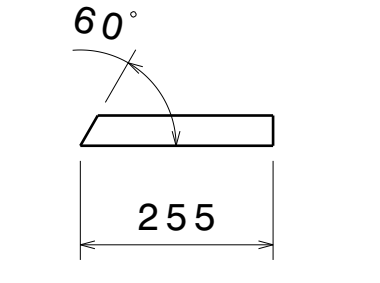
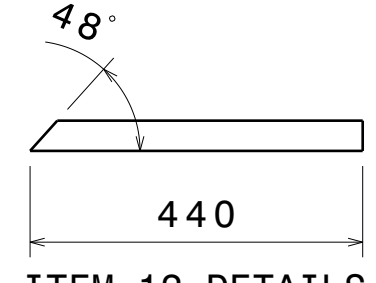
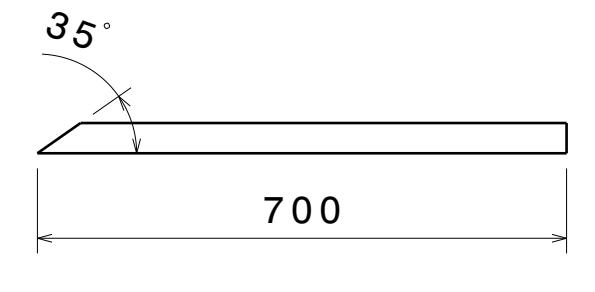
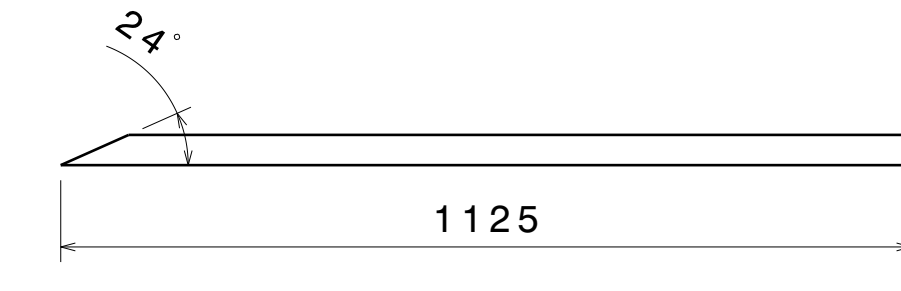
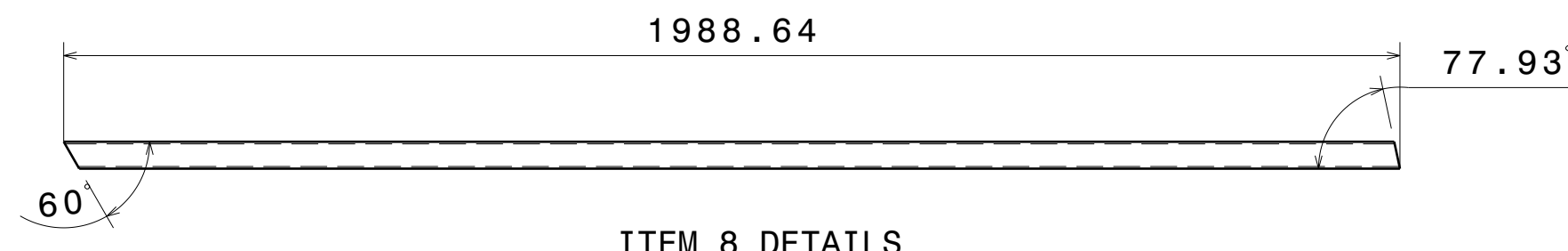
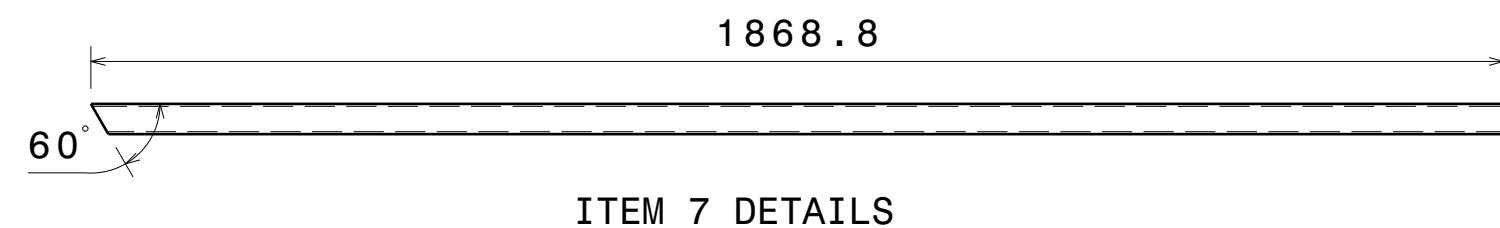
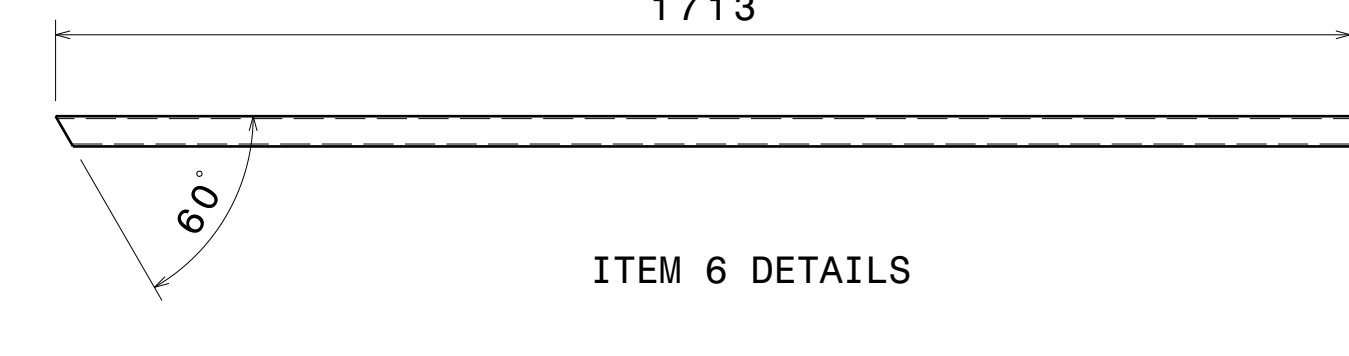
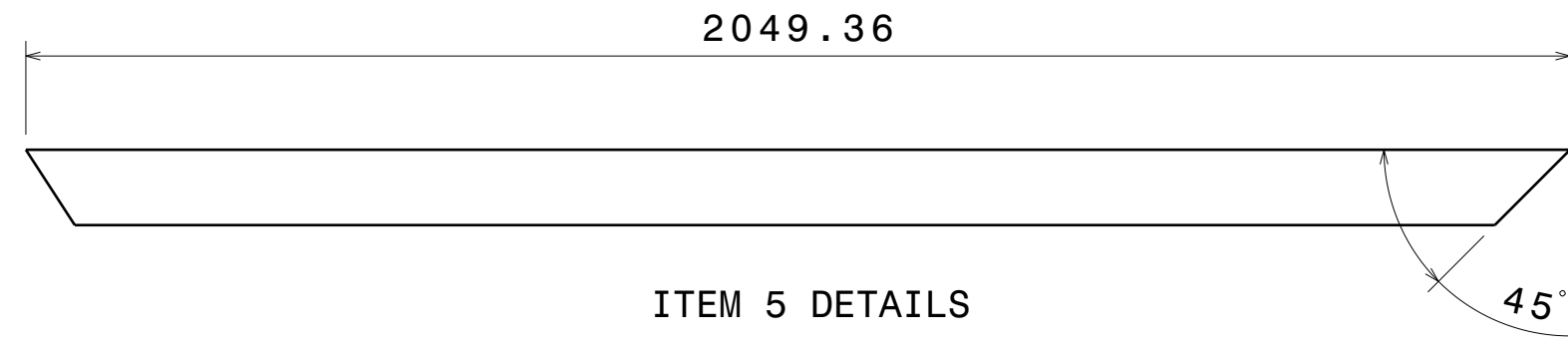
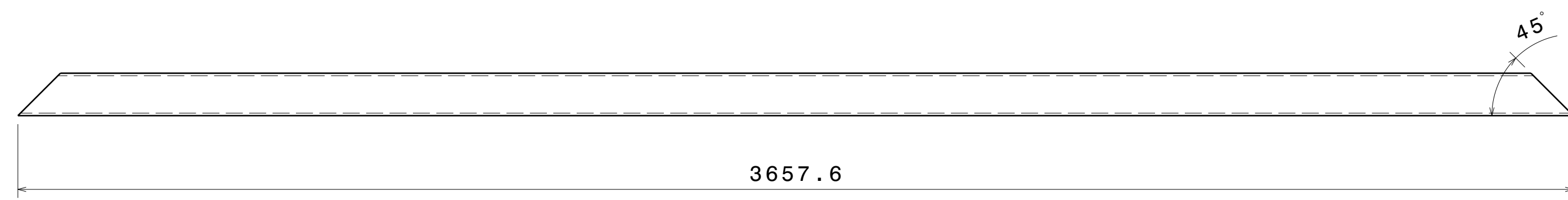

UNLESS OTHERWISE SPECIFIED DIMENSION ARE IN MM VIEWS: THIRD ANGLE PROJECTION

This drawing is our property. It can't be reproduced or communicated without our written agreement.

DRAWN BY: SB
 CHECKED BY: P2P Analysis & Solutions
 DESIGNED BY: P2P Analysis & Solutions

DRAWING TITLE		GATE 19	
SIZE	DRAWING NUMBER	REV	
A0	P2P APL_00019	00	
SCALE	NONE	WEIGHT (kg)	XXX
SHEET		3	

