

REV	DATE	DESCRIPTION
00	24MAR2020	INITIAL REVISION

NOTES:

- (⊥) ALL VERTICAL SUPPORTS ARE PERPENDICULAR.
- FLATNESS OF .5MM IS APPLIED BY DEFAULT.
- ⊥ WELD BEAD OF 2MM RADIUS IS FOLLOWED.
- ▽ SURFACE FINISH MEDIUM TO SMOOTH IS USED.
- ALL TUBES ARE AS PER APL APOLLO STANDARD. CHANGES MAY EFFECT THE LOAD CAPACITY.
- ALL HORIZONTAL AND VERTICAL TUBES ARE PERPENDICULAR TO EACH OTHER WITH ±1 DEG.
- FINE WELDING IS REQUIRED AS PER MENTIONED DETAILS AND FINISHING.
- HIGHER CURRENT WELDING MAY AFFECT THE BRITTLENESS OF MATERIAL WHICH LATER MAY RAISE TO WEAKENING OF STRUCTURE.
- SOME DIMENSIONS ARE DUAL DIMENSIONS WITH BOTH MM & INCH.

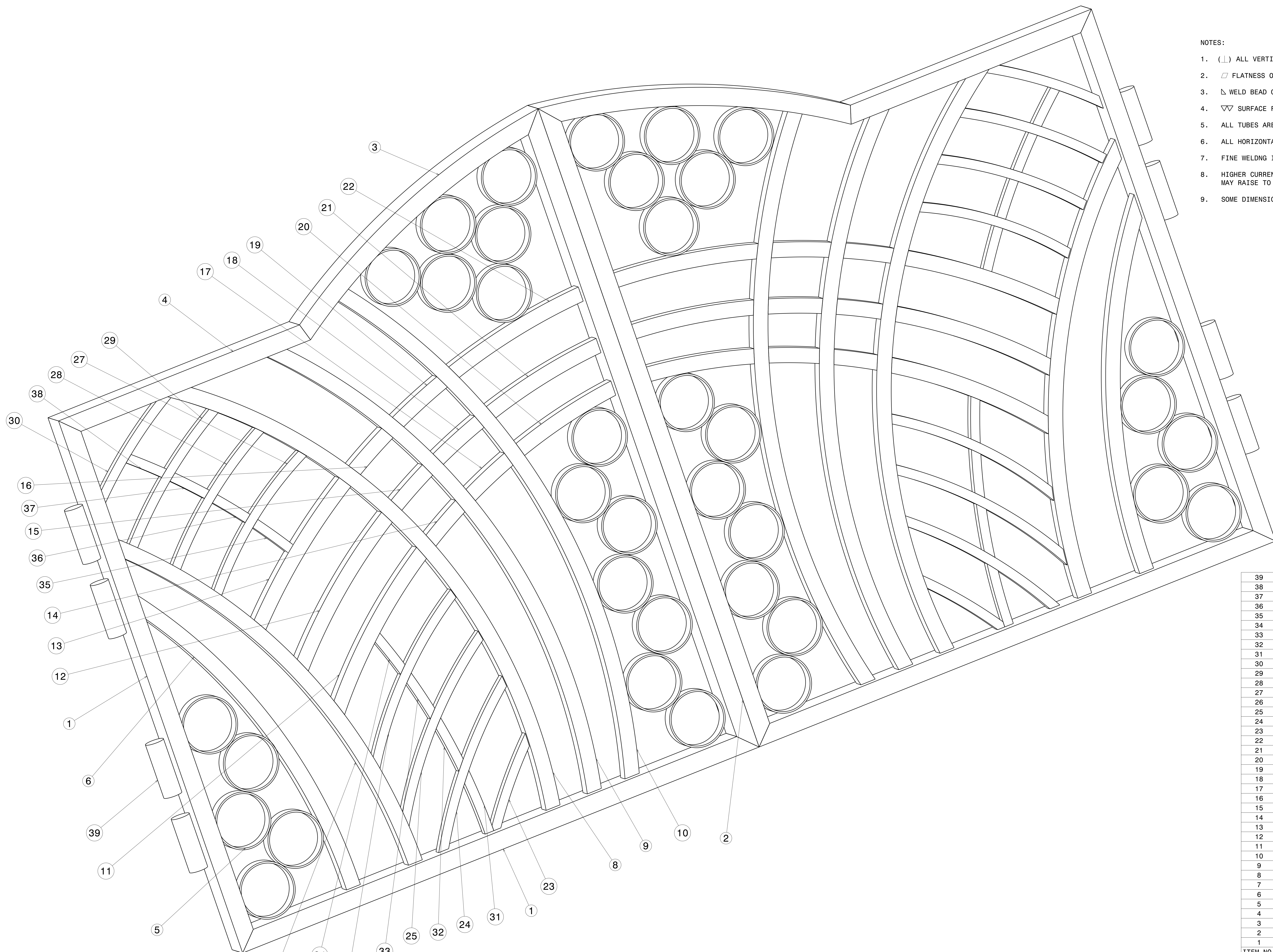

Isometric view

ITEM NO.	PART NUMBER	DESCRIPTION	QTY.
39	Hinge		8
38	Square tube 33.1 Frame 38	25 X 25 X 2 X 105	2
37	Square tube 33.1 Frame 37	25 X 25 X 2 X 106	2
36	Square tube 33.1 Frame 36	25 X 25 X 2 X 105	2
35	Square tube 33.1 Frame 35	25 X 25 X 2 X 118	2
34	Square tube 33.1 Frame 34	25 X 25 X 2 X 125	2
33	Square tube 33.1 Frame 33	25 X 25 X 2 X 135	2
32	Square tube 33.1 Frame 32	25 X 25 X 2 X 135	2
31	Square tube 33.1 Frame 31	25 X 25 X 2 X 175	2
30	Square tube 33.1 Frame 30	25 X 25 X 2 X 339	2
29	Square tube 33.1 Frame 29	25 X 25 X 2 X 416	2
28	Square tube 33.1 Frame 28	25 X 25 X 2 X 425	2
27	Square tube 33.1 Frame 27	25 X 25 X 2 X 433	2
26	Square tube 33.1 Frame 26	25 X 25 X 2 X 498	2
25	Square tube 33.1 Frame 25	25 X 25 X 2 X 535	2
24	Square tube 33.1 Frame 24	25 X 25 X 2 X 495	2
23	Square tube 33.1 Frame 23	25 X 25 X 2 X 260	2
22	Square tube 33.1 Frame 22	40 X 40 X 3.2 X 409	2
21	Square tube 33.1 Frame 20	40 X 40 X 3.2 X 347	2
20	Square tube 33.1 Frame 20	40 X 40 X 3.2 X 305	2
19	Square tube 33.1 Frame 19	40 X 40 X 3.2 X 160	2
18	Square tube 33.1 Frame 18	40 X 40 X 3.2 X 149	2
17	Square tube 33.1 Frame 17	40 X 40 X 3.2 X 140	2
16	Square tube 33.1 Frame 16	40 X 40 X 3.2 X 132	2
15	Square tube 33.1 Frame 15	40 X 40 X 3.2 X 125	2
14	Square tube 33.1 Frame 14	40 X 40 X 3.2 X 120	2
13	Square tube 33.1 Frame 13	40 X 40 X 3.2 X 440	2
12	Square tube 33.1 Frame 12	40 X 40 X 3.2 X 451	2
11	Square tube 33.1 Frame 11	40 X 40 X 3.2 X 465	2
10	Square tube 33.1 Frame 10	40 X 40 X 3.2 X 1585	2
9	Square tube 33.1 Frame 9	40 X 40 X 3.2 X 1632	2
8	Square tube 33.1 Frame 8	40 X 40 X 3.2 X 1615	2
7	Square tube 33.1 Frame 7	40 X 40 X 3.2 X 1243.6	2
6	Square tube 33.1 Frame 6	40 X 40 X 3.2 X 1017	2
5	Round tube 33.1 Frame 5	152.4 X 4.5 X 40	36
4	Rect. Tube 33.1 Frame 4	96 X 48 X 3.2 X 715	2
3	Rect. Tube 33.1 Frame 3	96 X 48 X 3.2 X 862.6	2
2	Rect. Tube 33.1 Frame 2	96 X 48 X 3.2 X 1800	2
1	Rect. Tube 33.1 Frame 1	96 X 48 X 3.2 X 1500	4

This drawing is our property. It can't be reproduced or communicated without our written agreement.

**APL APOLLO TUBES LTD.**

DRAWING TITLE: **GATE -33**

SCALE: **As Indicated** WEIGHT(kg) **220kg** SHEET **1 OF 5**

UNLESS OTHERWISE SPECIFIED DIMENSION ARE IN MM VIEWS: THIRD ANGLE PROJECTION

DRAWN BY	AS	DATE	24MAR2020
CHECKED BY	P2P Analysis & Solutions	DATE	24MAR2020
DESIGNED BY	P2P Analysis & Solutions	DATE	24MAR2020

SIZE	A0	DRAWING NUMBER	P2P GATE 00033	REV	00
------	----	----------------	----------------	-----	----



REV	DATE	DESCRIPTION
00	24MAR2020	INITIAL REVISION

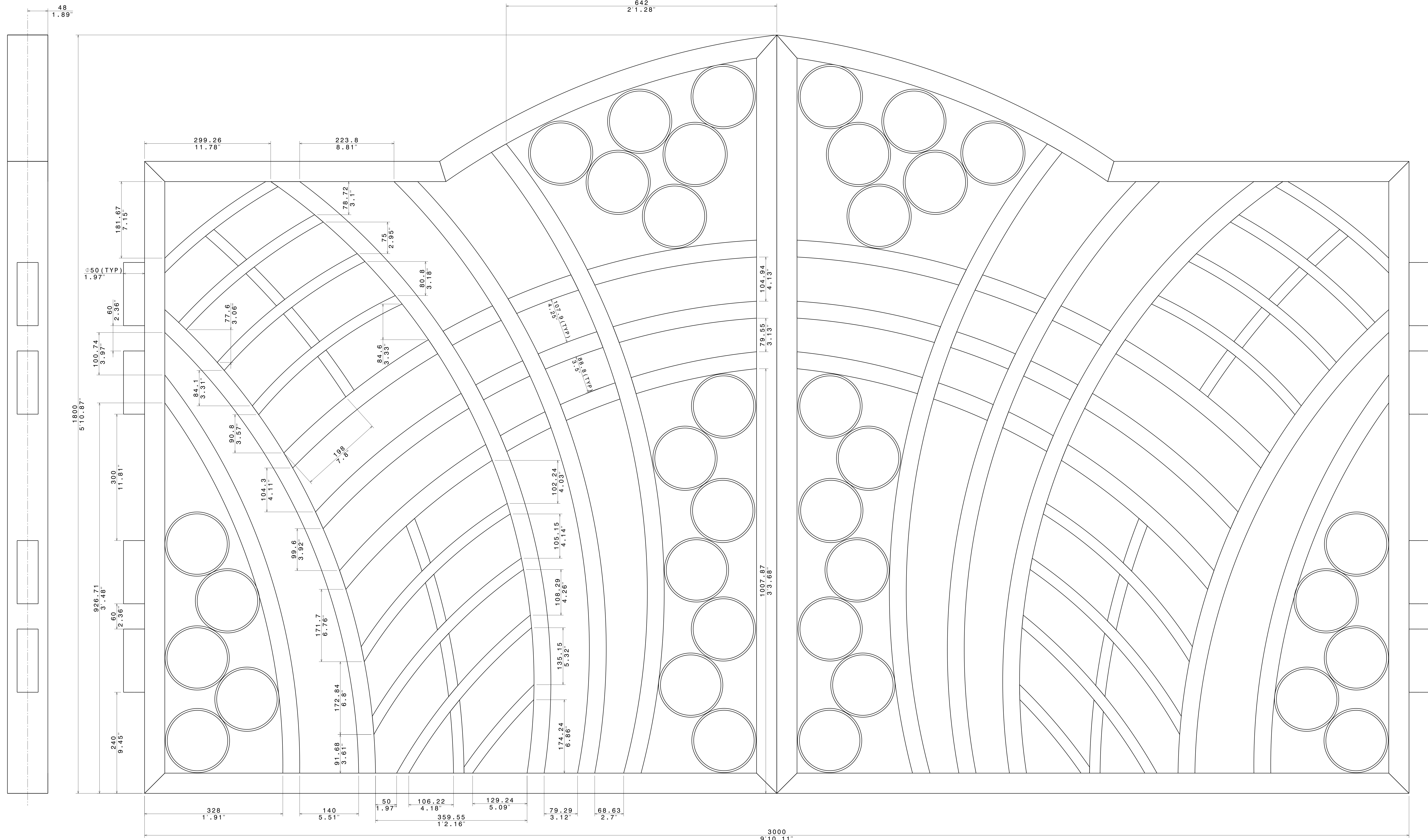

This drawing is our property. It can't be reproduced or communicated without our written agreement.

**APL APOLLO TUBES LTD.** 

**DRAWING TITLE**  
GATE - 33

<b>DRAWN BY</b> SB	<b>DATE</b> 24MAR2020	<b>SIZE</b> A0	<b>DRAWING NUMBER</b> P2P_GATE_00033	<b>REV</b> 00
<b>CHECKED BY</b> P2P Analysis & Solutions	<b>DATE</b> 24MAR2020	<b>SCALE</b> NONE	<b>WEIGHT (kg)</b> XXX	<b>SHEET 2 OF 5</b>
<b>DESIGNED BY</b> P2P Analysis & Solutions	<b>DATE</b> 24MAR2020			

UNLESS OTHERWISE SPECIFIED DIMENSION ARE IN MM  
VIEWS: THIRD ANGLE PROJECTION

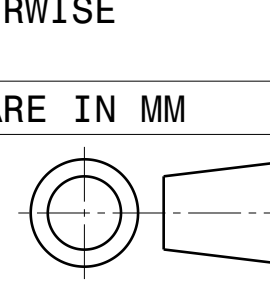



REV	DATE	DESCRIPTION
00	24MAR2020	INITIAL REVISION

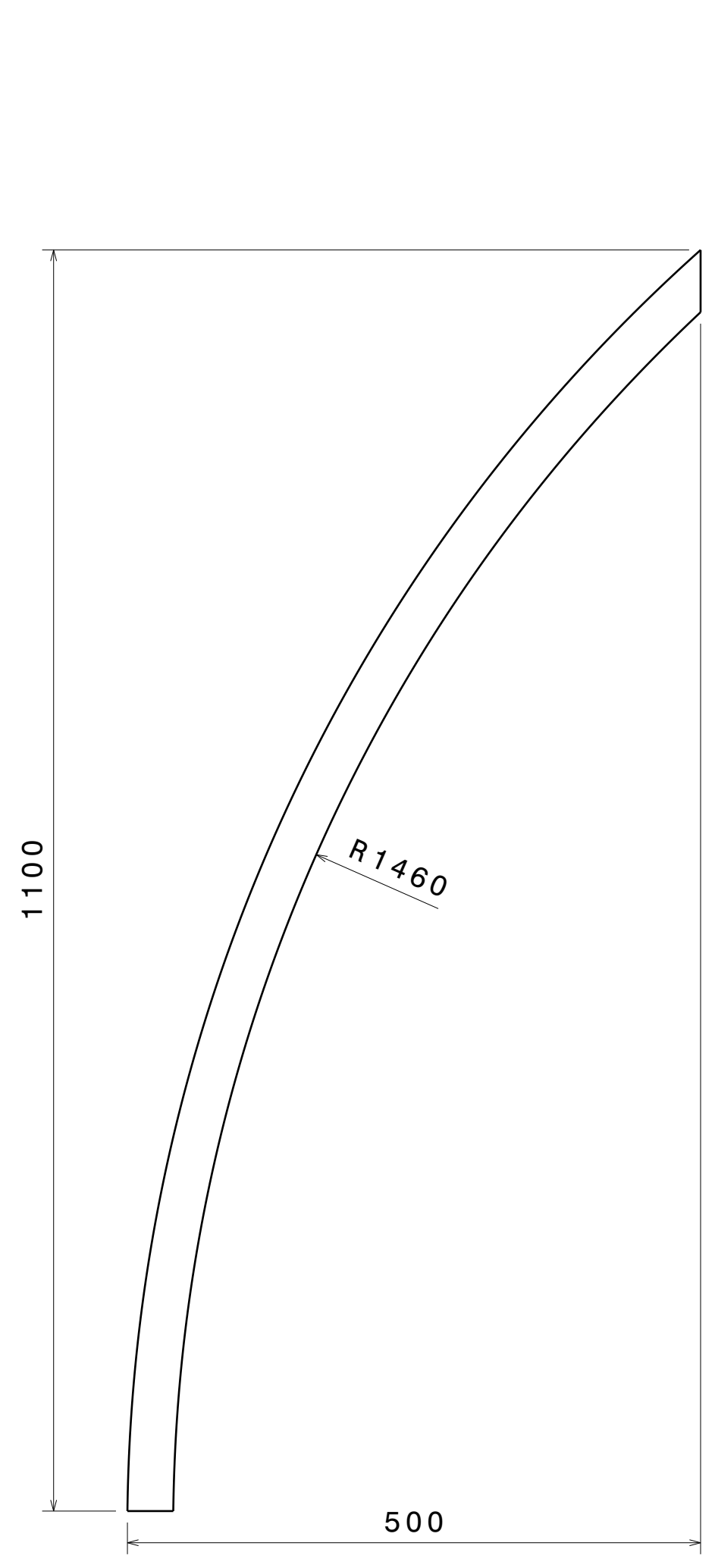

ITEM 7 DETAILS  
Sq\_tube 33.1 Frame 7

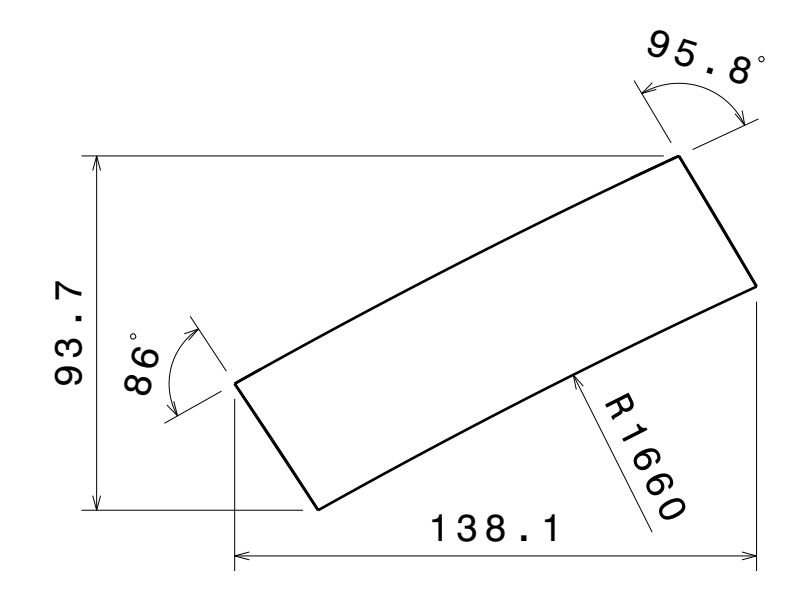

ITEM 16 DETAILS  
Sq\_tube 33.1 Frame 16

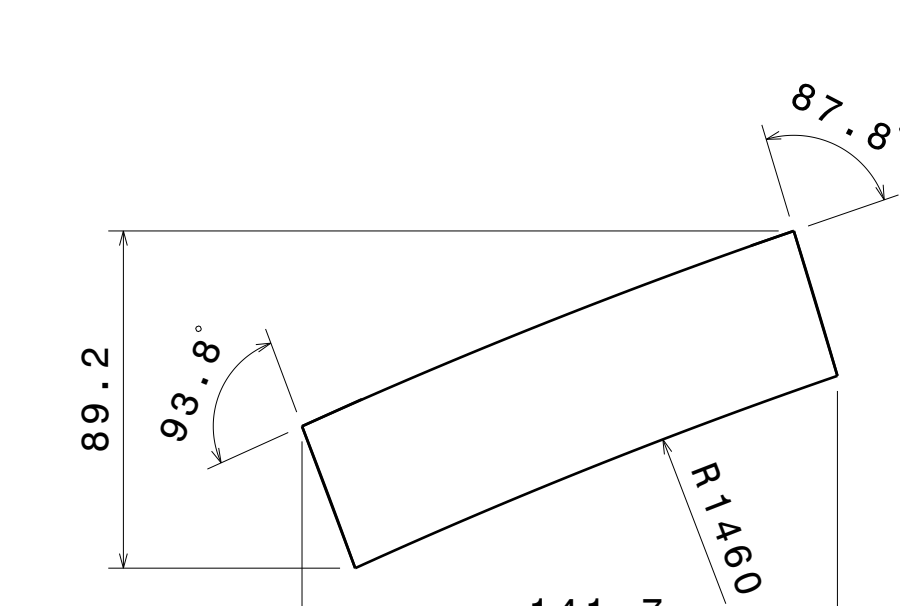

ITEM 17 DETAILS  
Sq\_tube 33.1 Frame 17

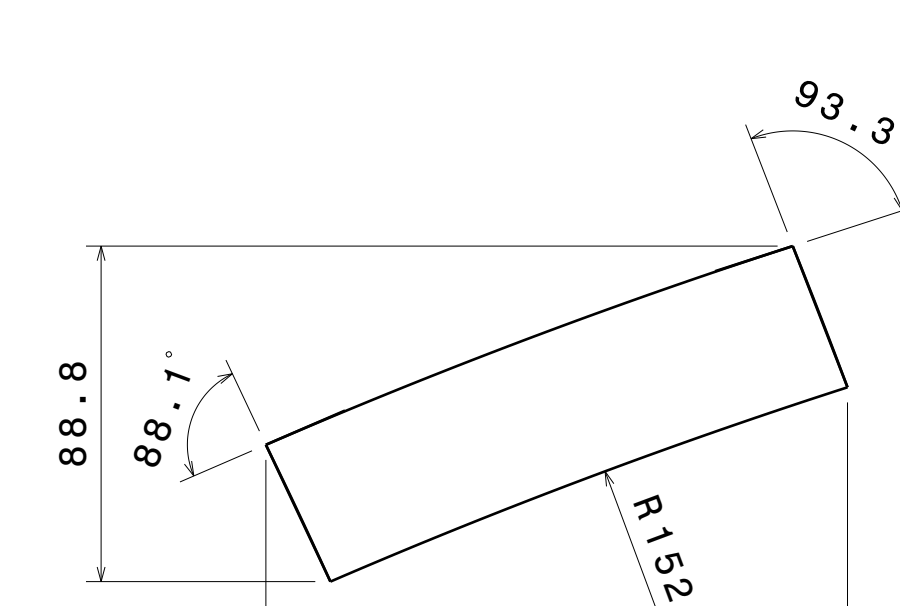

ITEM 18 DETAILS  
Sq\_tube 33.1 Frame 18

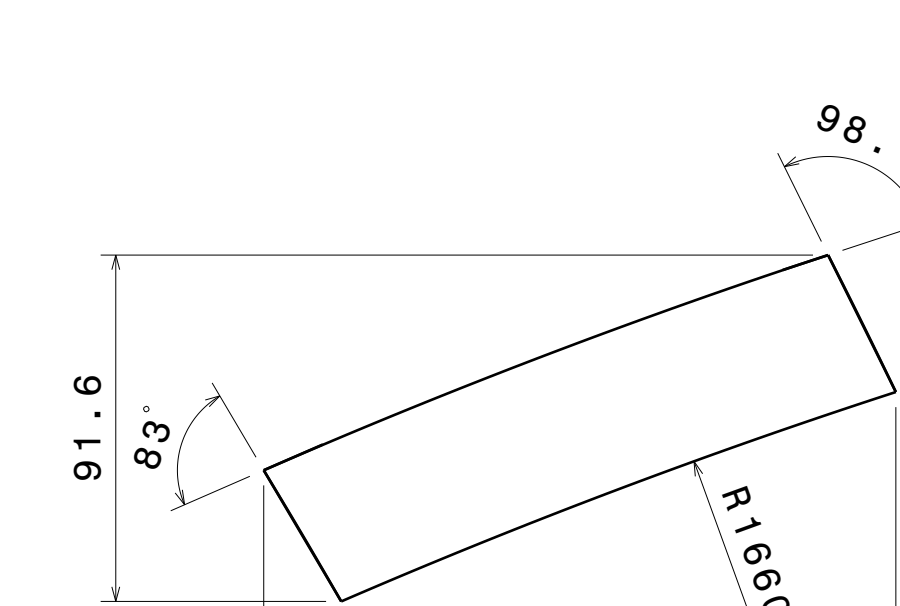

ITEM 19 DETAILS  
Sq\_tube 33.1 Frame 19

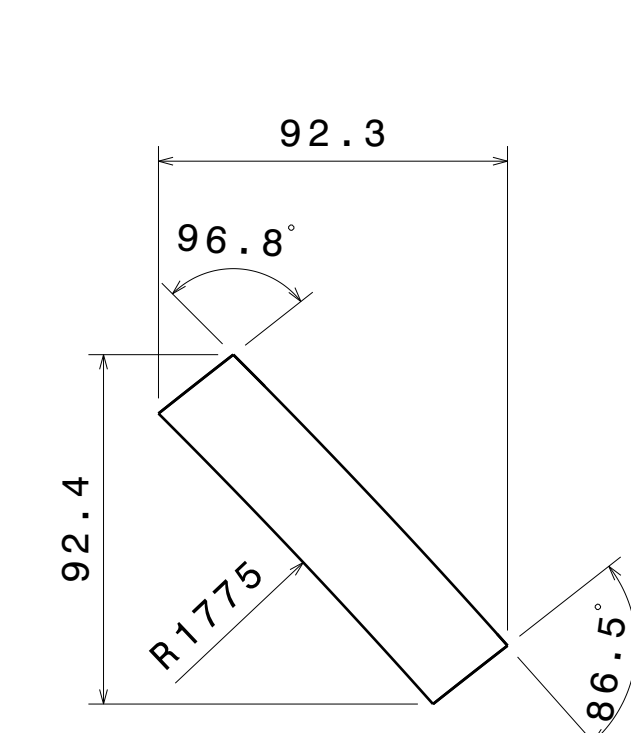

ITEM 37 DETAILS  
Sq\_tube 33.1 Frame 37

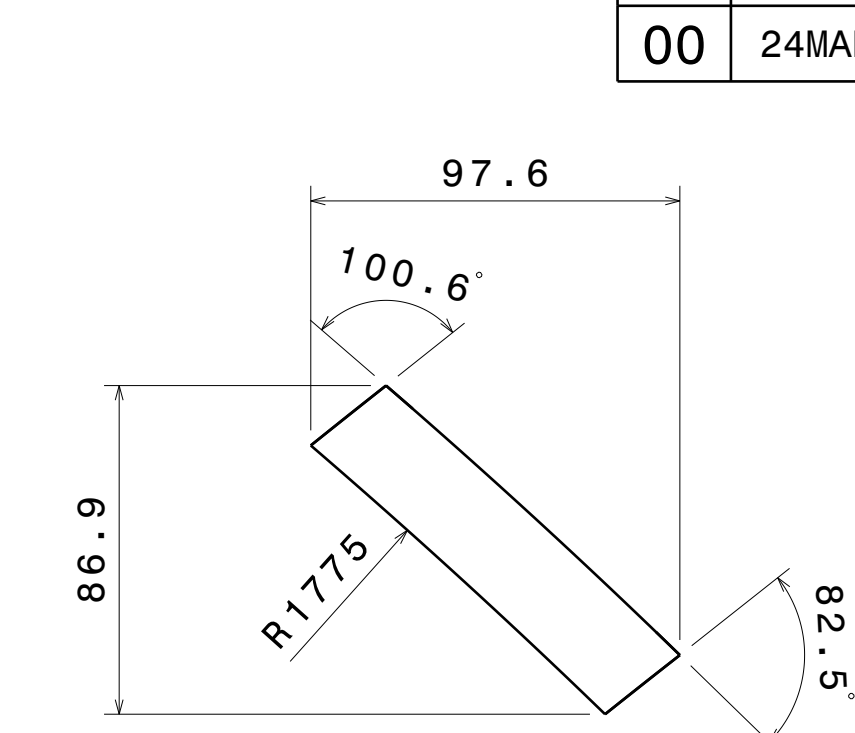

ITEM 38 DETAILS  
Sq\_tube 33.1 Frame 38

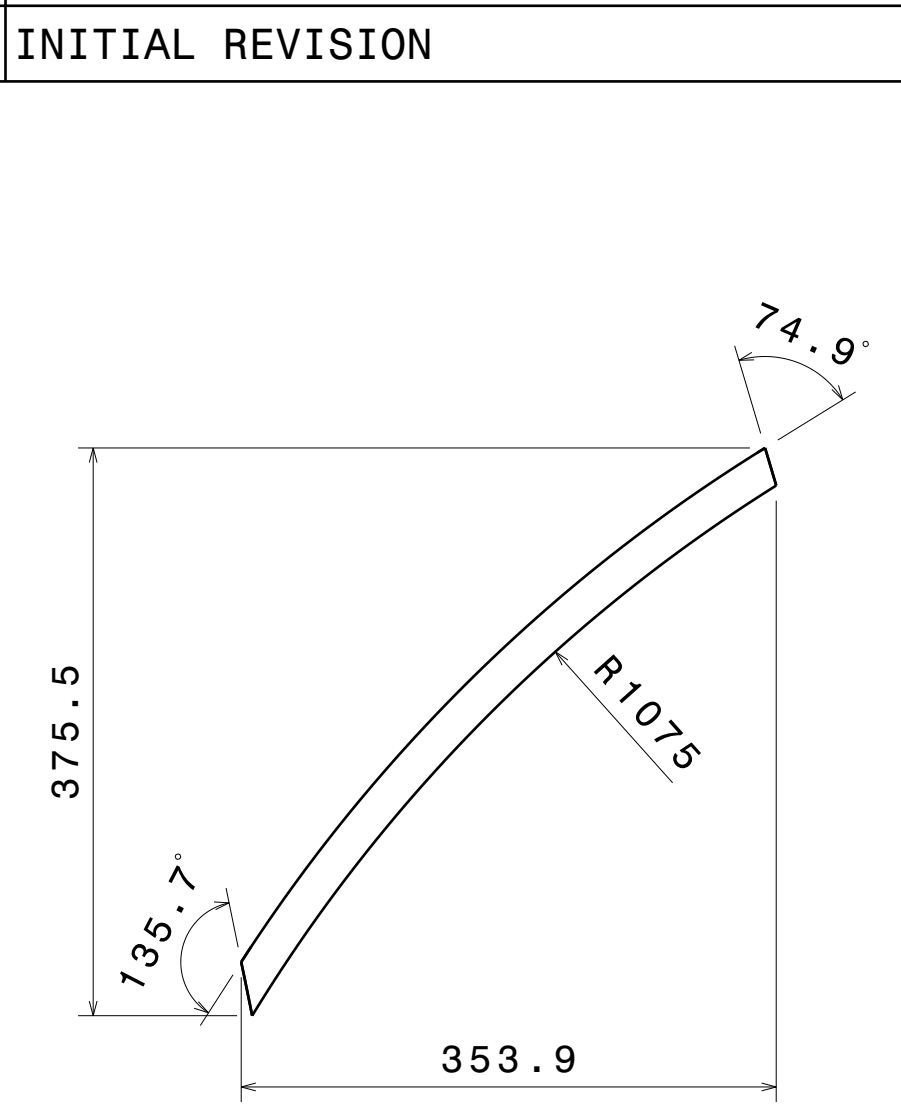

ITEM 26 DETAILS  
Sq\_tube 33.1 Frame 26

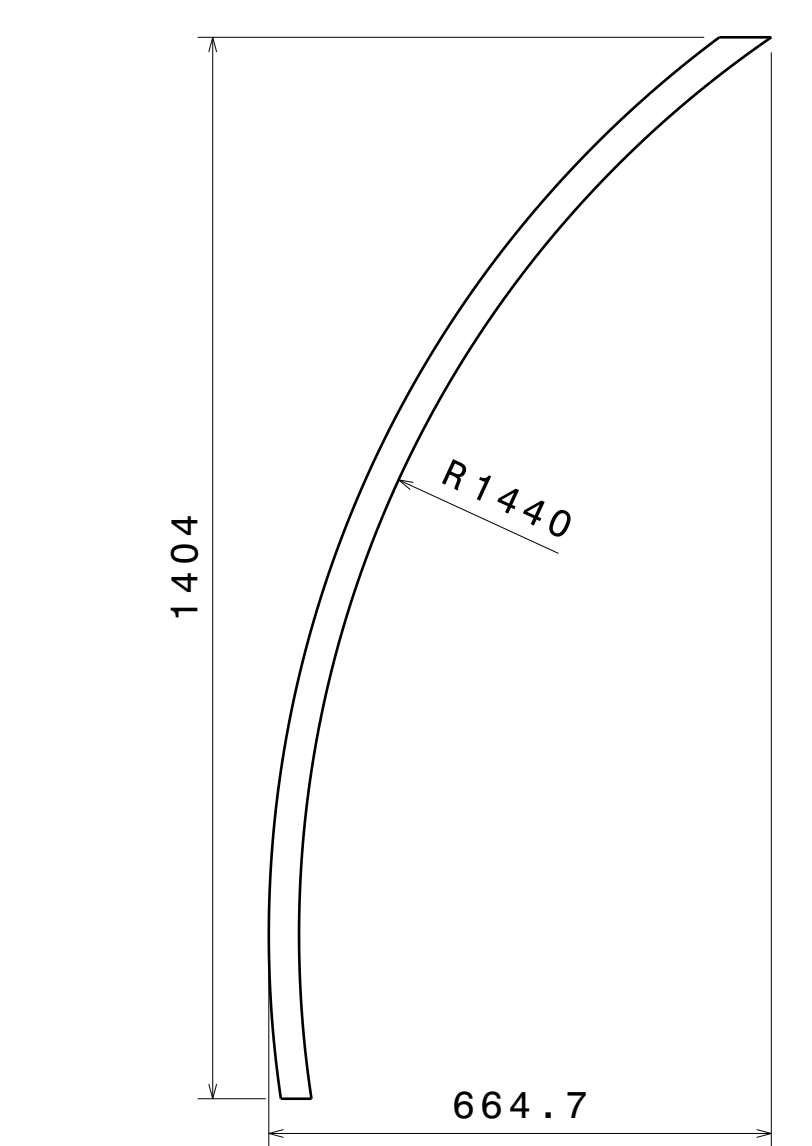

ITEM 8 DETAILS  
Sq\_tube 33.1 Frame 8

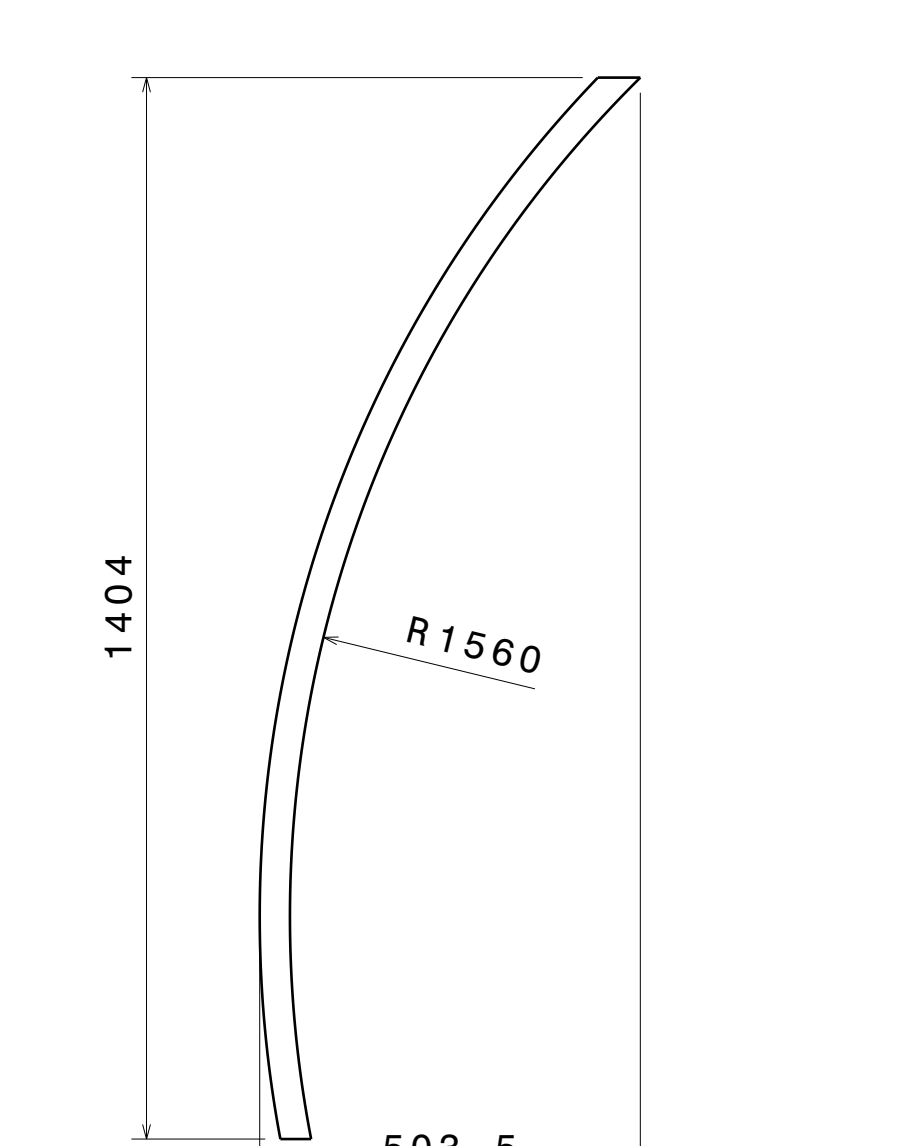

ITEM 9 DETAILS  
Sq\_tube 33.1 Frame 9

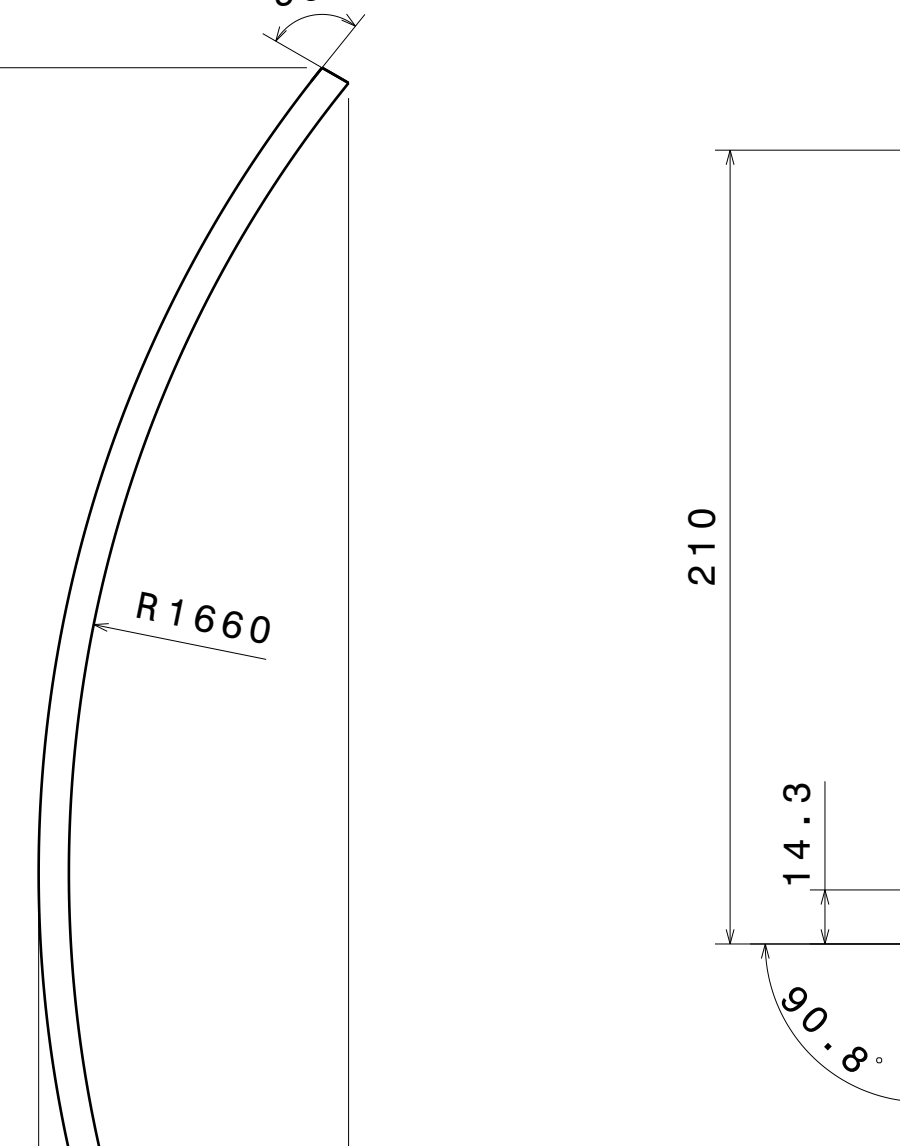

ITEM 10 DETAILS  
Sq\_tube 33.1 Frame 10

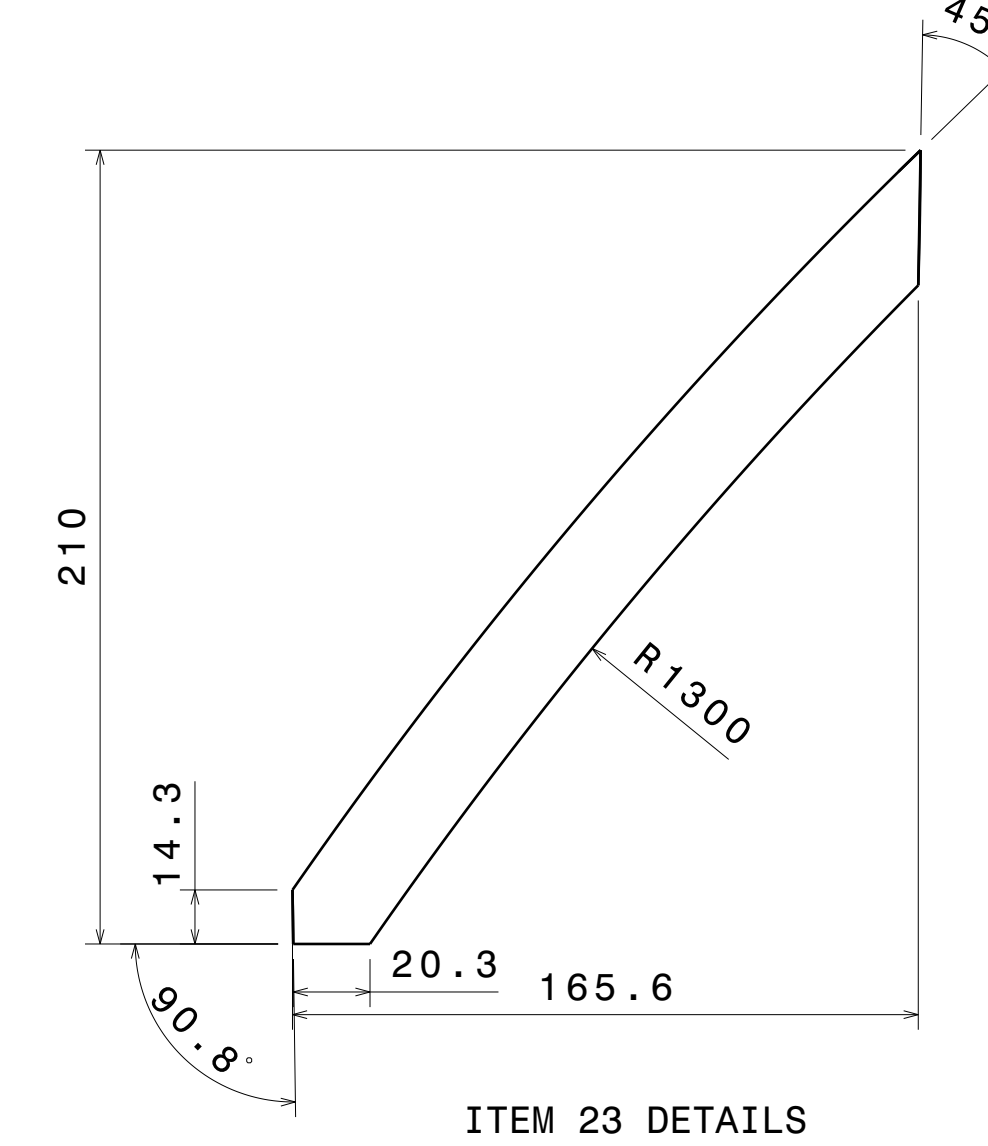

ITEM 23 DETAILS  
Sq\_tube 33.1 Frame 23

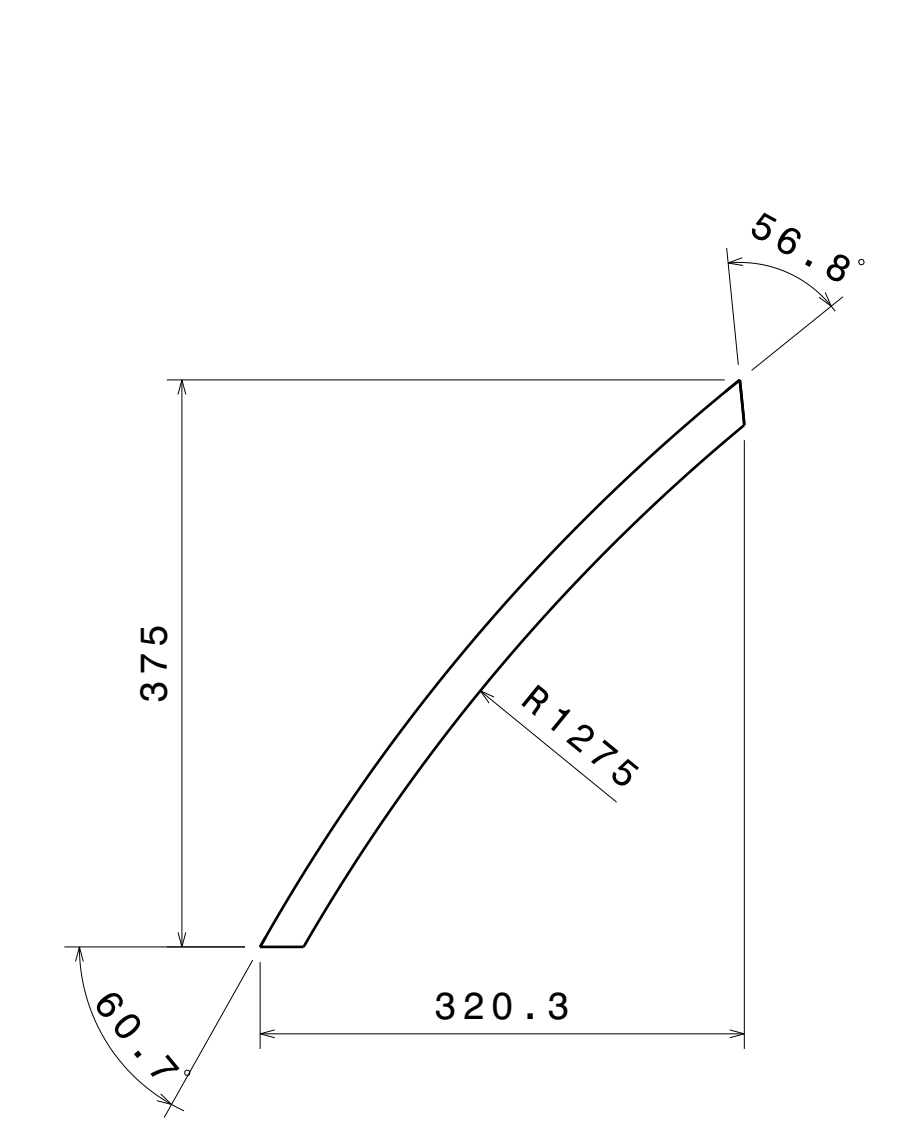

ITEM 24 DETAILS  
Sq\_tube 33.1 Frame 24

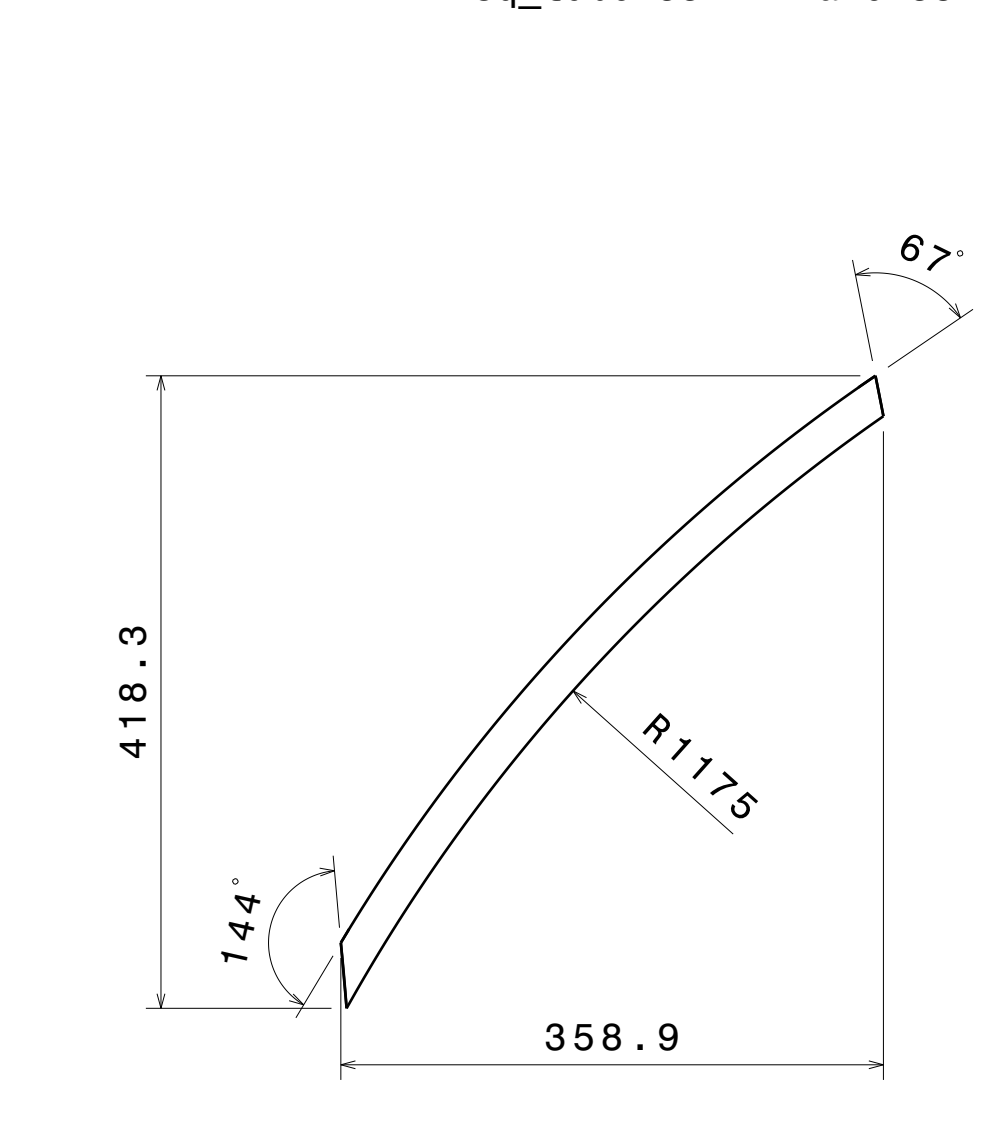

ITEM 25 DETAILS  
Sq\_tube 33.1 Frame 25

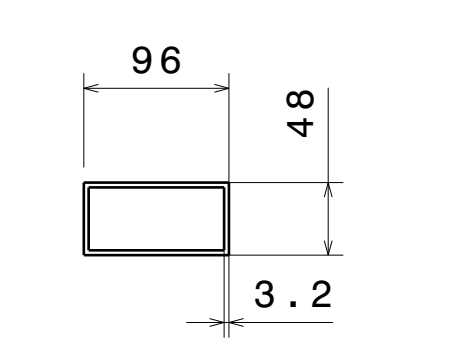

Section Detail of  
ITEM 1,2,3 & 4  
Scale: 1:5

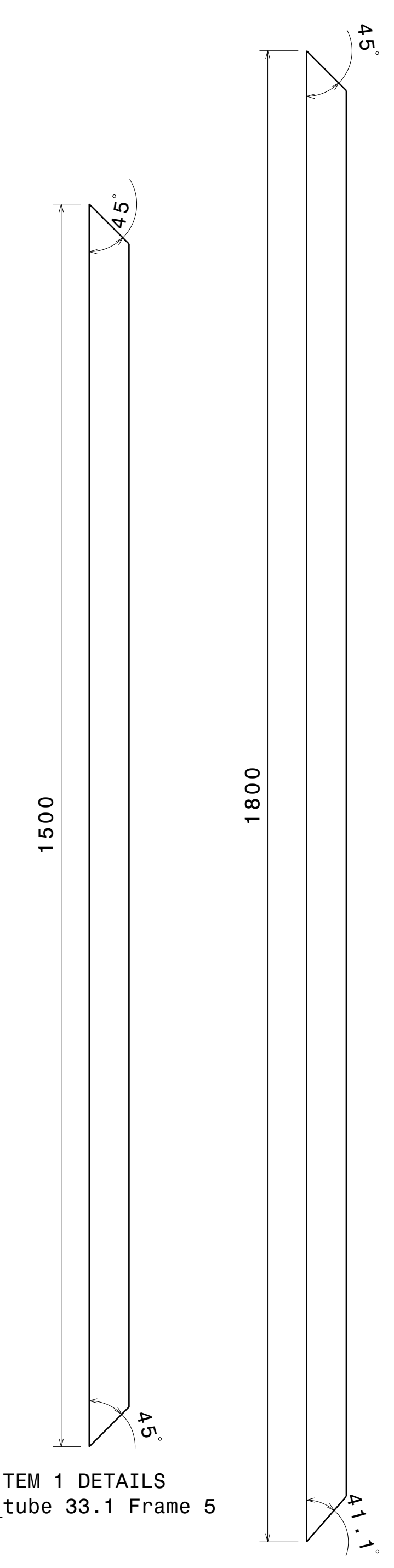

ITEM 1 DETAILS  
rect\_tube 33.1 Frame 5

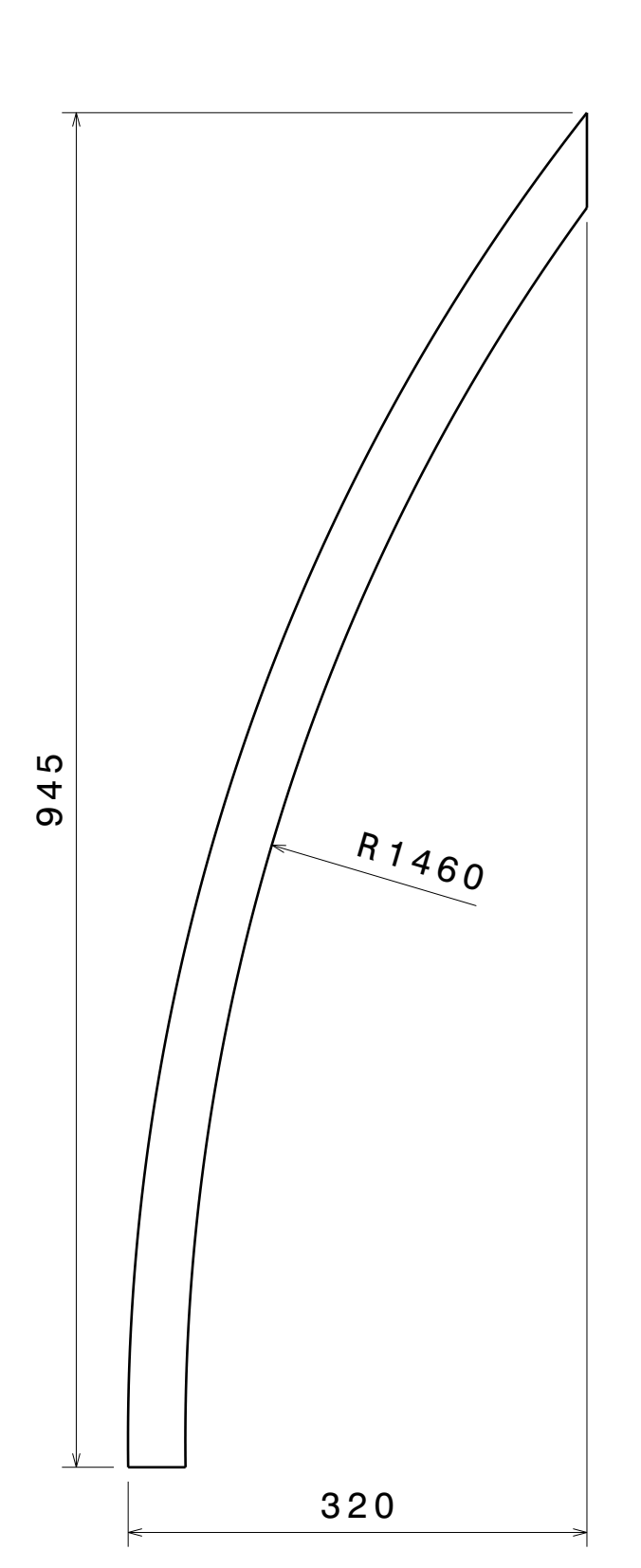

ITEM 6 DETAILS  
Sq\_tube 33.1 Frame 6

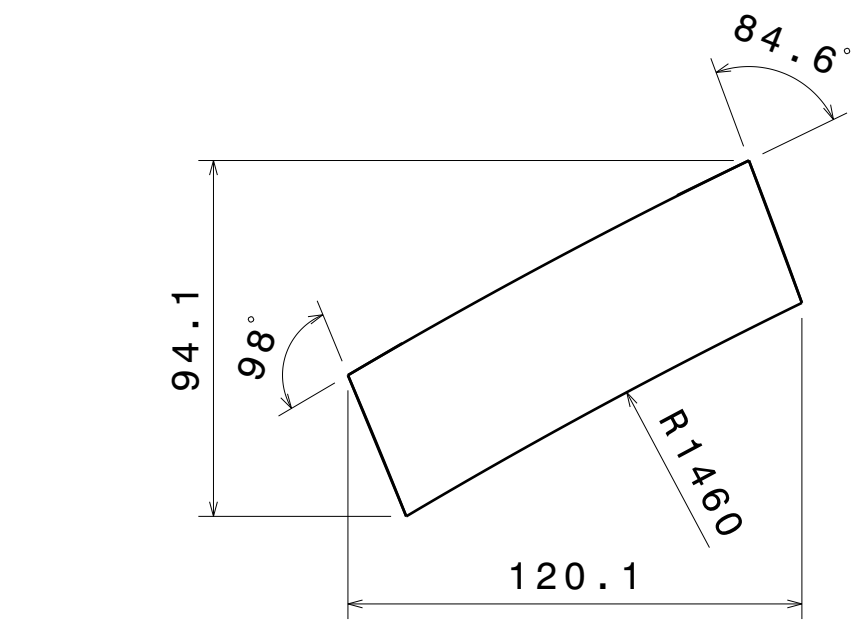

ITEM 14 DETAILS  
Sq\_tube 33.1 Frame 14

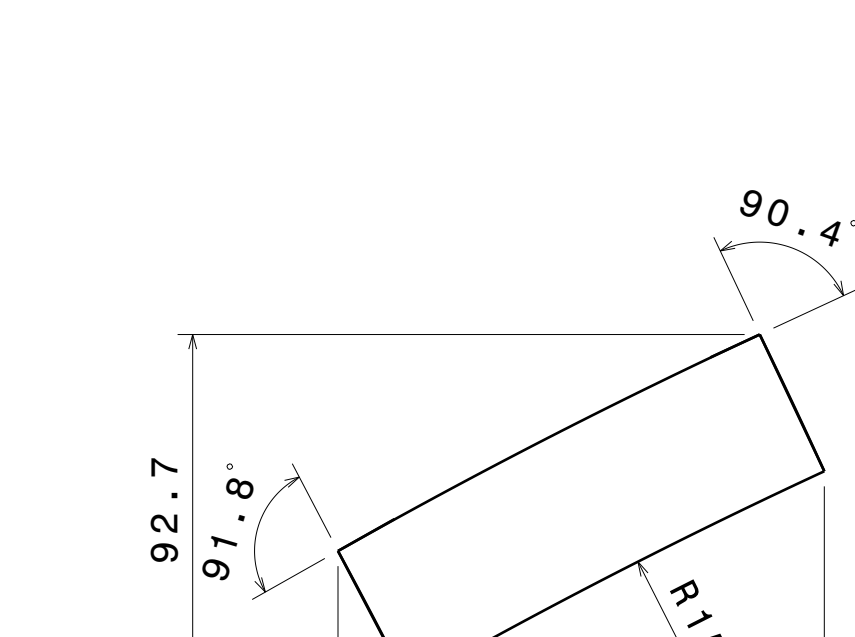

ITEM 15 DETAILS  
Sq\_tube 33.1 Frame 15

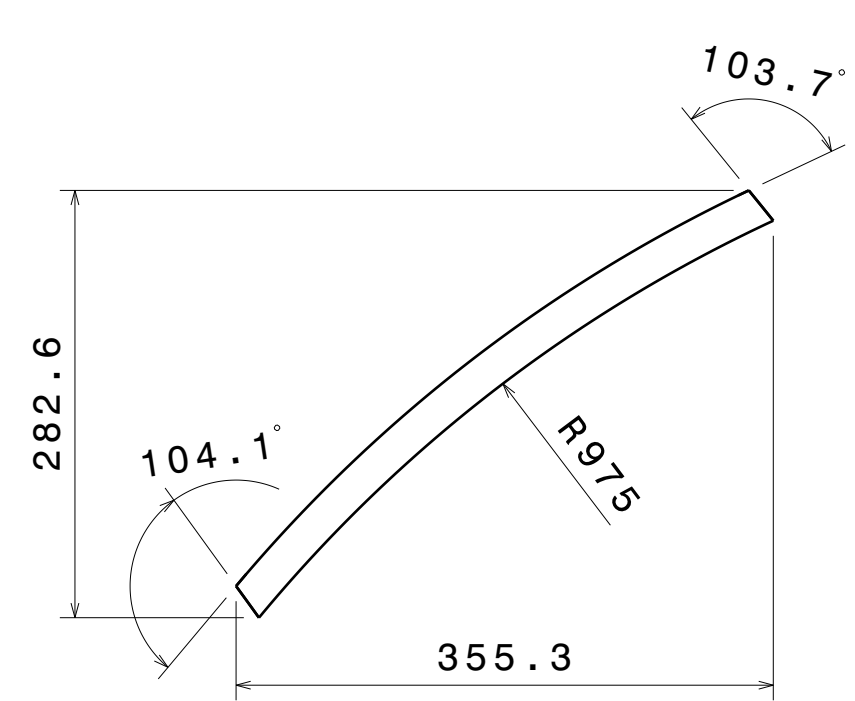

ITEM 27 DETAILS  
Sq\_tube 33.1 Frame 27

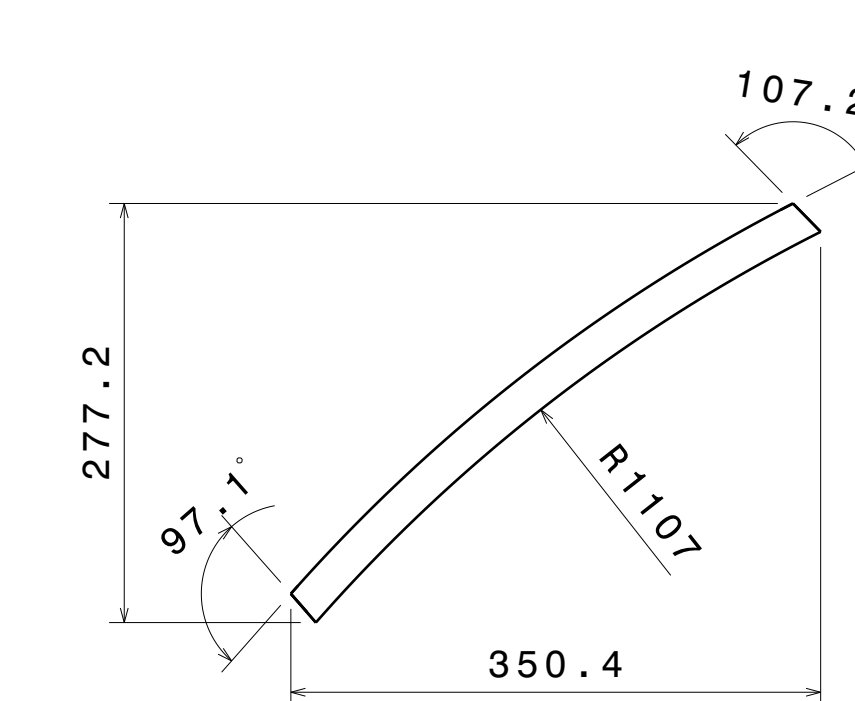

ITEM 28 DETAILS  
Sq\_tube 33.1 Frame 28

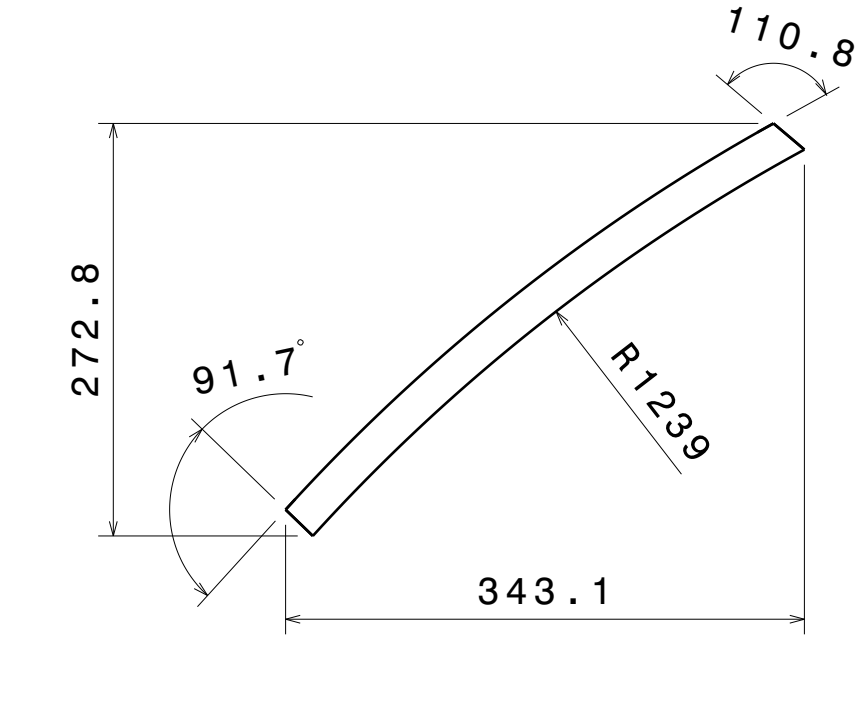

ITEM 29 DETAILS  
Sq\_tube 33.1 Frame 29

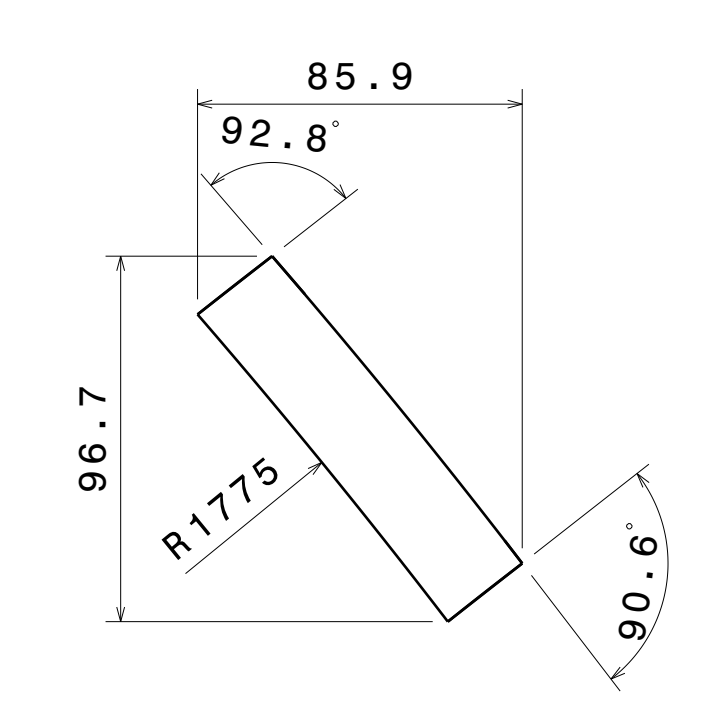

ITEM 36 DETAILS  
Sq\_tube 33.1 Frame 36

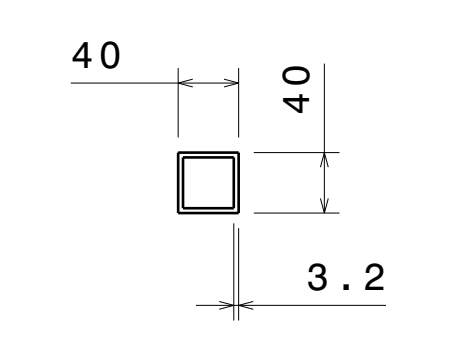

Section Detail of  
ITEM  
6,7,8,9,10,11,12,13,  
14,15,16,17,18,19,  
20,21 & 22  
Scale: 1:5

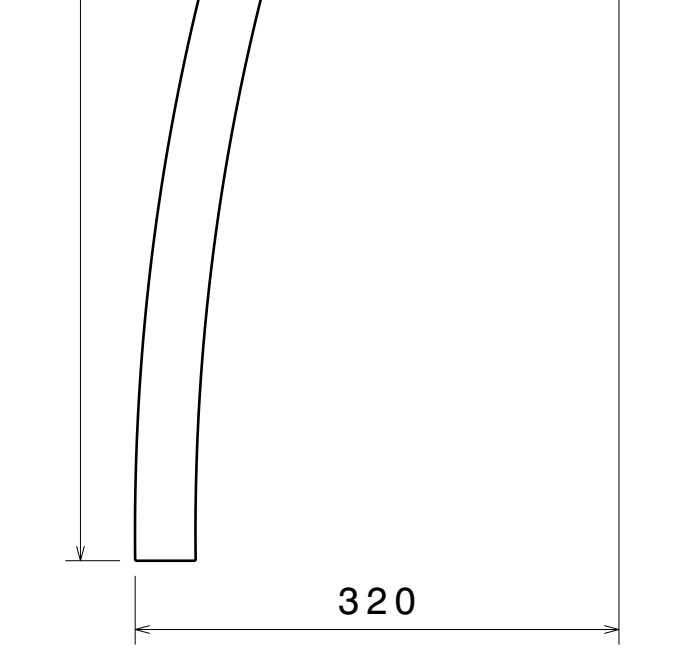

ITEM 13 DETAILS  
Sq\_tube 33.1 Frame 13

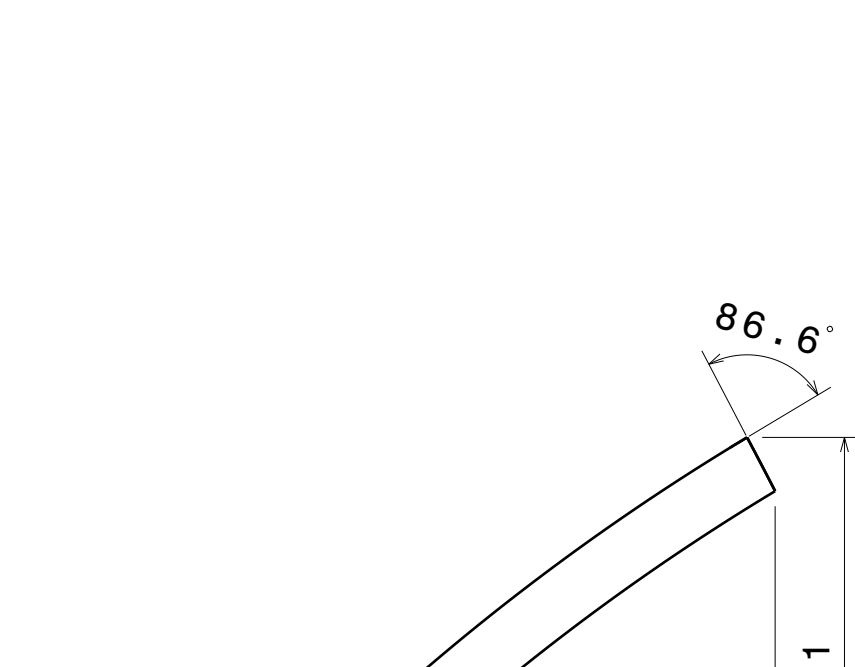

ITEM 12 DETAILS  
Sq\_tube 33.1 Frame 12

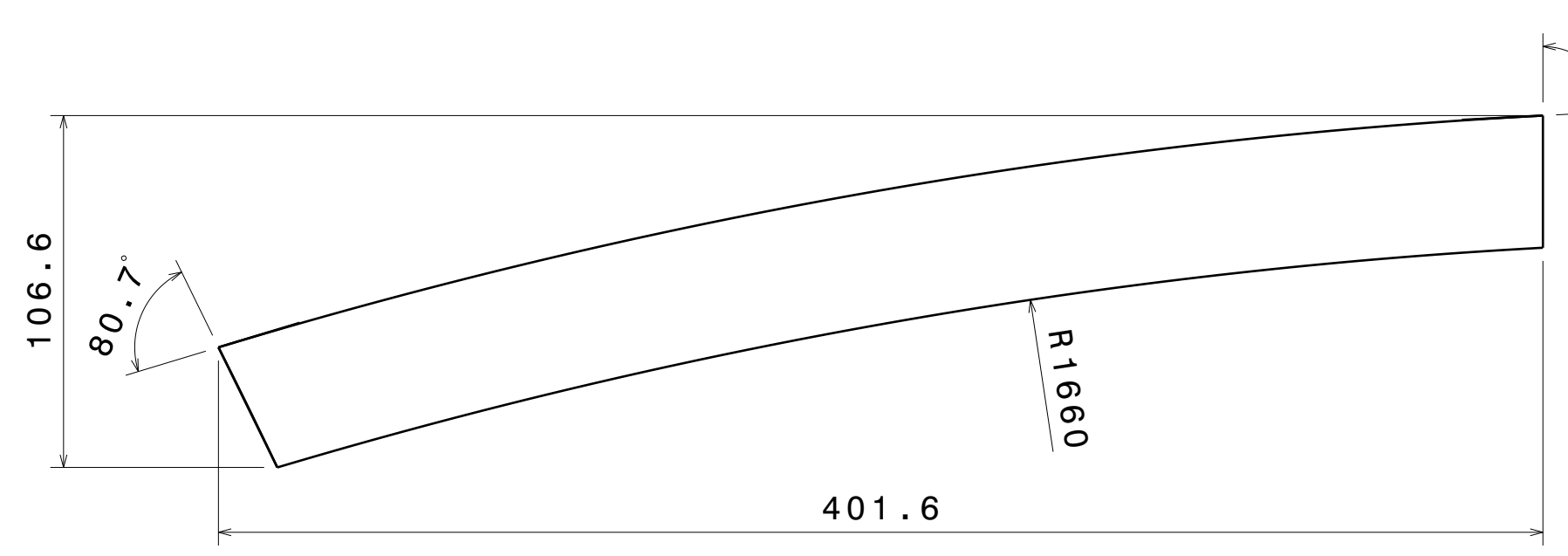

ITEM 22 DETAILS  
Sq\_tube 33.1 Frame 22

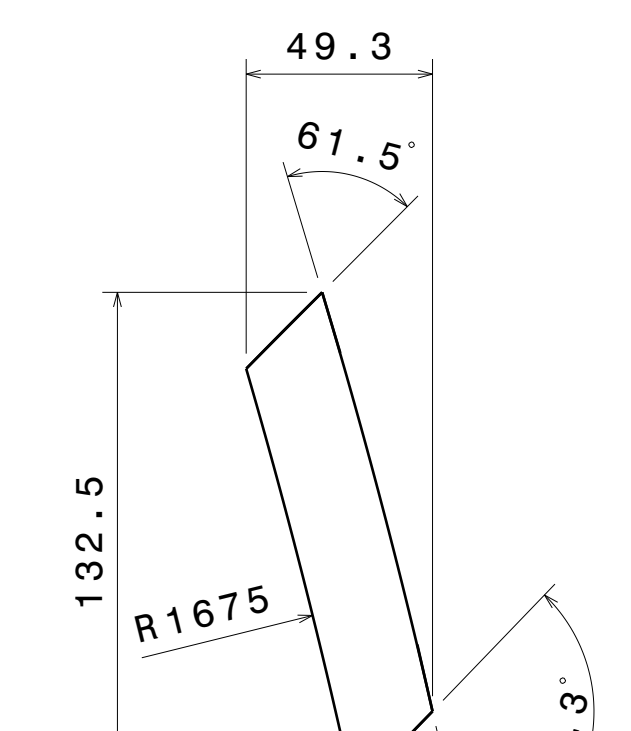

ITEM 33 DETAILS  
Sq\_tube 33.1 Frame 33

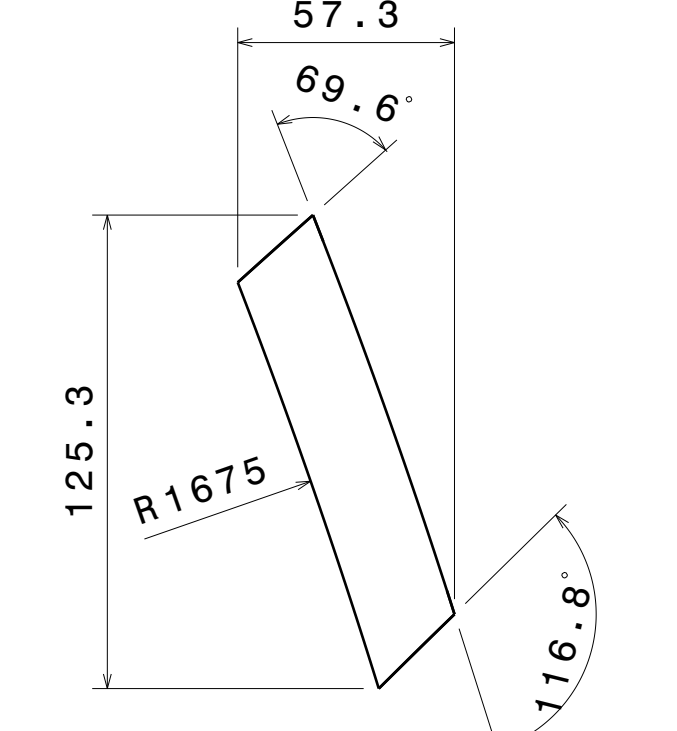

ITEM 34 DETAILS  
Sq\_tube 33.1 Frame 34

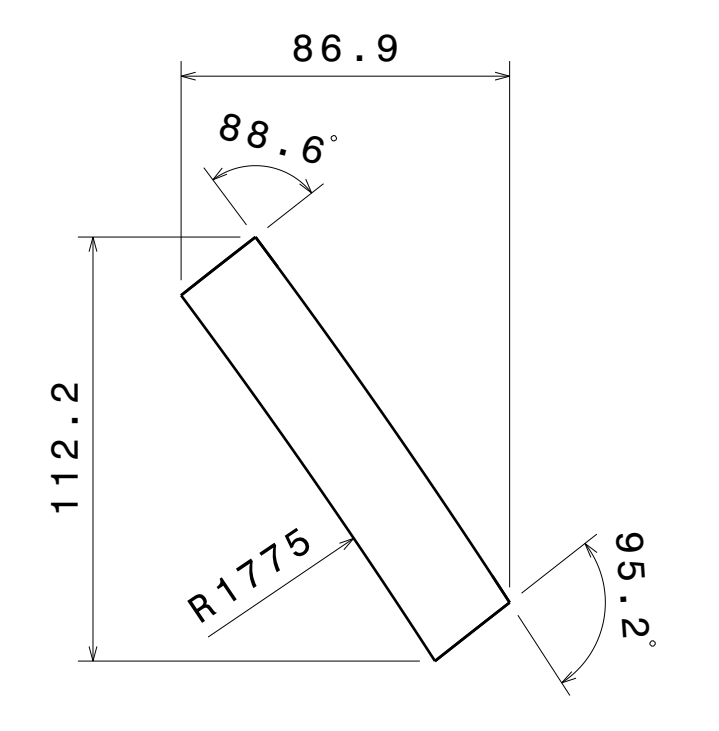

ITEM 35 DETAILS  
Sq\_tube 33.1 Frame 35

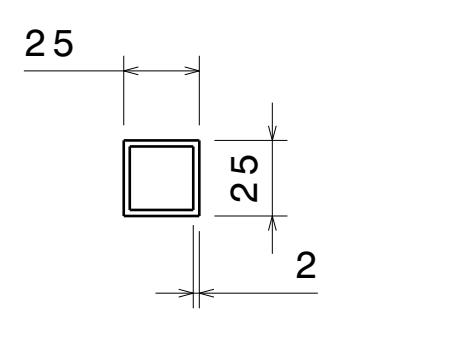

Section Detail of  
ITEM  
23,24,25,26,27,28,2,  
9,30,31,32,33,34,35,  
36,37 & 28  
Scale: 1:2

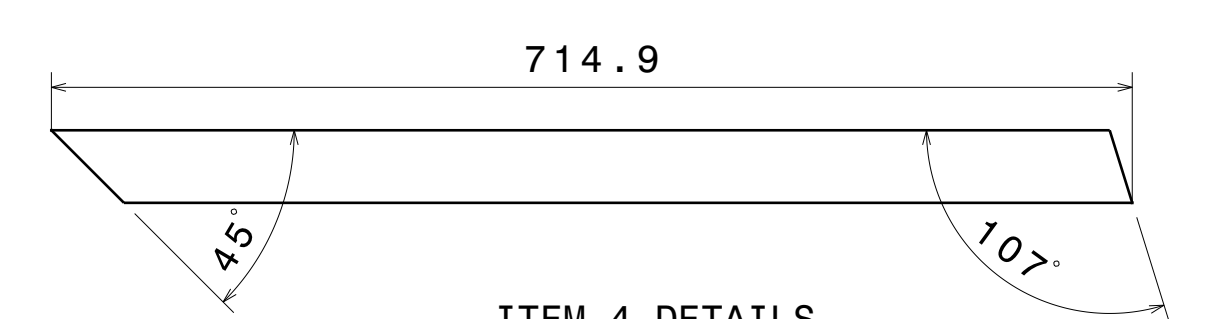

ITEM 4 DETAILS  
rect\_tube 33.1 Frame 4



ITEM 21 DETAILS  
Sq\_tube 33.1 Frame 21

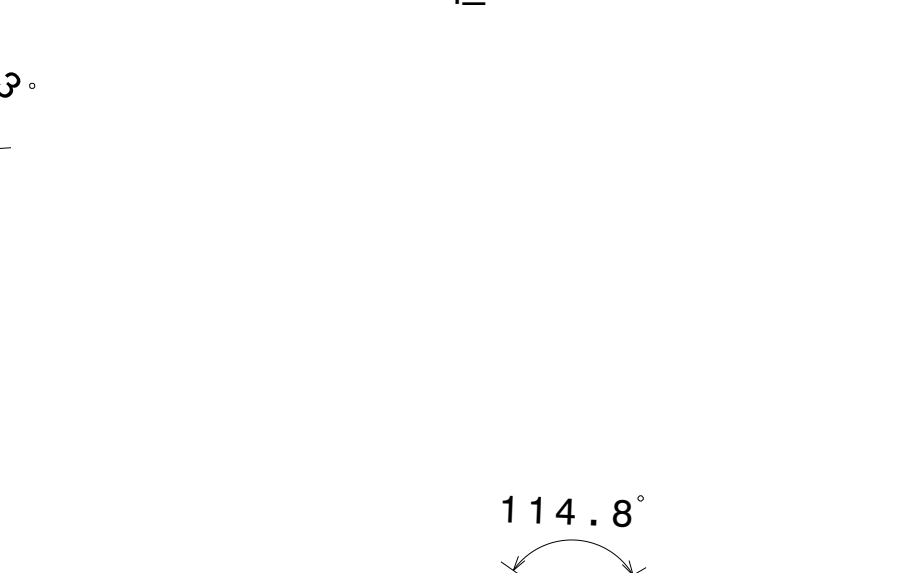

ITEM 31 DETAILS  
Sq\_tube 33.1 Frame 31

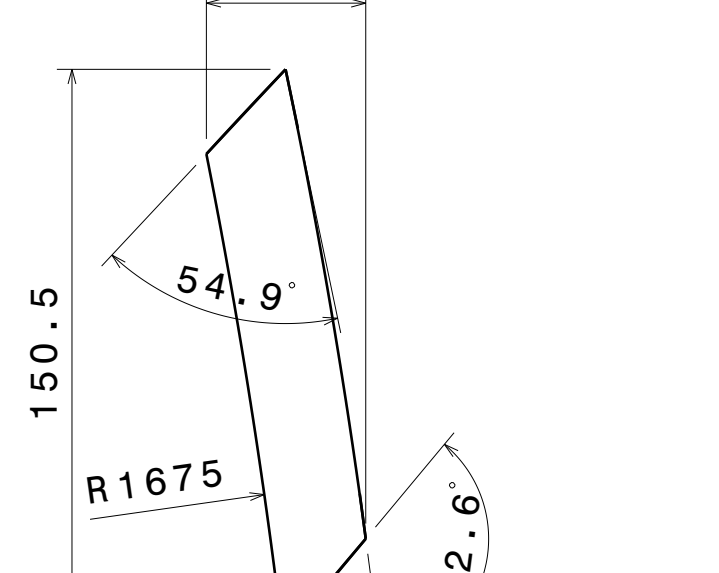

ITEM 32 DETAILS  
Sq\_tube 33.1 Frame 32

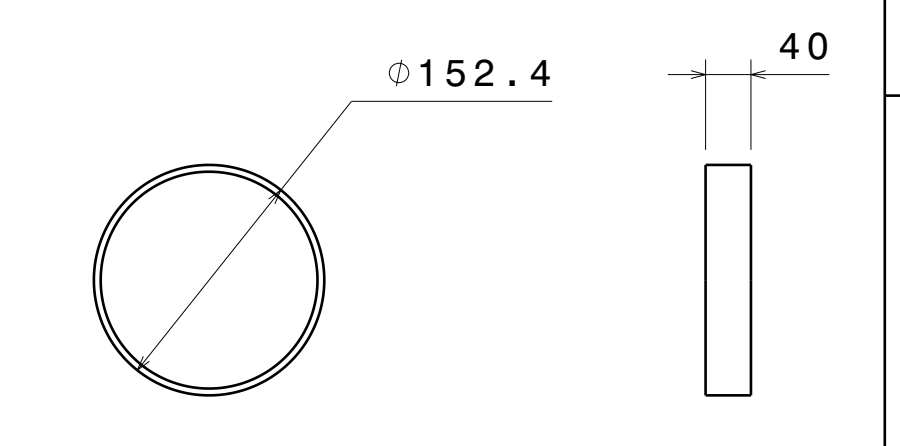

ITEM 5 DETAILS  
round\_tube 33.1 Frame 5

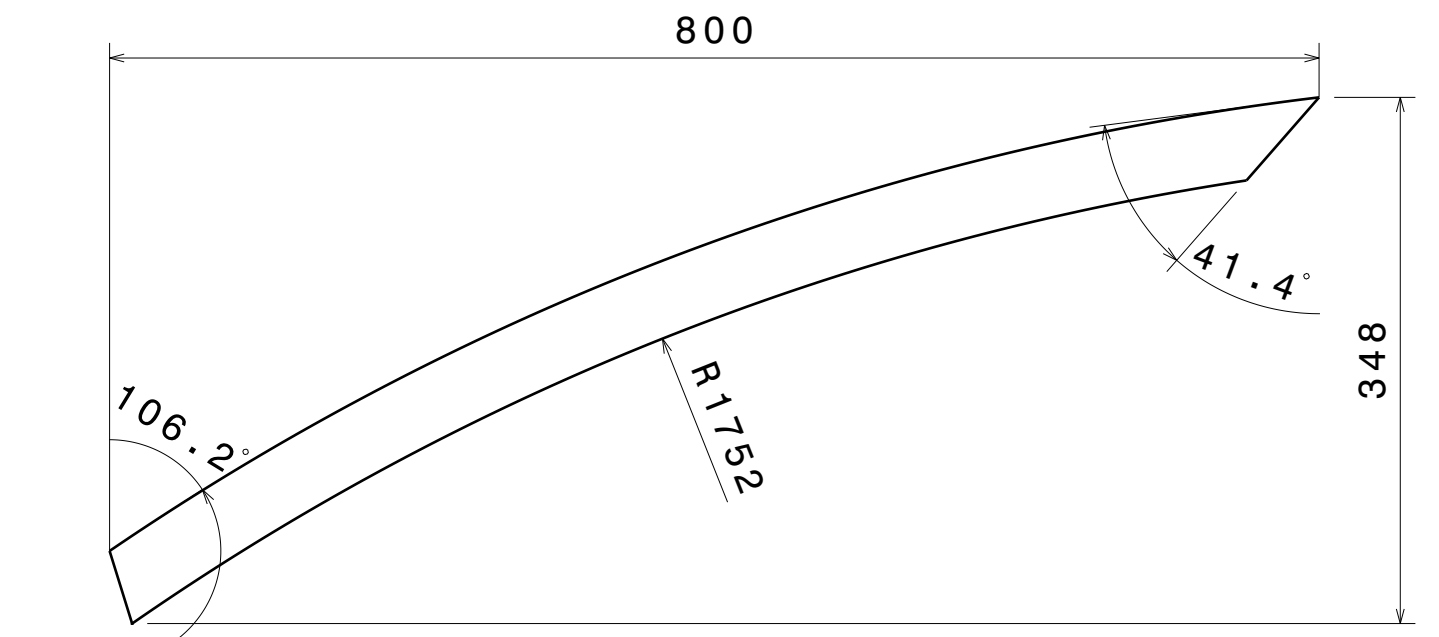

ITEM 3 DETAILS  
rect\_tube 33.1 Frame 3

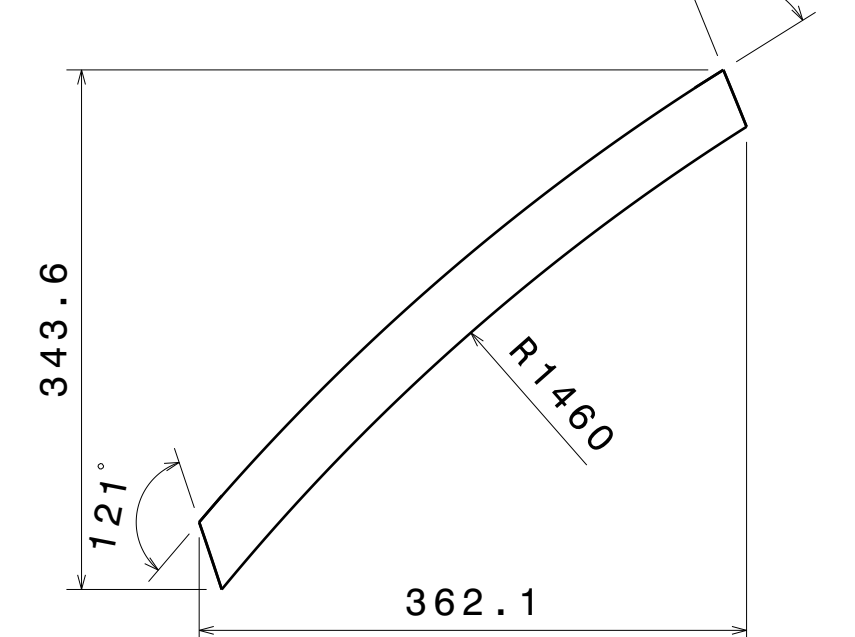

ITEM 11 DETAILS  
Sq\_tube 33.1 Frame 11

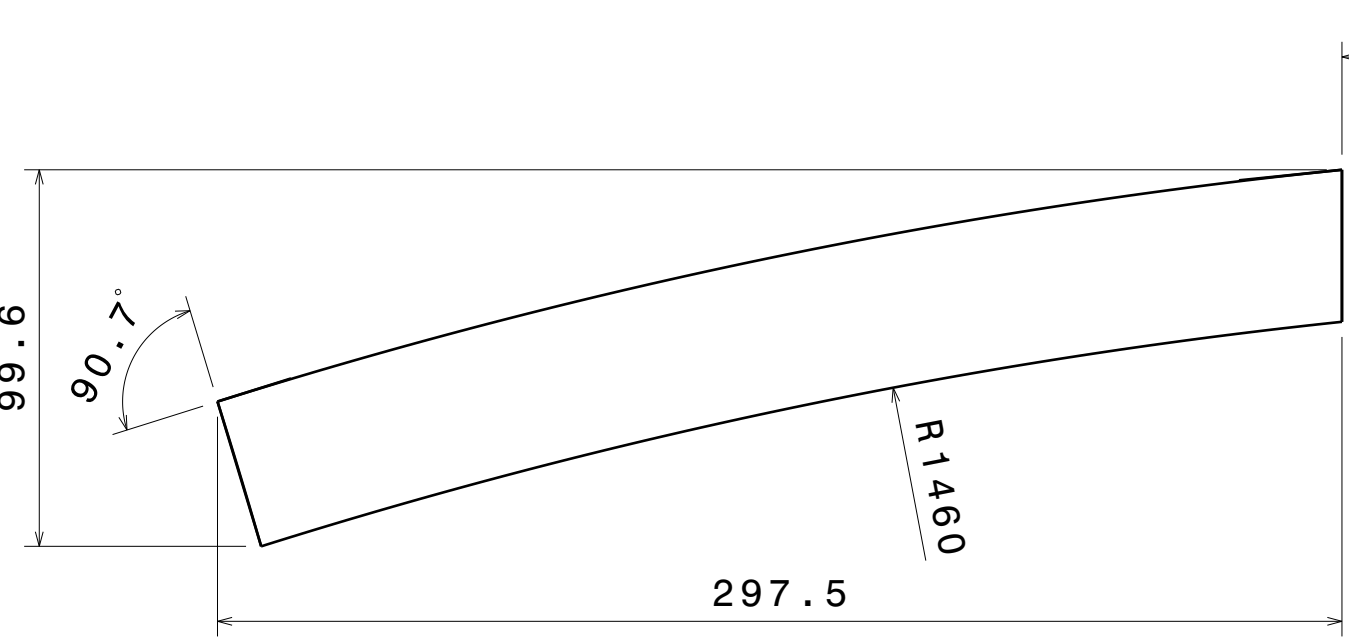

ITEM 20 DETAILS  
Sq\_tube 33.1 Frame 20

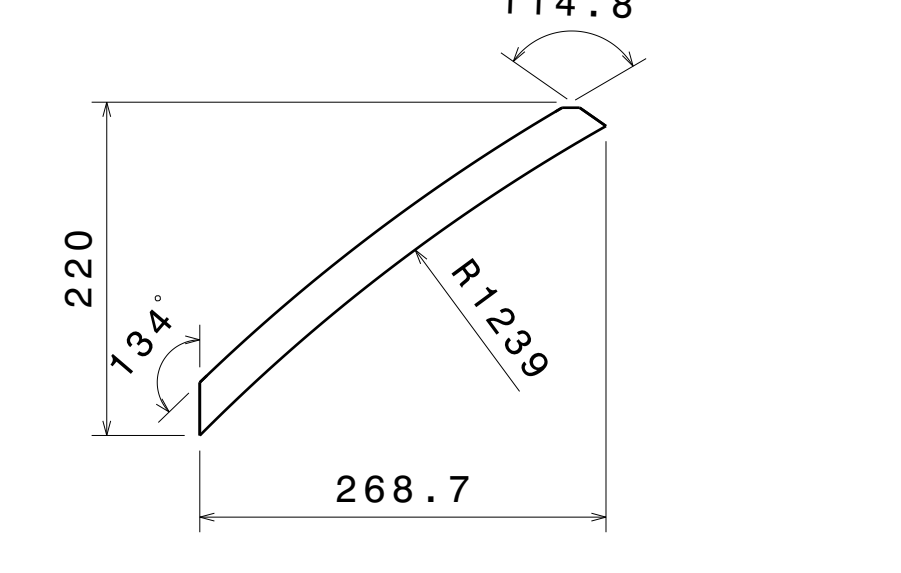

ITEM 30 DETAILS  
Sq\_tube 33.1 Frame 30

UNLESS OTHERWISE SPECIFIED DIMENSION ARE IN MM VIEWS: THIRD ANGLE PROJECTION

This drawing is our property. It can't be reproduced or communicated without our written agreement.

DRAWN BY: SB  
CHECKED BY: P2P Analysis & Solutions  
DESIGNED BY: P2P Analysis & Solutions

DATE: 24MAR2020  
DATE: 24MAR2020  
DATE: 24MAR2020

APL APOLLO TUBES LTD.		DRAWING TITLE	
GATE-33		REV	
SIZE	DRAWING NUMBER	REV	
A0	P2P_GATE_00033	00	
SCALE	NONE	WEIGHT (kg)	XXX
			SHEET 3 OF 5