

REV	DATE	DESCRIPTION
00	22MAR2020	INITIAL REVISION

NOTES:

- (⊥) ALL VERTICAL SUPPORTS ARE PERPENDICULAR.
- FLATNESS OF .5MM IS APPLIED BY DEFAULT.
- ⊥ WELD BEAD OF 2MM RADIUS IS FOLLOWED.
- ▽ SURFACE FINISH MEDIUM TO SMOOTH IS USED.
- ALL TUBES ARE AS PER APL APOLLO STANDARD. CHANGES MAY EFFECT THE LOAD CAPACITY.
- ALL HORIZONTAL AND VERTICAL TUBES ARE PERPENDICULAR TO EACH OTHER WITH ±1 DEG.
- FINE WELDING IS REQUIRED AS PER MENTIONED DETAILS AND FINISHING.
- HIGHER CURRENT WELDING MAY AFFECT THE BRITTLENESS OF MATERIAL WHICH LATER MAY RAISE TO WEAKENING OF STRUCTURE.
- FABRICATORS ARE ALLOWED TO USE FITTINGS/FRAMES/SUPPORTS AS NEEDED AND THE SAME MUST BE COMMUNICATED BACK TO ENGINEERING TEAM.
- LENGTH OF ALL LONGITUDINAL FRAMES ARE FOR REFERENCE ONLY AND SUBJECTED TO CHANGE PER REQUIREMENT.

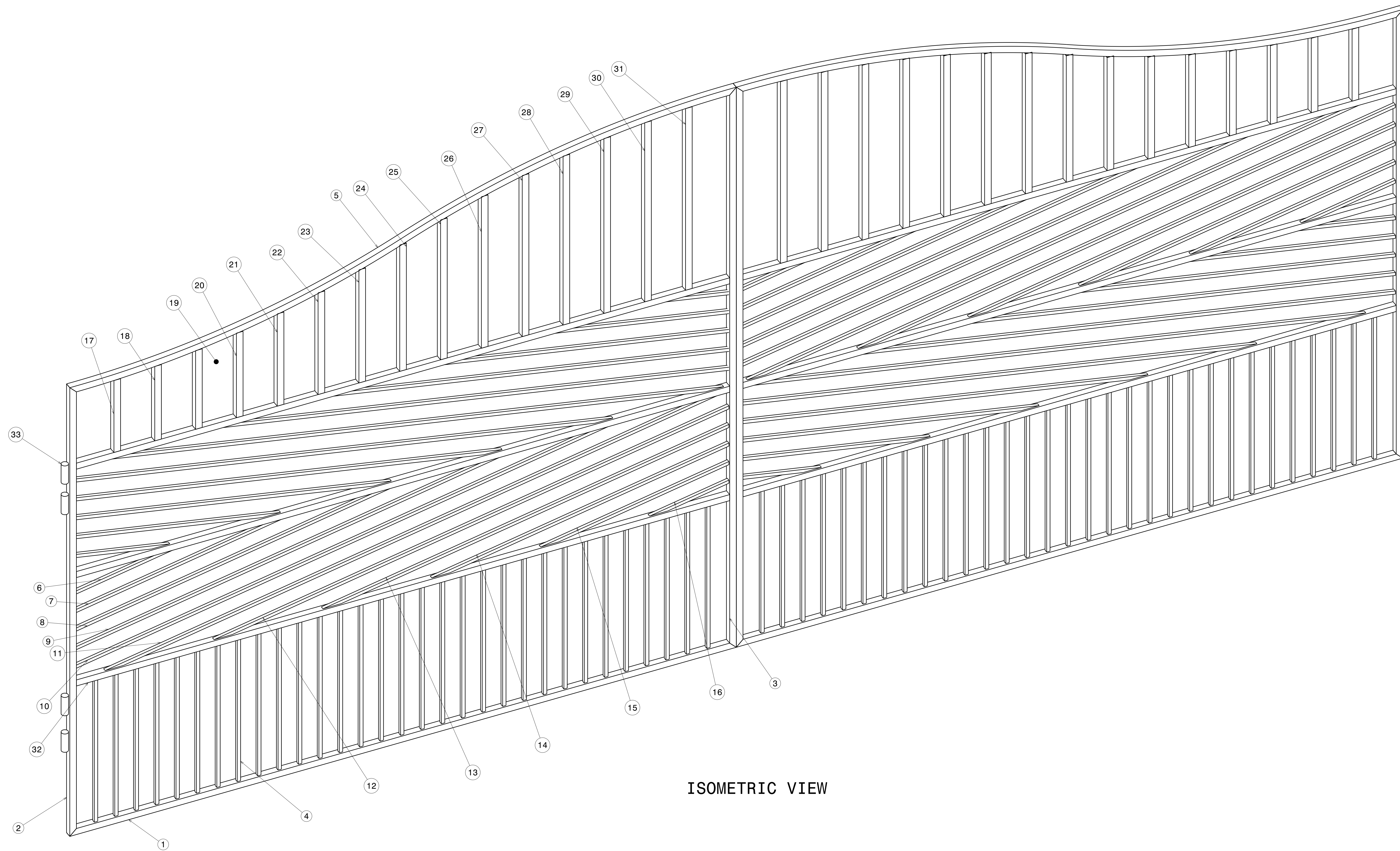

ISOMETRIC VIEW

ITEM NO.	PART NUMBER	DESCRIPTION	AS REQUIRED	QTY.
33	HINGE	AS REQUIRED	AS REQUIRED	
32	Square Tube 32 Frame 31	49.5 X 49.5 X 2.6 X 4877	6	
31	Square Tube 32 Frame 30	49.5 X 49.5 X 2.6 X 1499	4	
30	Square Tube 32 Frame 29	49.5 X 49.5 X 2.6 X 1471	4	
29	Square Tube 32 Frame 28	49.5 X 49.5 X 2.6 X 1436	4	
28	Square Tube 32 Frame 27	49.5 X 49.5 X 2.6 X 1386	4	
27	Square Tube 32 Frame 26	49.5 X 49.5 X 2.6 X 1322	4	
26	Square Tube 32 Frame 25	49.5 X 49.5 X 2.6 X 1243	4	
25	Square Tube 32 Frame 24	49.5 X 49.5 X 2.6 X 1149	4	
24	Square Tube 32 Frame 23	49.5 X 49.5 X 2.6 X 1038	4	
23	Square Tube 32 Frame 22	49.5 X 49.5 X 2.6 X 928	4	
22	Square Tube 32 Frame 21	49.5 X 49.5 X 2.6 X 835	4	
21	Square Tube 32 Frame 20	49.5 X 49.5 X 2.6 X 757	4	
20	Square Tube 32 Frame 19	49.5 X 49.5 X 2.6 X 695	4	
19	Square Tube 32 Frame 18	49.5 X 49.5 X 2.6 X 646	4	
18	Square Tube 32 Frame 17	49.5 X 49.5 X 2.6 X 611	4	
17	Square Tube 32 Frame 16	49.5 X 49.5 X 2.6 X 591	4	
16	Square Tube 32 Frame 15	25 X 25 X 1.6 X 715	4	
15	Square Tube 32 Frame 14	25 X 25 X 1.6 X 1557	4	
14	Square Tube 32 Frame 13	25 X 25 X 1.6 X 2398	4	
13	Square Tube 32 Frame 12	25 X 25 X 1.6 X 3239	4	
12	Square Tube 32 Frame 11	25 X 25 X 1.6 X 4081	4	
11	Square Tube 32 Frame 10	25 X 25 X 1.6 X 4559	4	
10	Square Tube 32 Frame 9	25 X 25 X 1.6 X 3896	4	
9	Square Tube 32 Frame 8	25 X 25 X 1.6 X 3055	4	
8	Square Tube 32 Frame 7	25 X 25 X 1.6 X 2213	4	
7	Square Tube 32 Frame 6	25 X 25 X 1.6 X 1372	4	
6	Square Tube 32 Frame 5	25 X 25 X 1.6 X 531	4	
5	Square Tube 32 Frame 5 CRV	49.5 X 49.5 X 2.6 X SEE DETAILS	2	
4	Square Tube 32 Frame 4	49.5 X 49.5 X 2.6 X 1170	62	
3	Square Tube 32 Frame 3	49.5 X 49.5 X 2.6 X 4597	2	
2	Square Tube 32 Frame 2	49.5 X 49.5 X 2.6 X 3682.5	2	
1	Square Tube 32 Frame 1	49.5 X 49.5 X 2.6 X 4976	2	

This drawing is our property. It can't be reproduced or communicated without our written agreement.

APL APOLLO TUBES LTD.

DRAWING TITLE: **GATE 32**

SCALE: **As Indicated** WEIGHT(kg): **605kg** SHEET **1** OF **5**

UNLESS OTHERWISE SPECIFIED DIMENSION ARE IN MM VIEWS: THIRD ANGLE PROJECTION

DRAWN BY	DATE	CHECKED BY	DATE	DESIGNED BY	DATE
SB	22MAR2020	P2P Analysis & Solutions	22MAR2020	P2P Analysis & Solutions	22MAR2020

SIZE	DRAWING NUMBER	REV
A0	P2P GATE 00032	00

REV	DATE	DESCRIPTION
00	22MAR2020	INITIAL REVISION

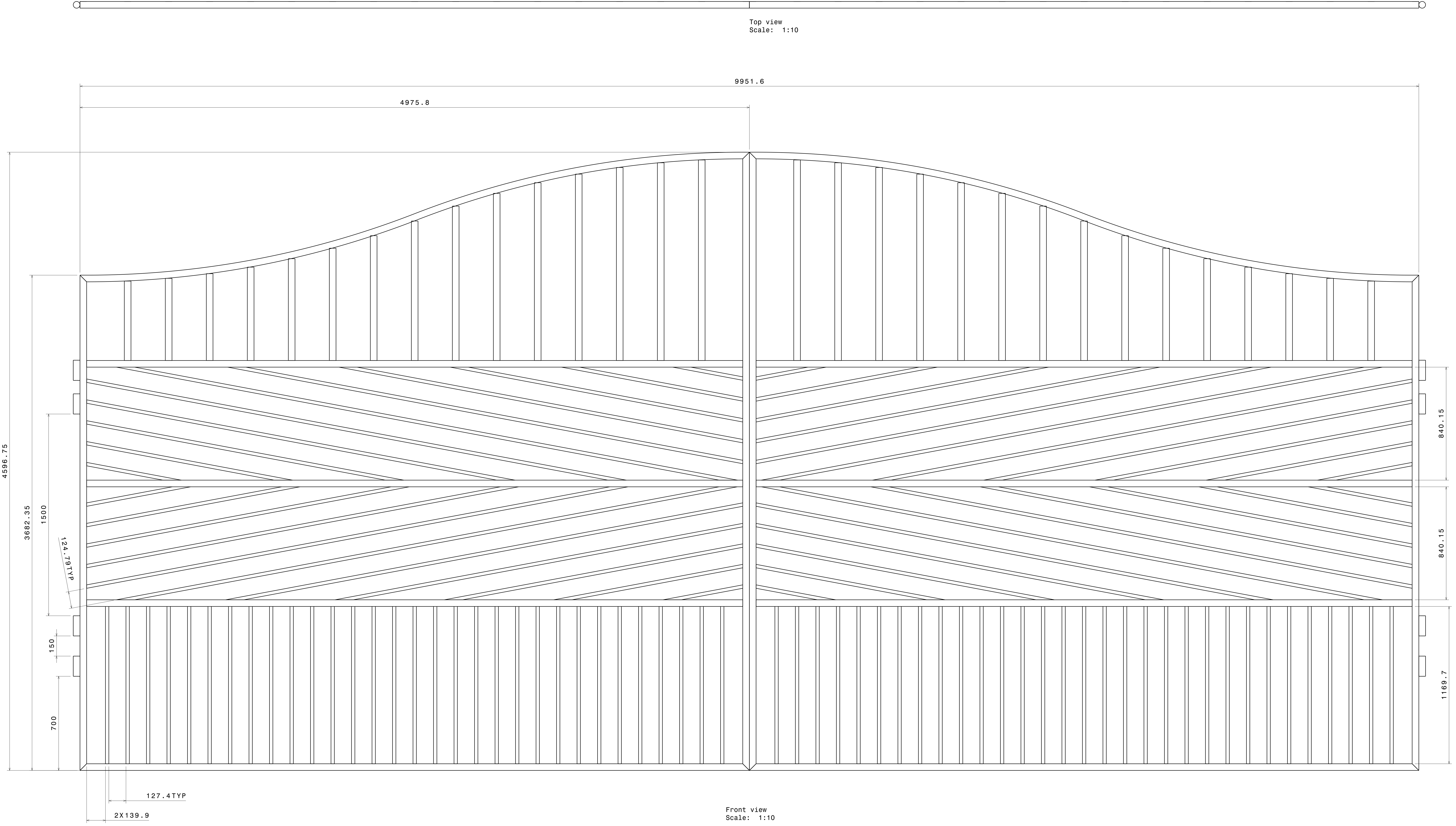

This drawing is our property. It can't be reproduced or communicated without our written agreement.		APL APOLLO TUBES LTD. 	
DRAWN BY SB		DRAWING TITLE GATE 32	
CHECKED BY P2P Analysis & Solutions		SIZE A0	
DESIGNED BY P2P Analysis & Solutions		DRAWING NUMBER P2P_GATE_00032	
DATE 22MAR2020	DATE 22MAR2020	SCALE NONE	REV 00
DATE 22MAR2020	DATE 22MAR2020	WEIGHT (kg) XXX	SHEET 2 OF 5

UNLESS OTHERWISE SPECIFIED DIMENSION ARE IN MM
VIEWS: THIRD ANGLE PROJECTION

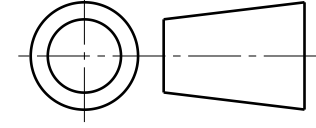

REV	DATE	DESCRIPTION
00	22MAR2020	INITIAL REVISION



ITEM 5
49.5SQX2.6 THK

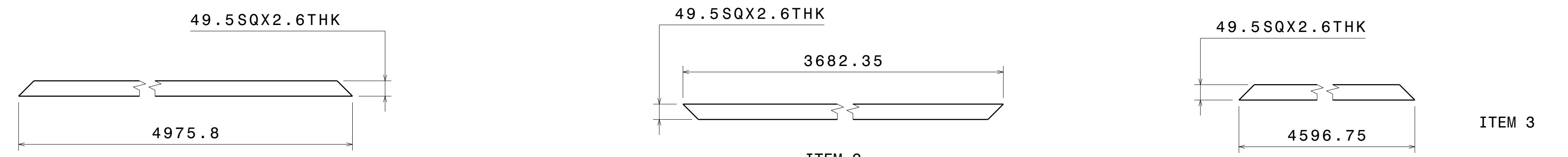

ITEM 1

ITEM 2

ITEM 3

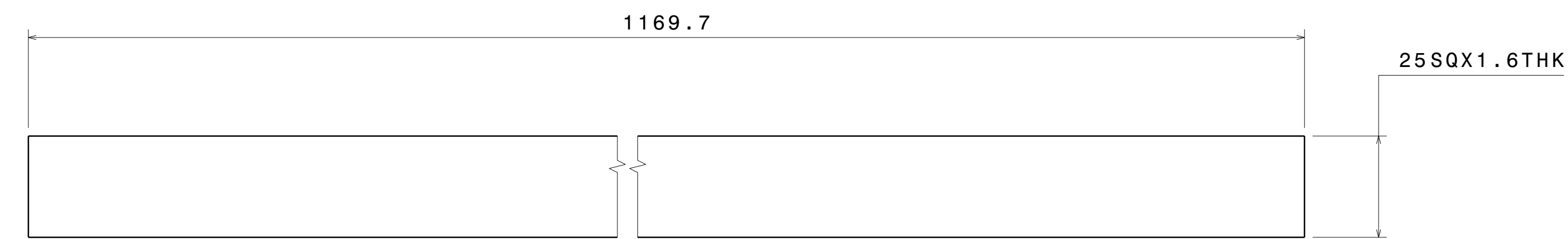

ITEM 4

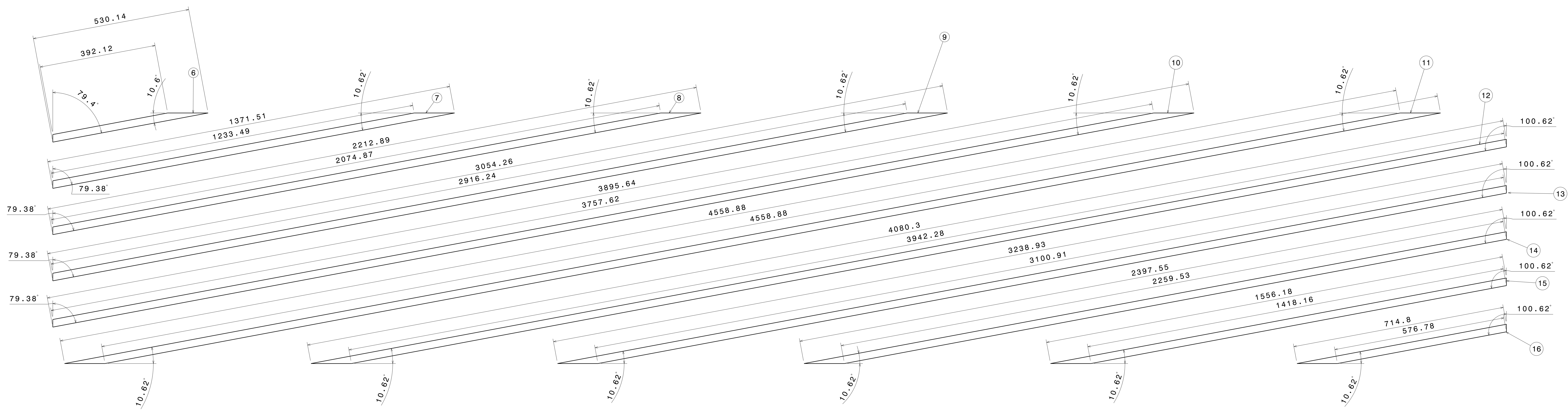

ITEM 6 TO ITEM 16
ARE OF SAME SQUARE
CROSS SECTION:
49.5 SQ X 2.6 THK

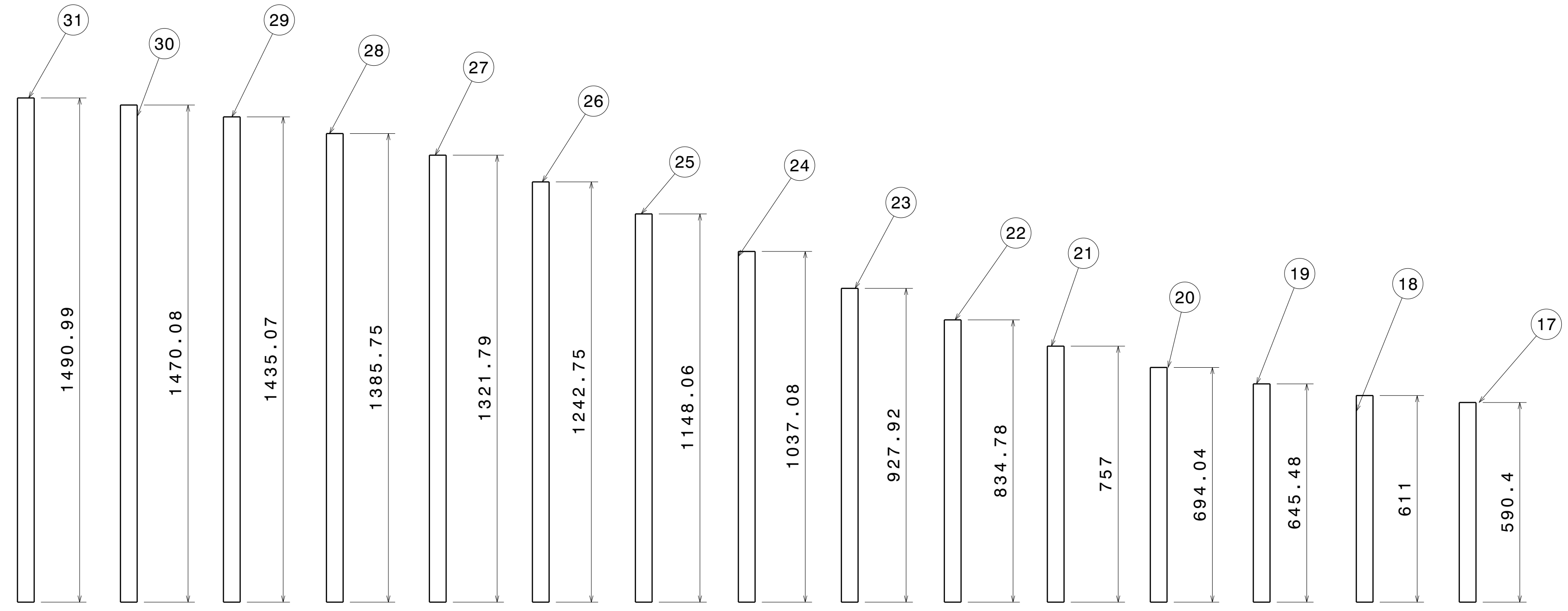

ITEM 17 TO ITEM 31
ARE OF SAME SQUARE
CROSS SECTION:
49.5 SQ X 2.6 THK

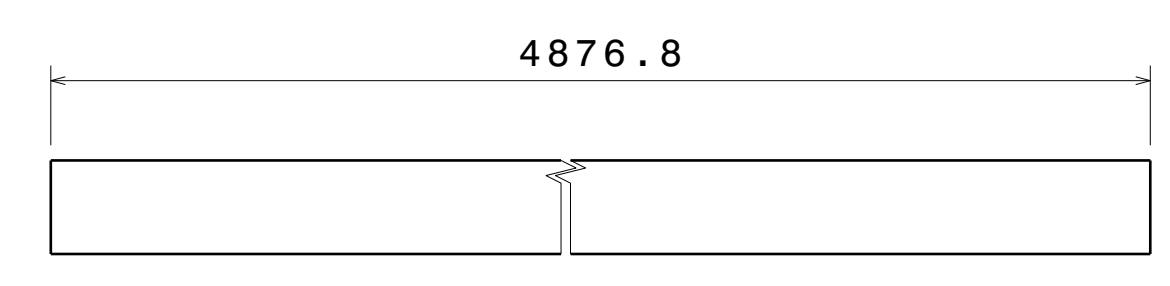

ITEM 32

This drawing is our property. It can't be reproduced or communicated without our written agreement.

APL APOLLO TUBES LTD.

DRAWN BY		DATE		DRAWING TITLE	
SB		22MAR2020		GATE 32	
CHECKED BY		DATE		SIZE	DRAWING NUMBER
P2P Analysis & Solutions		22MAR2020		A0	P2P_GATE_00032
DESIGNED BY		DATE		SCALE	WEIGHT (kg)
P2P Analysis & Solutions		22MAR2020		NONE	XXX
				SHEET 3 OF 5	

UNLESS OTHERWISE SPECIFIED
DIMENSION ARE IN MM
VIEWS:
THIRD ANGLE PROJECTION