

REV/DATE	DESCRIPTION
A / 2/25/2020	INITIAL REVISION

- NOTES:
- (⊥) ALL VERTICAL SUPPORTS ARE PERPENDICULAR.
 - FLATNESS OF .5MM IS APPLIED BY DEFAULT.
 - ⊘ WELD BEAD OF 2MM RADIUS IS FOLLOWED.
 - SURFACE FINISH MEDIUM TO SMOOTH IS USED.
 - ALL TUBES ARE AS PER APL APOLLO STANDARD. CHANGES MAY EFFECT THE LOAD CAPACITY.
 - DUAL DIMENSIONS USED WITH BOTH METRIC AND INCH SYSTEM.
 - ALL HORIZONTAL AND VERTICAL TUBES ARE PERPENDICULAR TO EACH OTHER WITH ±1 DEG.
 - FINE WELDING IS REQUIRED AS PER MENTIONED DETAILS AND FINISHING.
 - HIGHER CURRENT WELDING MAY AFFECT THE BRITTLENESS OF MATERIAL WHICH LATER MAY RAISE TO WEAKENING OF STRUCTURE.

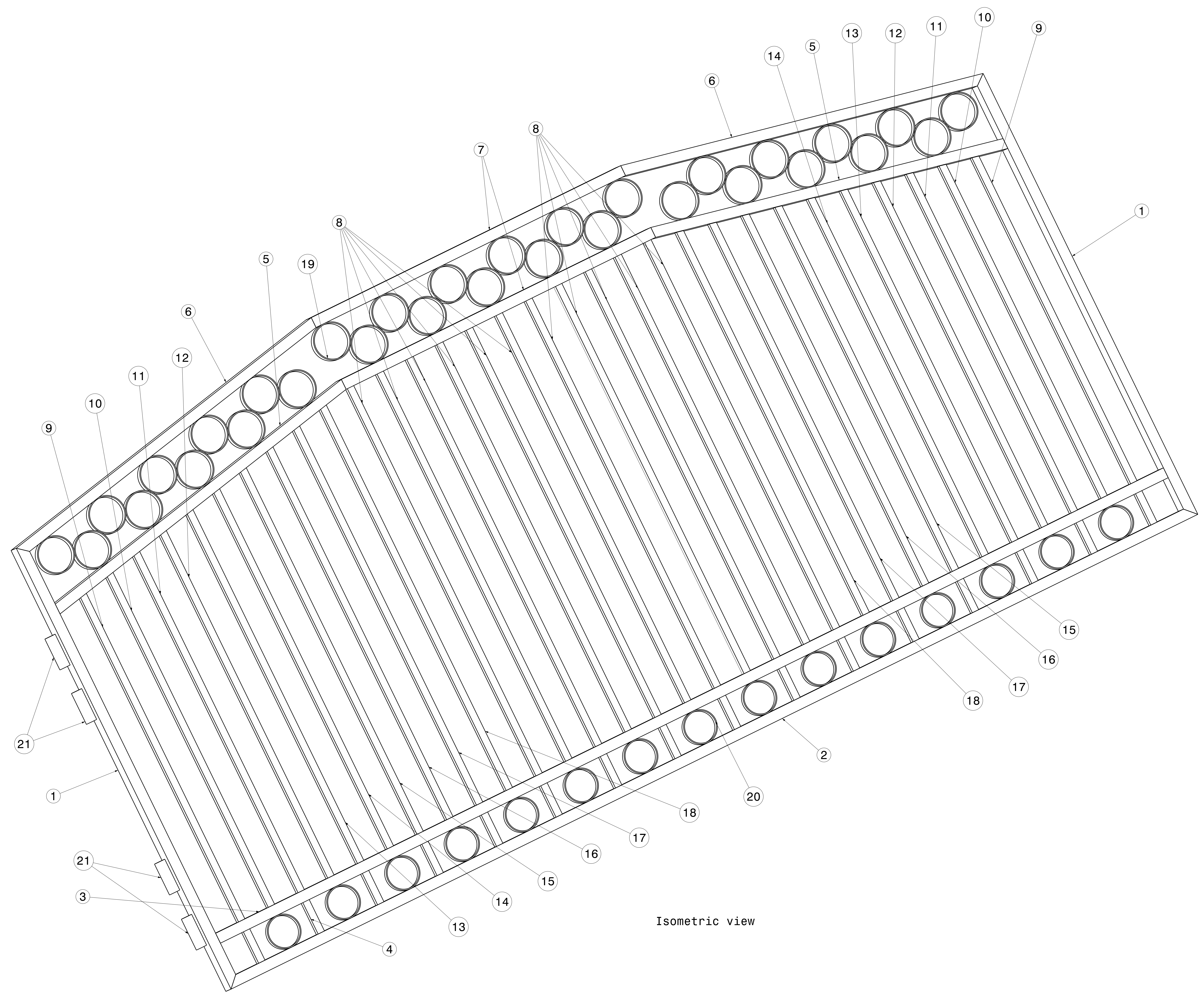

ITEM NO.	PART NUMBER	DESCRIPTION	QTY.	
21		Hinge	4	
20		Round tube 30.1 Frame 2	152.4 X 4.5 X 30	15
19		Round tube 30.1 Frame 1	168.3 X 4.5 X 40	31
18		Square tube 30.1 Frame 12	32 X 32 X 2 X 1863.2	2
17		Square tube 30.1 Frame 11	32 X 32 X 2 X 1832.5	2
16		Square tube 30.1 Frame 10	32 X 32 X 2 X 1801.7	2
15		Square tube 30.1 Frame 9	32 X 32 X 2 X 1770.9	2
14		Square tube 30.1 Frame 8	32 X 32 X 2 X 1740.2	2
13		Square tube 30.1 Frame 7	32 X 32 X 2 X 1709.4	2
12		Square tube 30.1 Frame 6	32 X 32 X 2 X 1678.6	2
11		Square tube 30.1 Frame 5	32 X 32 X 2 X 1647.9	2
10		Square tube 30.1 Frame 4	32 X 32 X 2 X 1617.1	2
9		Square tube 30.1 Frame 3	32 X 32 X 2 X 1586.3	2
8		Square tube 30.1 Frame 2	32 X 32 X 2 X 1555.5	2
7		Rectangle Tube 30.1 Frame 6	96 X 48 X 3.2 X 1561	2
6		Rectangle Tube 30.1 Frame 5	96 X 48 X 3.2 X 1651.75	2
5		Rectangle Tube 30.1 Frame 4	96 X 48 X 3.2 X 1653	2
4		Square tube 30.1 Frame 1	32 X 32 X 2 X 153	16
3		Rectangle Tube 30.1 Frame 3	96 X 48 X 3.2 X 4780.8	1
2		Rectangle Tube 30.1 Frame 2	96 X 48 X 3.2 X 4876.8	1
1		Rectangle Tube 30.1 Frame 1	96 X 48 X 3.2 X 2145.6	2

This drawing is our property. It can't be reproduced or communicated without our written agreement.

APL APOLLO TUBES LTD.

DRAWING TITLE: **GATE 30**

DRAWN BY: SB	DATE: 2/25/2020	SIZE: A0	DRAWING NUMBER: P2P APL 00030	REV: 00
CHECKED BY: P2P Analysis & Solutions	DATE: 2/25/2020	SCALE: NONE	WEIGHT (kg): 430	SHEET: 1
DESIGNED BY: P2P Analysis & Solutions	DATE: 2/25/2020			

UNLESS OTHERWISE SPECIFIED DIMENSION ARE IN MM
 VIEWS: THIRD ANGLE PROJECTION

REV	DATE	DESCRIPTION
00	2/25/2020	INITIAL REVISION

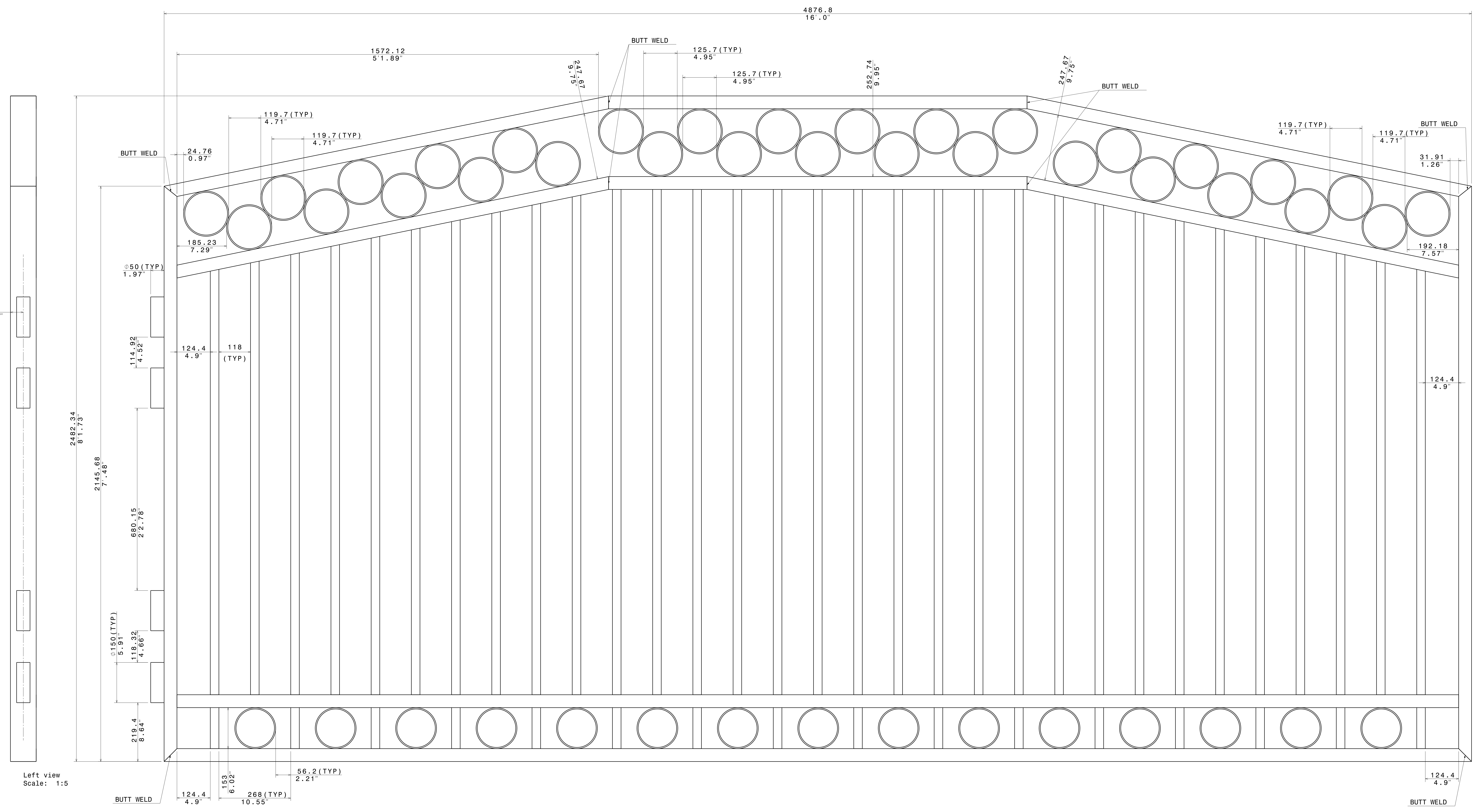

Left view
Scale: 1:5

UNLESS OTHERWISE SPECIFIED DIMENSION ARE IN MM
VIEWS: THIRD ANGLE PROJECTION

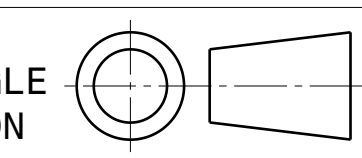

This drawing is our property. It can't be reproduced or communicated without our written agreement.		APL APOLLO TUBES LTD. 	
DRAWN BY SB		DRAWING TITLE GATE 30	
CHECKED BY P2P Analysis & Solutions	DATE 2/25/2020	SIZE A0	DRAWING NUMBER P2P APL 00030
DESIGNED BY P2P Analysis & Solutions	DATE 2/25/2020	SCALE NONE	WEIGHT (kg) XXX
		SHEET 2	

REV	DATE	DESCRIPTION
00	2/25/2020	INITIAL REVISION

4780.8

ITEM 3 DETAILS
Rect Tube 30.1 Frame 3

4876.8

ITEM 2 DETAILS
Rect Tube 30.1 Frame 2

2145.68

ITEM 1 DETAILS
Rect Tube 30.1 Frame 1

1652.98

ITEM 5 DETAILS
Rect Tube 30.1 Frame 4

1691.75

ITEM 6 DETAILS
Rect Tube 30.1 Frame 5

1561

ITEM 7 DETAILS
Rect Tube 30.1 Frame 6

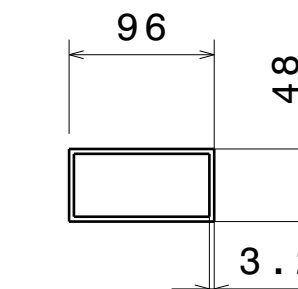

Section Detail of ITEM 1,2,3,5,6 & 7
Scale: 1:5

Ø168.3

ITEM 19 DETAILS
round_tube 30.1 Frame 1

Ø152.4

ITEM 20 DETAILS
round_tube 30.1 Frame 2

1884.6

ITEM 8 DETAILS
Sq tube 30.1 Frame 2

1586.36

ITEM 9 DETAILS
Sq tube 30.1 Frame 3

1617.13

ITEM 10 DETAILS
Sq tube 30.1 Frame 4

1647.9

ITEM 11 DETAILS
Sq tube 30.1 Frame 5

1678.67

ITEM 12 DETAILS
Sq tube 30.1 Frame 6

1709.43

ITEM 13 DETAILS
Sq tube 30.1 Frame 7

1740.2

ITEM 14 DETAILS
Sq tube 30.1 Frame 8

1770.97

ITEM 15 DETAILS
Sq tube 30.1 Frame 9

1801.73

ITEM 16 DETAILS
Sq tube 30.1 Frame 10

1832.5

ITEM 17 DETAILS
Sq tube 30.1 Frame 11

1863.27

ITEM 18 DETAILS
Sq tube 30.1 Frame 12

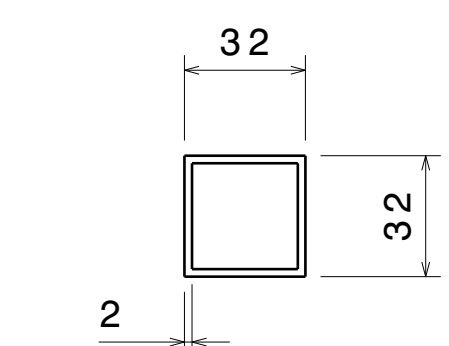

Section Detail of ITEM 4,8,9,10,11,12,13,14,15,16,17 & 18
Scale: 1:2

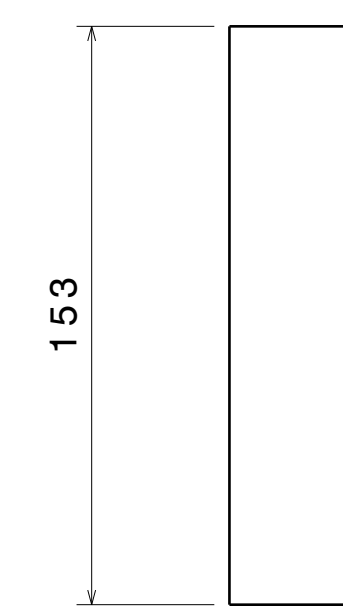

ITEM 4 DETAILS
Sq tube 30.1 Frame 1

This drawing is our property. It can't be reproduced or communicated without our written agreement.

APL APOLLO TUBES LTD.

DRAWN BY	DATE
SB	2/25/2020
CHECKED BY	DATE
P2P Analysis & Solutions	2/25/2020
DESIGNED BY	DATE
P2P Analysis & Solutions	2/25/2020

DRAWING TITLE		GATE 30	
SIZE	DRAWING NUMBER	REV	
A0	P2P APL_00030	00	
SCALE	NONE	WEIGHT (kg)	XXX
			SHEET 3

UNLESS OTHERWISE SPECIFIED DIMENSION ARE IN MM VIEWS: THIRD ANGLE PROJECTION