

REV/DATE	DESCRIPTION
00 / 1/28/2020	INITIAL REVISION

- NOTES:
- (⊥) ALL VERTICAL SUPPORTS ARE PERPENDICULAR.
 - FLATNESS OF .5MM IS APPLIED BY DEFAULT.
 - ⊥ WELD BEAD OF 2MM RADIUS IS FOLLOWED.
 - ▽ SURFACE FINISH MEDIUM TO SMOOTH IS USED.
 - ALL TUBES ARE AS PER APL APOLLO STANDARD. CHANGES MAY EFFECT THE LOAD CAPACITY.
 - DUAL DIMENSIONS USED WITH BOTH METRIC AND INCH SYSTEM IN SOME PLACES.
 - ALL HORIZONTAL AND VERTICAL TUBES ARE PERPENDICULAR TO EACH OTHER WITH ±1 DEG.
 - FINE WELDING IS REQUIRED AS PER MENTIONED DETAILS AND FINISHING.
 - HIGHER CURRENT WELDING MAY AFFECT THE BRITTLNESS OF MATERIAL WHICH LATER MAY RAISE TO WEAKENING OF STRUCTURE.

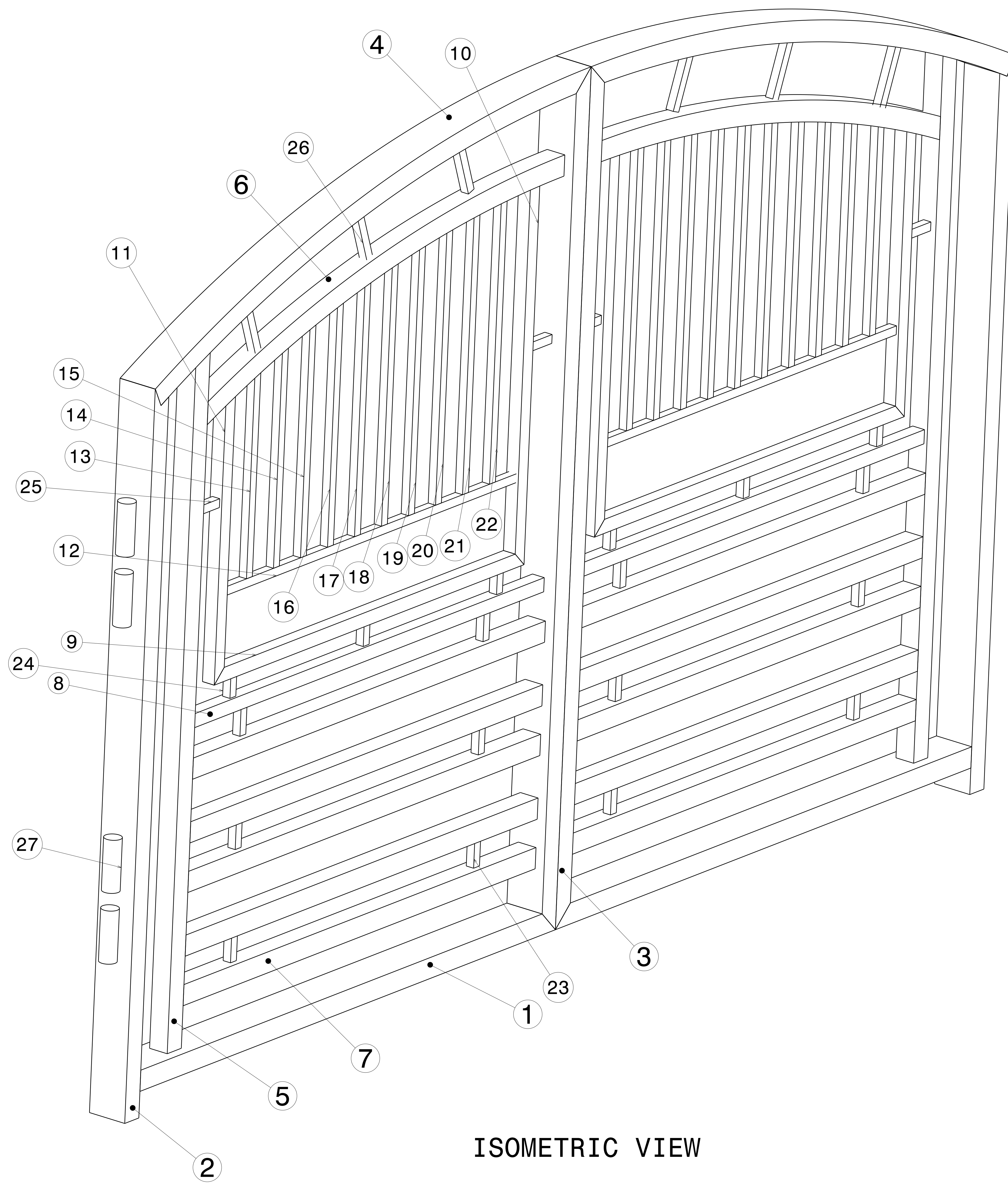

ITEM NO.	PART NUMBER	DESCRIPTION	QTY.
27		HINGE	8
26	SQ TUBE 25 FRAME 26	25 X 25 X 1.6 X 172	6
25	SQ TUBE 25 FRAME 25	25 X 25 X 1.6 X 90	4
24	SQ TUBE 25 FRAME 24	25 X 25 X 1.6 X 60	6
23	SQ TUBE 25 FRAME 23	25 X 25 X 1.6 X 80	12
22	SQ TUBE 25 FRAME 22	25 X 25 X 1.6 X 807	2
21	SQ TUBE 25 FRAME 21	25 X 25 X 1.6 X 798	2
20	SQ TUBE 25 FRAME 20	25 X 25 X 1.6 X 786	2
19	SQ TUBE 25 FRAME 19	25 X 25 X 1.6 X 770	2
18	SQ TUBE 25 FRAME 18	25 X 25 X 1.6 X 751	2
17	SQ TUBE 25 FRAME 17	25 X 25 X 1.6 X 727	2
16	SQ TUBE 25 FRAME 16	25 X 25 X 1.6 X 700	2
15	SQ TUBE 25 FRAME 15	25 X 25 X 1.6 X 669	2
14	SQ TUBE 25 FRAME 14	25 X 25 X 1.6 X 634	2
13	SQ TUBE 25 FRAME 13	25 X 25 X 1.6 X 595	2
12	SQ TUBE 25 FRAME 12	25 X 25 X 1.6 X 1239	2
11	SQ TUBE 25 FRAME 11	40 X 40 X 2.6 X 816	2
10	SQ TUBE 25 FRAME 10	40 X 40 X 2.6 X 1076.4	2
9	SQ TUBE 25 FRAME 9	40 X 40 X 2.6 X 1318.8	2
8	SQ TUBE 25 FRAME 8	40 X 40 X 2.6 X 1498.8	2
7	SQ TUBE 25 FRAME 7	60 X 60 X 2.6 X 1498.8	10
6	SQ TUBE 25 CURVED FRAME 6	60 X 40 X 2.6	2
5	SQ TUBE 25 FRAME 5	60 X 60 X 2.6 X 1999.96	2
4	RECT TUBE 25 CURVED FRAME 1	120 X 60 X 3.2	2
3	RECT TUBE 25 FRAME 3	120 X 60 X 3.2 X 2438.4	2
2	RECT TUBE 25 FRAME 2	120 X 60 X 3.2 X 2074.5	2
1	RECT TUBE 25 FRAME 1	120 X 60 X 3.2 X 1768.8	2

UNLESS OTHERWISE SPECIFIED DIMENSION ARE IN MM VIEWS: THIRD ANGLE PROJECTION

This drawing is our property. It can't be reproduced or communicated without our written agreement.

APL APOLLO TUBES LTD.

DRAWING TITLE
GATE 25

DRAWN BY SB	DATE 1/28/2020	SIZE A0	DRAWING NUMBER P2P APL 00025	REV 00
CHECKED BY P2P Analysis & Solutions	DATE 1/28/2020	SCALE NONE	WEIGHT (kg) 315	SHEET 1
DESIGNED BY P2P Analysis & Solutions	DATE 1/28/2020			

REV	DATE	DESCRIPTION
00	1/28/2020	INITIAL REVISION

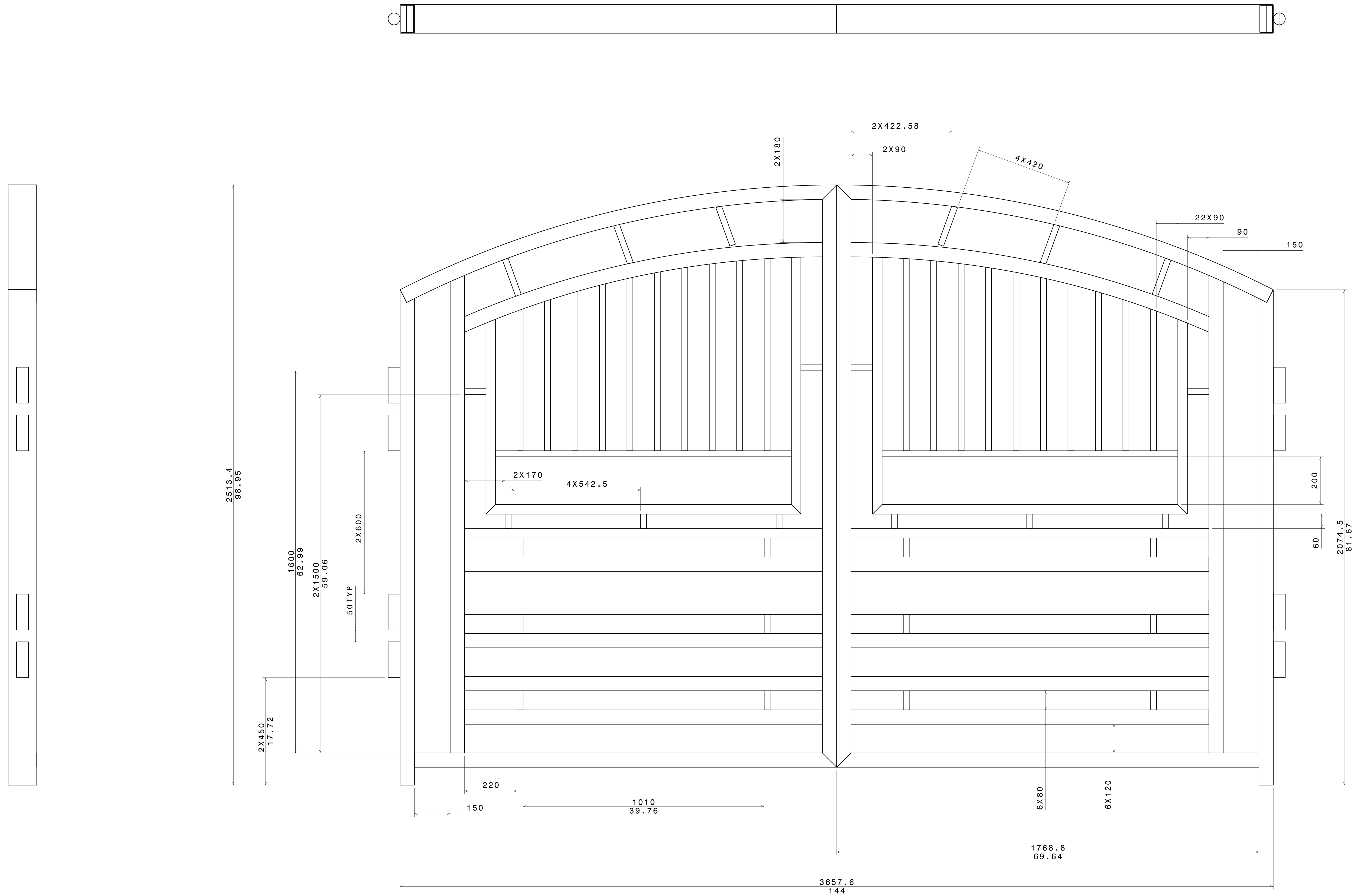

Front view
Scale: 3:20

UNLESS OTHERWISE SPECIFIED DIMENSION ARE IN MM
VIEWS: THIRD ANGLE PROJECTION

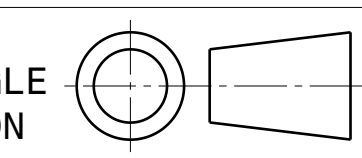

This drawing is our property. It can't be reproduced or communicated without our written agreement.

DRAWN BY	DATE
SB	1/28/2020
CHECKED BY	DATE
P2P Analysis & Solutions	1/28/2020
DESIGNED BY	DATE
P2P Analysis & Solutions	1/28/2020

APL APOLLO TUBES LTD. 	
DRAWING TITLE	
GATE 25	
SIZE	DRAWING NUMBER
A0	P2P APL_00025
SCALE	WEIGHT (kg)
NONE	XXX
SHEET	2

REV	DATE	DESCRIPTION
00	1/28/2020	INITIAL REVISION

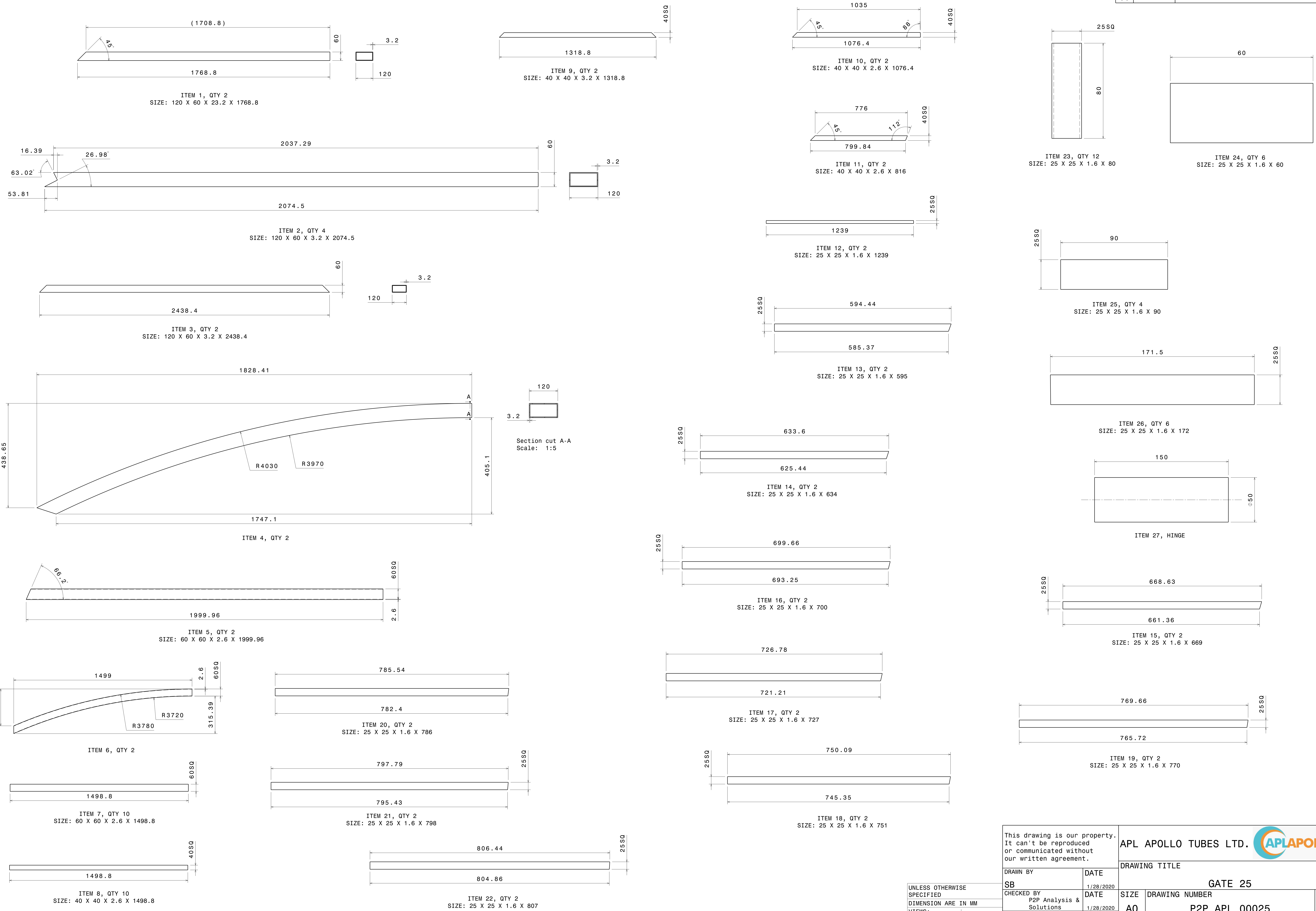

This drawing is our property. It can't be reproduced or communicated without our written agreement.

APL APOLLO TUBES LTD.

DRAWING TITLE: **GATE 25**

DRAWN BY: SB	DATE: 1/28/2020	CHECKED BY: P2P Analysis & Solutions	DATE: 1/28/2020	DESIGNED BY: P2P Analysis & Solutions	DATE: 1/28/2020
--------------	-----------------	--------------------------------------	-----------------	---------------------------------------	-----------------

SIZE: A0	DRAWING NUMBER: P2P APL 00025	REV: 00
SCALE: NONE	WEIGHT (kg): XXX	SHEET: 3

UNLESS OTHERWISE SPECIFIED DIMENSION ARE IN MM VIEWS: THIRD ANGLE PROJECTION