

1

2

3

4

5

6

A

A

B

B

C

C

D

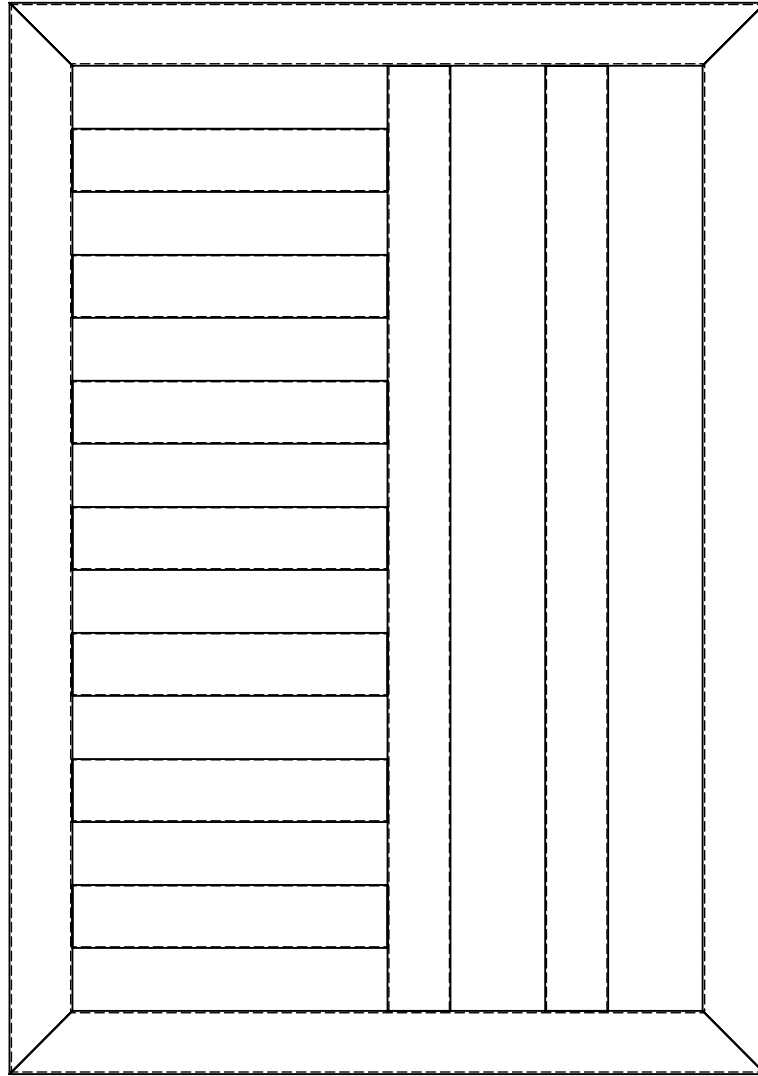

DO NOT SCALE DRAWING

REVISION

TITLE:

	NAME	SIGNATURE	DATE
DRAWN			
CHK'D			
APPVD			

DWG NO.

GATE 1

SCALE:1:50

SHEET 1 OF 3

A4

1

2

3

A

B

C

D

A

B

C

D

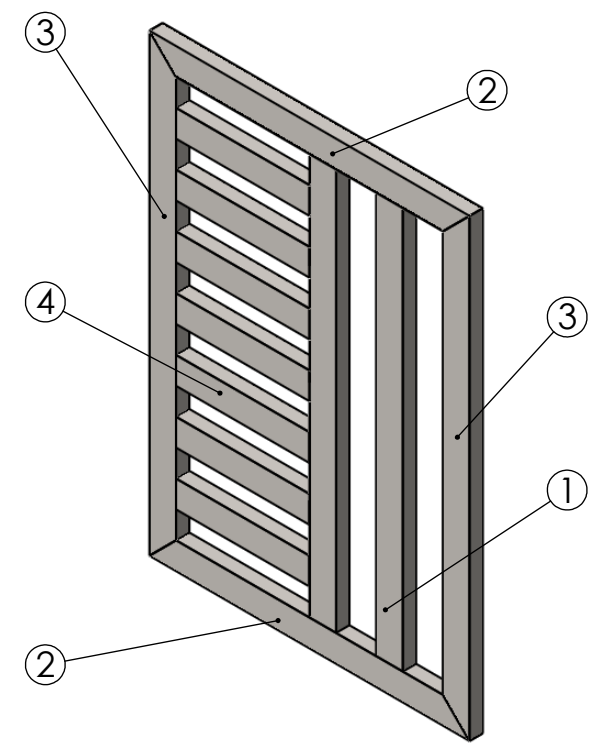
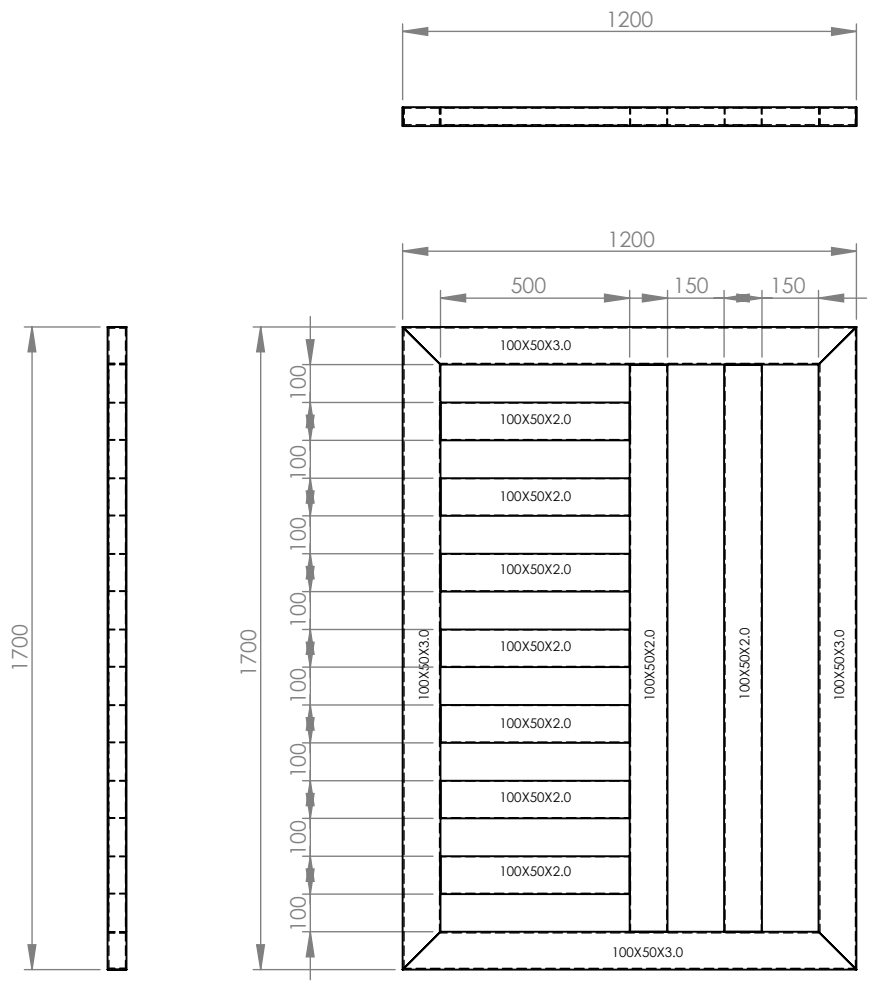

NOTE :-

- ALL VERTICAL AND HORIZONTAL SUPPORTS ARE PERFECTLY 90°.
- ∇ SURFACE FINISH, MEDIUM TO SMOOTH IS USED.
- ALL TUBES ARE AS PER APL APOLLO STANDARD.
- FINE WELDING IS REQUIRED AS PER MENTION DETAILS AND FINISHING.
- JOINTS ARE WELD TOGETHER BY THE HIGH ACCURACY MIG WELDING.
- ALL DIMENSIONS ARE IN MM.
- HIGHER CURRENT WELDING MAY EFFECT THE BRITTLENESS OF MATERIAL WHICH MAY RAISE TO WEAKENING OF STRUCTURE.

ITEM NO.	PART NUMBER	DESCRIPTION	QTY.	LENGTH
1	100X50X2.0X1500	RHS	2	3000
2	100X50X3.0X1200	RHS	2	2400
3	100X50X3.0X1700	RHS	2	3400
4	100X50X2.0X500	RHS	7	3500



DO NOT SCALE DRAWING

REVISION

	NAME	SIGNATURE	DATE	
DRAWN				DWG NO. GATE 1
CHK'D				
APPVD				

SCALE:1:50

SHEET 2 OF 3

A4

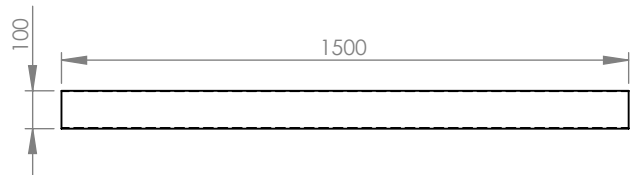

ITEM 1
RHS 100X50X2.0X1500

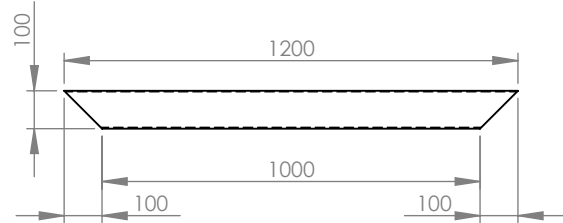

ITEM 2
RHS 100X50X3.0X1200

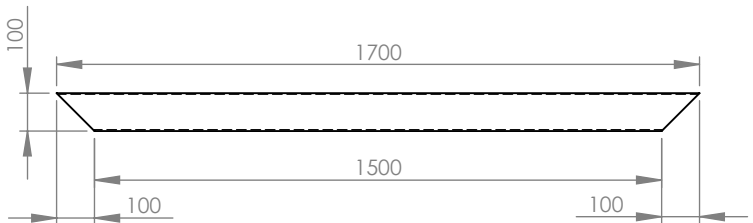

ITEM 3
RHS 100X50X3.0X1700

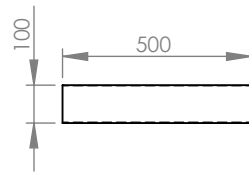

ITEM 4
RHS 100X50X2.0X500



DO NOT SCALE DRAWING			REVISION
TITLE: PART DRAWINGS			
DWG NO.			GATE 1
SCALE:1:50			SHEET 3 OF 3

	NAME	SIGNATURE	DATE
DRAWN			
CHK'D			
APPVD			

1 2 3 4 5 6

A

A

B

B

C

C

D

1 2 3

A4